

# **RSi SG Series**

## **Sensorless Vector Variable Frequency Drive**

**7.5 to 40HP - 230V**

**7.5 to 700HP - 460V**

**7.5 to 150HP - 600V**

### **Instruction Manual**



890046-00-01

© 2012 Benshaw Inc.

Benshaw retains the right to change specifications and illustrations in text without prior notification. The contents of this document may not be copied without the explicit permission of Benshaw.



**BENSHAW**  
ADVANCED CONTROLS & DRIVES

#### TRADEMARK NOTICE

Benshaw and  **BENSHAW** are registered trademarks of Benshaw Incorporated.

Modbus is a registered trademark of Schneider Electric.

UL is a trademark of Underwriters Laboratories, Incorporated.

# SAFETY INSTRUCTIONS

To prevent injury and property damage, follow these instructions during the installation and operation of the drive.

Incorrect operation due to ignoring these instructions may cause harm or damage. The following symbols are used throughout the manual to highlight important information.



## **DANGER**

This symbol indicates death or serious injury can occur if you do not follow instructions.



## **WARNING**

This symbol indicates the possibility of death or serious injury.



## **CAUTION**

This symbol indicates the possibility of damage to the drive or other components.

■ The meaning of each symbol in this manual and on your equipment is as follows.



This is the safety alert symbol.

Read and follow instructions carefully to avoid a dangerous situation.



This symbol alerts the user to the presence of “dangerous voltage” inside the product that might cause bodily harm or electric shock.

■ This manual should be placed in a location where it can be accessed by users.

■ This manual should be given to the person who actually uses the drive and is responsible for its maintenance.

## WARNING

- Do not remove the cover while power is applied or the unit is in operation.
- Do not operate the drive with the front cover removed. Electric shock can occur due to the exposed terminals and bus bars.
- Do not remove the cover except for periodic inspections or wiring, even if the input power is not applied. The capacitor bank may remain charged for some time even when power is not applied.
- Wiring and periodic inspections should be performed at least 10 minutes after disconnecting the input power and after checking that the DC link voltage is discharged with a meter (below 30VDC).

## CAUTION

- Install the drive on a non-flammable surface. Do not place flammable materials nearby.
- Disconnect the input power if the drive has been damaged. Do not apply power to a damaged drive or to a drive with parts missing.
- Do not connect a resistance directly between the DC Bus terminals (P1 (or P2)) and N. Doing so can result in overheating and damaging the resistor.
- After shutting down or disconnecting the drive, the drive may be hot to the touch.
- Verify that the power-up restart feature is off during servicing to prevent any unexpected operation.
- Do not allow lint, paper, wood chips, dust, metallic chips or other foreign material into the drive.

# OPERATING PRECAUTIONS

## (1) Handling and installation

- The SG-series drive can be heavy. Lift according to the weight of the product. Use a hoist or a crane to move and install the SG-series drive if necessary. Failure to do so may result in personal injury or damage to the drive.
- Do not place heavy items on the drive. Do not stack the drive boxes higher than the number recommended.
- Install the drive according to instructions specified in this manual.
- Check that the drive mounting orientation is correct.
- Do not drop the drive or subject it to hard impacts.
- Verify that the ground impedance is 100 ohms or less for 230 V Class drives and 10 ohms or less for 460V class drives.
- Take protective measures against ESD (Electrostatic Discharge) before touching the PC boards during inspection, installation, or repair.
- The drive is designed for use under the following environmental conditions:

Environment	Ambient temp.	- 10 ~ 40 °C (14°F ~ 104°F)
	Relative humidity	90% Relative Humidity or less (non-condensing)
	Storage temp.	- 20 ~ 65 °C (-4°F ~ 149°F)
	Location	Protected from corrosive gas, combustible gas, oil mist or dust. (Pollution Class 2 environment)
	Altitude, Vibration	Max. 3300 ft. (1000m) above sea level Max. 5.9m/sec <sup>2</sup> (0.6G) or less
	Atmospheric pressure	10~15 PSI (70 ~ 106 kPa, 20.67 in Hg ~ 31.3 in Hg)

## (2) Wiring

- Do not connect power factor correction capacitors, surge suppressors, or a RFI filter to the output of the drive.
- The connection orientation of the motor output cables U, V, W will affect the direction of rotation of the motor. Verify correct wiring before starting drive.
- Incorrect terminal wiring could result in drive and/or equipment damage.
- Reversing the polarity (+/-) of the Px and N terminals could damage the drive.
- Only authorized personnel familiar with Benshaw drives should perform wiring and inspections.

## (3) Trial run

- Check all parameters during operation. Parameter values might require adjustment depending on the application.
- Always apply voltage within the permissible range of each terminal as indicated in this manual. Otherwise, drive damage may result.

#### (4) Operation precautions

- When the Auto restart function is selected the drive will restart after a fault has occurred.
- The Stop key on the keypad is always active regardless of drive control (start/stop) methods set in parameters DRV-03 and DRV-91.
- If Restart after Fault Reset (AFN-21) is set to “yes”, and a fault reset is made with the run command and/or reference signal present, a sudden start will occur. Verify correct setting of this parameter and check that the run command and/or reference signal is turned off in advance of resetting any faults.
- Do not modify the drive.
- Depending on the motor specifications and user ETH overload settings, the motor may not be protected by electronic thermal function of drive.
- The operation of the drive is intended to be controlled by either keypad command or control input signals. Do not use a magnetic contactor or any other device that routinely disconnects the drive and reconnects the drive to the input supply power for the purpose of starting and stopping the motor.
- A noise filter may be installed to reduce the effect of electromagnetic interference. Consult factory for more information.
- In cases with input voltage unbalances, install an AC input reactor.
- Power Factor capacitors and generators may become overheated and damaged due to harmonics created by the drive.
- Use an inverter duty rated motor or take measures to suppress the surge voltage at the motor with a dV/dT filter or equivalent. A surge voltage attributable to wiring constant is generated at the motor terminals and may deteriorate motor insulation.
- The drive can be set to operate a motor at high-speeds. Verify the speed capability of motor and machinery prior to operating drive.
- Holding torque is not produced when using the DC-Brake function. Install separate equipment when holding torque is required.

#### (5) Fault prevention precautions

- If required, provide a safety backup such as an emergency mechanical brake to prevent any hazardous conditions if the drive fails during operation.

#### (6) Maintenance, inspection and parts replacement

- Do not Meggar (hi-pot or insulation resistance) test the power or control circuits of the drive.
- Refer to Chapter 7 for periodic inspection and parts replacement details.

#### (7) General instructions

Many of the diagrams and drawings in this instruction manual may show the drive covers removed. Prior to operating the unit, be sure to restore covers and circuit protection according to specifications.

# Table of Contents

<b>CHAPTER 1. BASIC INFORMATION</b>	<b>1-1</b>
1.1 USING THIS MANUAL	1-1
1.2 GENERAL INFORMATION	1-1
1.3 CONTACTING BENSCHAW/CURTISS WRIGHT FLOW CONTROL CO.	1-2
1.4 INSPECTION	1-3
1.4.1 <i>Drive Model Number</i>	1-3
1.4.2 <i>Installation</i>	1-3
1.4.3 <i>Wiring</i>	1-3
1.5 RECOMMENDED INSTALLATION	1-4
<b>CHAPTER 2. DRIVE RATINGS AND SPECIFICATION</b>	<b>2-1</b>
2.1 RATINGS 230V (7.5~40 HP)	2-1
2.2 RATINGS 460V (7.5~40 HP)	2-1
2.3 RATINGS 460V (50~125HP)	2-2
2.4 RATINGS 460V (150~700HP)	2-2
2.5 RATINGS 575V (7.5~40HP)	2-3
2.6 RATINGS 575V (50~125HP)	2-3
2.7 RATINGS 575V (150 ~ 400 HP)	2-4
2.8 GENERAL SPECIFICATION	2-5
2.9 DIMENSIONS	2-7
<b>CHAPTER 3. INSTALLATION</b>	<b>3-1</b>
3.1 INSTALLATION PRECAUTIONS	3-1
3.2 WIRING	3-3
3.2.1 <i>Basic Wiring</i>	3-3
3.2.2 <i>Wiring Input and Output Power Terminals</i>	3-9
3.2.3 <i>Interference Suppression Measures</i>	3-11
3.2.4 <i>Terminal Layout</i>	3-13
3.2.5 <i>Wire Sizing and Terminal Lugs</i>	3-14
3.2.6 <i>Control Circuit Wiring</i>	3-15
3.2.7 <i>RS-485/Modbus-RTU Circuit Wiring</i>	3-18
3.2.8 <i>Keypad Wiring</i>	3-19
<b>CHAPTER 4. OPERATION</b>	<b>4-1</b>
4.1 KEYPAD PROGRAMMING	4-1
4.1.1 <i>LCD Keypad</i>	4-1
4.1.2 <i>Detailed Description</i>	4-24-2
4.1.3 <i>Parameter Setting and Adjustment</i>	4-3
4.1.4 <i>Parameter Groups</i>	4-4
4.1.5 <i>Easy Start Operation</i>	4-6
4.1.6 <i>Quickstart 1: Start / Stop and Speed Control via the Keypad</i>	4-6
4.1.7 <i>Quickstart 2: Two Wire Start and Control via Speed Potentiometer</i>	4-7
4.1.8 <i>Quickstart 3: Two Wire Start and Control via 4-20mA Analog Input</i>	4-8

## Table of Contents (continued)

<b>CHAPTER 5. PARAMETER LIST</b>	<b>5-1</b>
5.1 DRV (DRIVE GROUP) PARAMETER LIST	5-1
5.2 FUN (FUNCTION GROUP) PARAMETER LIST	5-3
5.3 AFN (ADVANCED FUNCTION GROUP) PARAMETER LIST	5-6
5.4 I/O (INPUT/OUTPUT GROUP) PARAMETER LIST	5-10
5.5 APP (APPLICATION GROUP) PARAMETER LIST	5-16
5.6 EXT (4-20MA OUTPUT OPTION CARD) PARAMETER LIST	5-20
<b>CHAPTER 6. PARAMETER DESCRIPTIONS</b>	<b>6-1</b>
6.1 DRIVE GROUP [DRV]	6-1
6.2 FUNCTION GROUP [FUN]	6-9
6.3 ADVANCED FUNCTION GROUP [AFN]	6-25
6.4 INPUT/OUTPUT GROUP [I/O]	6-39
6.5 APPLICATION GROUP [APP]	6-61
<b>CHAPTER 7. TROUBLE SHOOTING &amp; MAINTENANCE</b>	<b>7-1</b>
7.1 FAULT DISPLAY	7-1
7.2 FAULT REMEDY	7-3
7.3 TROUBLESHOOTING	7-6
7.4 HOW TO CHECK POWER COMPONENTS	7-7
7.5 MAINTENANCE	7-13
7.5.1 <i>Precautions</i>	7-13
7.5.2 <i>Periodic Inspection Summary</i>	7-13
7.5.3 <i>Periodic Inspection</i>	7-14
7.5.4 <i>Parts Replacement</i>	7-15
<b>CHAPTER 8. OPTIONS</b>	<b>8-1</b>
8.1 AVAILABLE OPTIONS	8-1
8.1.1 <i>LCD Keypad</i>	8-2
8.1.2 <i>Remote Keypad Cable</i>	8-2
8.1.3 <i>4 – 20 mA Output Option Card</i>	8-2
8.1.4 <i>DeviceNet Communications Option Card</i>	8-2
8.1.5 <i>Profibus Communications Option Card</i>	8-3
8.1.6 <i>BACnet Communications Option Card</i>	8-3
8.1.7 <i>LonWorks Communications Option Card</i>	8-3
8.1.8 <i>Modbus TCP Option Card</i>	8-3
8.1.9 <i>Dynamic Braking Unit</i>	8-3
8.1.10 <i>Dynamic Braking Resistor(s)</i>	8-6
8.1.11 <i>NEMA TYPE 1 Conduit Box</i>	8-6



## Table of Contents (continued)

<b>CHAPTER 9. RS485/MODBUS-RTU COMMUNICATION</b>	<b>9-1</b>
9.1 INTRODUCTION	9-1
9.1.1 <i>Features</i>	9-1
9.1.2 <i>Connection Guide for Modbus-RTU Communication with PC, PLC and RS232/485</i>	9-1
9.1.3 <i>Before Installation</i>	9-1
9.2 SPECIFICATION	9-2
9.2.1 <i>Performance Specification</i>	9-2
9.2.2 <i>Hardware Specification</i>	9-2
9.2.3 <i>Communication Specification</i>	9-2
9.2.4 <i>Installation</i>	9-2
9.2.5 <i>Communication Parameters</i>	9-3
9.3 OPERATION	9-3
9.3.1 <i>Operating Steps</i>	9-3
9.4 COMMUNICATION PROTOCOL (MODBUS-RTU)	9-4
9.5 PARAMETER CODE LIST	9-5
9.5.1 <i>Common area address 0x0006</i>	9-7
9.5.2 <i>SG operating status in Address E, Common area</i>	9-8
9.6 TROUBLESHOOTING	9-9
<b>APPENDIX A- UL MARKING</b>	<b>I</b>
<b>APPENDIX B- RELATED PARAMETERS</b>	<b>III</b>
<b>APPENDIX C - DECLARATION OF CONFORMITY</b>	<b>V</b>



# Chapter 1. Basic Information

## 1.1 Using This Manual

This manual is divided into 10 sections.

- 1) Basic Information
- 2) Drive Ratings and Specifications
- 3) Installation
- 4) Operation
- 5) Parameter Listing
- 6) Parameter Descriptions
- 7) Troubleshooting & Maintenance
- 8) Options
- 9) RS-485/Modbus-RTU Communications
- 10) Appendices

## 1.2 General Information

Benshaw offers its customers the following:

- Start-up services
- On-site training services
- Technical support
- Detailed documentation
- Replacement parts

**NOTE:** Information about products and services is available by contacting Benshaw. Refer to section 1.3, Contacting Benshaw.

### **Start-Up Services**

Benshaw technical field support personnel are available to do startup and conduct on-site training on the drive operations and troubleshooting.

### **On-Site Training Services**

Benshaw technical field support personnel are available to conduct on-site training on the operations and troubleshooting.

### **Technical Support**

Benshaw technical support personnel are available (at no charge) to answer customer questions and provide technical support over the telephone.

### **Documentation**

Benshaw provides all customers with an RSi-SG Instruction Manual, Benshaw Publication #890046-00.

All RSi-SG drive documentation is available on-line at <http://www.benshaw.cwfc.com>.

### **Replacement Parts**

Spare and replacement parts can be purchased from Benshaw. Contact Benshaw for more information.

**Publication History** Refer to the Revision History located at the end of this manual.

### **1.3 Contacting Benschaw/Curtiss Wright Flow Control Co.**

Information about Benschaw products and services is available by contacting Benschaw at one of the following offices:

**Benschaw Inc.,  
Corporate Headquarters**  
615 Alpha Drive  
Pittsburgh, PA 15238  
Phone: (412) 968-0100  
Fax: (412) 968-5416

**Benschaw Canada Controls Inc.**  
550 Bright Street East  
Listowel, Ontario N4W 3W3  
Canada  
Phone: (519) 291-5112  
Fax: (519) 291-2595

**Benschaw West**  
14715 North 78<sup>th</sup> Way, Suite 600  
Scottsdale, AZ 85260  
Phone: (480) 905-0601  
Fax: (480) 905-0757

Visit the Curtiss Wright / Benschaw website: <http://www.benschaw.cwfc.com>

Technical support for the SG Series drive is available at no charge by contacting Benschaw's customer service department at one of the above telephone numbers. A service technician is available Monday through Friday from 8:00 a.m. to 5:00 p.m. EST.

**NOTE:** An on-call technician is available after normal business hours and on weekends by calling Benschaw at 800-203-2416.

To help assure prompt and accurate service, please have the following information available when contacting Benschaw:

- Name of company
- Telephone number where the caller can be contacted
- Fax number of the caller (if available)
- Benschaw product name
- Benschaw model number
- Benschaw serial number
- Name of product distributor
- Approximate date of purchase
- System voltage
- Voltage, full load current (FLA), and rated speed of motor attached to Benschaw product
- A brief description of the application

## 1.4 Inspection

- Remove the drive from its packing and inspect its exterior for shipping damage. If damage is apparent notify the Shipping agent and your Benshaw sales representative.
- Remove the cover and inspect the drive for any apparent damage or foreign objects. Ensure that all mounting hardware and terminal connection hardware is properly seated, securely fastened, and undamaged.
- Check the nameplate on the SG drive. Verify that the drive unit is the correct horsepower and input voltage for the application.

### 1.4.1 Drive Model Number

The numbering system of the drive is as shown below.

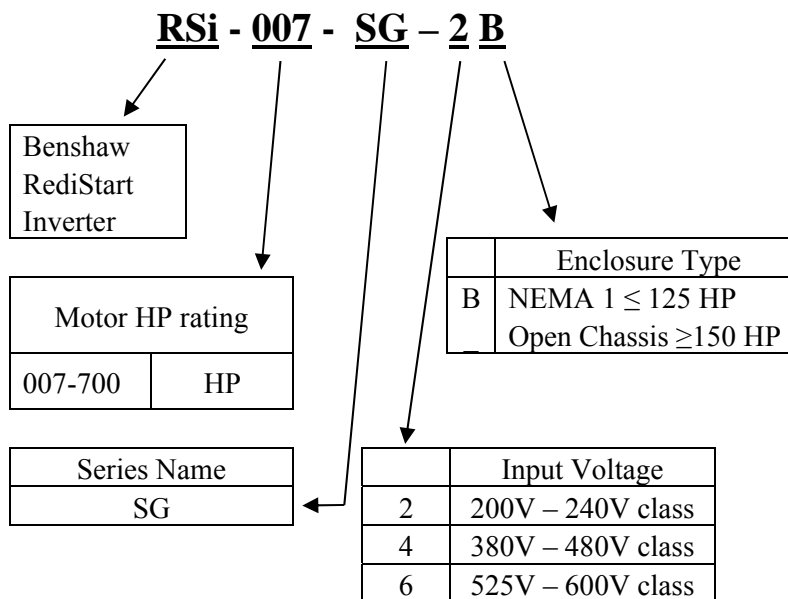

### 1.4.2 Installation

To operate the drive reliably, install the drive in a proper location with the correct orientation and with the proper clearances. Refer to Chapter 3, Installation.

### 1.4.3 Wiring

Connect the power supply, motor and control signals to the terminal blocks. Note that incorrect connections may damage the drive and peripheral devices.

## 1.5 Recommended Installation

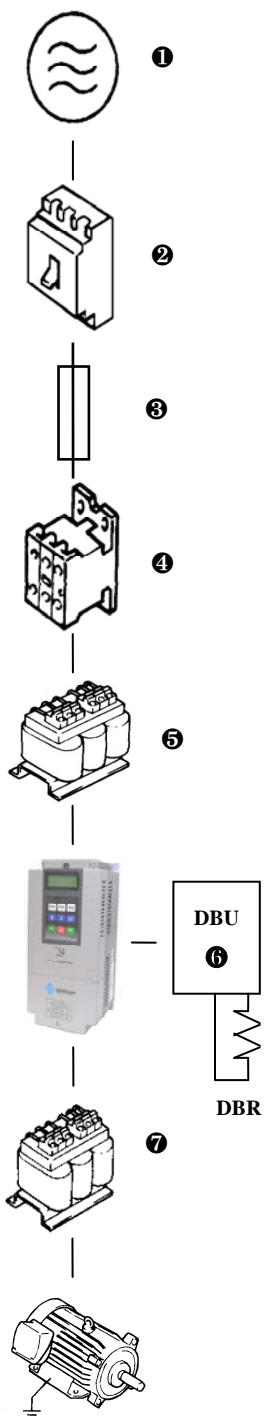

<p>① AC Source Supply</p>	<p>Use a grounded power source with a voltage within the permissible range of drive input voltage rating. Ungrounded power sources will cause nuisance tripping and/or damage to the drive.</p>
<p>② Circuit Breaker or Disconnect Switch</p>	<p>Select Circuit Breaker and/or Disconnect Switch in accordance with applicable national and local codes.</p>
<p>③ Fusing (Recommended)</p>	<p>Select recommended fuses per instruction manual, Appendix A.</p>
<p>④ Inline Contactor (Optional)</p>	<p>When installed, do not use for the purpose of starting or stopping the drive.</p>
<p>⑤ AC Reactor (Recommended)</p>	<p>An AC reactor is recommended to reduce transient currents and voltages that could damage the drive. Reactors also help with harmonic reduction and power factor improvement. A reactor <b>must</b> be used when the KVA rating of the power source is 10 times greater than the KVA rating of the drive.</p>
<p>Installation and Wiring</p>	<p>To reliably operate the drive, install the drive in the proper orientation and with proper clearances. Incorrect terminal wiring could result in equipment damage.</p>
<p>⑥ DBU and DBR Brake Unit (Module) and Resistor</p>	<p>The addition of dynamic braking may be required for applications that require rapid deceleration or are connected to high inertia loads. In such applications, Over Voltage faults will occur unless adequate dynamic braking is added.</p>
<p>⑦ Output Filter (Optional)</p>	<p><b>Output Reactor</b> – Recommended with Non-Inverter Duty rated motors. For lead lengths less than 300 feet. Minimizes drive over current trips. Helps protect motor from over voltages and heating. Reduces motor noise.</p> <p><b>Long Lead Filter</b> - for lead lengths &gt;300 feet up to 1500 feet. Reduces peak voltages at the motor.</p> <p><b>Sine Wave Filter</b> – for lead lengths greater than 1500 feet. Provides sinusoidal wave form to motor, reduces motor noise, vibration and heat.</p>
<p>Motor</p>	<p>Connect to a suitably rated induction motor. Do not connect power factor capacitors, surge arrestors or RFI/EMI filters to the output side of the drive.</p>

**Failure to follow the Recommended Installation Practices may void Warranty**

## Chapter 2. Drive Ratings and Specification

### 2.1 Ratings 230V (7.5~40 HP)

2 3 0 V	RSi__SG-2B		007	010	015	020	025	030	040
	Std. Duty VT	[HP]	7.5	10	15	20	25	30	40
	Motor Rating ( <sup>1</sup> )	[kW]	5.5	7.5	11	15	18.5	22	30
		[A]	24	32	46	60	74	88	115
	Std. Duty CT	[HP]	7.5	10	15	20	25	30	40
	Motor Rating ( <sup>1</sup> )	[kW]	5.5	7.5	11	15	18.5	22	30
		[A]	22	29	42	55	67	80	105
	Heavy Duty	[HP]	5	7.5	10	15	20	25	30
	CT Motor Rating ( <sup>1</sup> )	[kW]	3.7	5.5	7.5	11	15	18.5	22
		[A]	17	23	33	44	54	68	84
Output Rating	Frequency	0.01 ~ 120 Hz							
	Voltage	200 ~ 240 V <sup>(2)</sup>							
Input Rating	Voltage	3 $\phi$ 200 ~ 240 V (-15% ~ +10 %)							
	Frequency	50/60 Hz ( $\pm$ 5 %)							
Weight	Lbs.	10.8	13.2	13.2	28.7	29.8	44.1	44.1	
	Kg	4.9	6	6	13	13.5	20	20	
Protection degree		IP20, UL Enclosed Type 1 for all ratings (provided with conduit box)							

### 2.2 Ratings 460V (7.5~40 HP)

4 6 0 V	RSi__SG-4B		7	10	15	20	25	30	40
	Std. Duty VT Motor Rating ( <sup>1</sup> )	[HP]	7.5	10	15	20	25	30	40
		[kW]	5.5	7.5	11	15	18.5	22	30
		[A]	12	16	24	30	39	45	61
	Std. Duty CT Motor Rating ( <sup>1</sup> )	[HP]	7.5	10	15	20	25	30	40
		[kW]	5.5	7.5	11	15	18.5	22	30
		[A]	11	14	22	27	35	41	55
	Heavy Duty CT Motor Rating ( <sup>1</sup> )	[HP]	5	7.5	10	15	20	25	30
		[kW]	3.7	5.5	7.5	11	15	18.5	22
		[A]	8.8	12	16	22	28	34	44
Output Rating	Frequency	0.01 ~ 120 Hz							
	Voltage	380 ~ 480 V <sup>(2)</sup>							
Input Rating	Voltage	3 $\phi$ 380 ~ 480 V (-15% ~ +10 %)							
	Frequency	50/60 Hz ( $\pm$ 5 %)							
Weight	Lbs.	10.8	13.2	13.2	27.6	28.7	44.1	44.1	
	Kg	4.9	6	6	12.5	13	20	20	
Protection degree		IP20, UL Enclosed Type 1 for all ratings							

2.3 Ratings 460V (50~125HP)

RSi SG-4B		050	060	075	100	125
		Std. Duty	[HP]	50	60	75
VT Motor Rating <sup>(1)</sup>	[kW]	37	45	55	75	90
	[A]	75	91	110	152	183
Std. Duty CT Motor Rating <sup>(1)</sup>	[HP]	50	60	75	100	125
	[kW]	37	45	55	75	90
Heavy Duty CT Motor Rating <sup>(1)</sup>	[A]	68	83	100	139	167
	[HP]	40	50	60	75	100
Heavy Duty CT Motor Rating <sup>(1)</sup>	[kW]	30	37	45	55	75
	[A]	55	66	80	111	134
Output Rating	Frequency	0.01 ~ 120 Hz				
	Voltage	380 ~ 480 V <sup>(2)</sup>				
Input Rating	Voltage	3 $\phi$ 380 ~ 480 V (-15% ~ +10 %)				
	Frequency	50/60 Hz ( $\pm$ 5 %)				
Weight <sup>(3)</sup>	Lbs.	59.5	59.5	64	92.6	94.8
	Kg	27	27	29	42	43
Protection degree		IP20, UL Enclosed Type 1 for all ratings (provided with conduit box)				

2.4 Ratings 460V (150~700HP)

RSi SG-4		150	200	250	350	400	500	600	700
Std. Duty VT Motor Rating <sup>(1)</sup>	[HP]	150	200	250	350	400	500	600	700
	[kW]	110	132	160	220	280	315	375	450
Std. Duty CT Motor Rating <sup>(1)</sup>	[A]	223	264	325	432	547	613	731	877
	[HP]	150	200	250	300	400	450	500	600
Heavy Duty CT Motor Rating <sup>(1)</sup>	[kW]	90	110	132	160	220	280	315	375
	[A]	204	242	302	396	501	562	670	804
Heavy Duty CT Motor Rating <sup>(1)</sup>	[HP]	125	150	200	250	300	350	400	500
	[kW]	90	110	132	160	220	280	315	375
Weight	[A]	164	194	240	317	401	450	536	643
	Lbs.	223	223	252	441	441	536	838	838
Output Rating	Frequency	0.01 ~ 120 Hz							
	Voltage	380 ~ 480 V <sup>(2)</sup>							
Input Rating	Voltage	3 $\phi$ 380 ~ 480 V (-15% ~ +10 %)							
	Frequency	50/60 Hz ( $\pm$ 5 %)							
Weight	Kg	101	101	114	200	200	243	380	380
	Protection degree		IP00, UL Open Type for all ratings						



**2.5 Ratings 575V (7.5~40HP)**

<b>RSi SG-6B</b>		<b>007</b>	<b>010</b>	<b>015</b>	<b>020</b>	<b>025</b>	<b>030</b>	<b>040</b>	
<b>575V</b>	Std. Duty VT Motor Rating <sup>(1)</sup>	[HP]	7.5	10	15	20	25	30	40
		[kW]	5.5	7.5	11	15	18.5	22	30
		[A]	9	12	17	23	27	34	43
	Std. Duty CT Motor Rating <sup>(1)</sup>	[HP]	7.5	10	15	20	25	30	40
		[kW]	5.5	7.5	11	15	18.5	22	30
		[A]	8.2	11	15.5	21	24.7	31	39
	Heavy Duty CT Motor Rating <sup>(1)</sup>	[HP]	5	7.5	10	15	20	25	30
		[kW]	3.7	5.5	7.5	11	15	18.5	22
		[A]	6.6	9	12	17	19.8	25	31.5
Output Rating	Frequency	0.01 ~ 120 Hz							
	Voltage	525 ~ 600 V <sup>(2)</sup>							
Input Rating	Voltage	3 $\phi$ 525 ~ 600 V (-15% ~ +10 %)							
	Frequency	50/60 Hz ( $\pm$ 5 %)							
Weight	Lbs.	14.4	15.5	15.5	25.8	25.8	41.7	41.7	
	Kg	6.5	7	7	11.7	11.7	18.9	18.9	
Protection degree		IP20, UL Enclosed Type 1 for all ratings							

**2.6 Ratings 575V (50~125HP)**

<b>RSi SG-6B</b>		<b>050</b>	<b>060</b>	<b>075</b>	<b>100</b>	<b>125</b>	
<b>575V</b>	Std. Duty VT Motor Rating <sup>(1)</sup>	[HP]	50	60	75	100	125
		[kW]	37	45	55	75	90
		[A]	55	64	80	104	128
	Std. Duty CT Motor Rating <sup>(1)</sup>	[HP]	50	60	75	100	125
		[kW]	37	45	55	75	90
		[A]	50	58.6	73	95	117
	Heavy Duty CT Motor Rating <sup>(1)</sup>	[HP]	40	50	60	75	100
		[kW]	30	37	45	55	75
		[A]	43	55	64	80	104
Output rating	Frequency	0.01 ~ 120 Hz					
	Voltage	525 ~ 600 V <sup>(2)</sup>					
Input Rating	Voltage	3 $\phi$ 525 ~ 600 V (-15% ~ +10 %)					
	Frequency	50/60 Hz ( $\pm$ 5 %)					
Weight <sup>(3)</sup>	Lbs.	70.65	70.65	70.65	101.5	101.5	
	Kg	32	32	32	46	46	
Protection degree		IP20, UL Enclosed Type 1 for all ratings (provided with conduit box)					

2.7 Ratings 575V (150 ~ 400 HP)

<b>RSi SG-6</b>		<b>150</b>	<b>200</b>	<b>250</b>	<b>350</b>	<b>400</b>
Std. Duty VT Motor Rating <sup>(1)</sup>	[HP]	150	200	250	350	400
	[kW]	110	132	160	220	280
	[A]	150	200	242	333	424
Std. Duty CT Motor Rating <sup>(1)</sup>	[HP]	150	200	250	350	400
	[kW]	110	132	160	220	280
	[A]	137	184	222	305	389
Heavy Duty CT Motor Rating <sup>(1)</sup>	[HP]	125	150	150	250	300
	[kW]	90	110	132	160	220
	[A]	128	147	177	244	311
Output rating	Frequency	0.01 ~ 120 Hz				
	Voltage	525 ~ 600 V <sup>(2)</sup>				
Input rating	Voltage	3φ 525 ~ 600 V (-15% ~ +10 %)				
	Frequency	50/60 Hz (± 5 %)				
Weight	Lbs.	223	255	255	450	450
	Kg	101	116	116	204	204
Protection degree		IP00, UL Open Type				

5  
7  
5  
V

## 2.8 General Specification

Cooling method		Forced air cooling	
Short Circuit Rating		100KA, Suitable for use on a circuit capable of delivering not more than 100,000 A(rms) Symmetrical amperes when protected by a breaker or fuse with an interrupt rating of not less than 100,000 A(rms).	
Agency Approvals		UL and cUL listed, CE marked	
CONTROL	Control Method	V/F, Sensorless Vector, Slip Compensation, Easy Start Selectable	
	Frequency Setting Resolution	Digital Reference: 0.01 Hz (Below 100 Hz), 0.1 Hz (Over 100 Hz) Analog Reference: 0.01 Hz / 60 Hz	
	Frequency Accuracy	Digital: 0.01 % of Max. Output Frequency Analog: 0.1 % of Max. Output Frequency	
	V/F Ratio	Linear, Squared Pattern, User V/F	
	Overload Capacity	110% per 1 min VT standard duty, 120% per 1 min CT standard duty, 150% per 1 min heavy duty	
	Voltage Boost	Manual Voltage Boost (0 ~ 15 % programmable), Auto Boost	
OPERATION	Operation Method	Keypad / Terminal / Communication Operation	
	Frequency Setting (Isolated)	Analog: 0~12V, -12V~ +12V, 4~20mA or 0~20mA, Pulse, Ext-PID Digital: Keypad	
	Input Signal (Isolated)	Start Signal	Forward, Reverse
		Multi-Step	Max 18 Speeds can be set including Jog, Dwell via (4) Multi-Function Terminals
		Acc/Dec Time Pattern	0.1~ 6,000 sec. Linear, U-Curve, S-Curve Selectable
		Inverter Disable	Interrupts the output of the drive.
		Jog	Jog operation
		Fault Reset	Trip status is reset when a fault indication is active.
	Output signal	Operating Status	Relay Output contacts (Isolated). (4) Form A (Ax-Cx) - AC 250V, 1A. Programmable to: Frequency Detection Level, Overload Alarm, Stall, Over Voltage, Low Voltage, Inverter Overheat/Run/Stop/Steady/Ready, Inverter Bypass, Speed Searching
		Fault Output	Relay Output contacts (Isolated). Form C (3A, 3C, 3B) – AC 250V 1A, DC 30V 1A
		Meter/Indicator	Output Voltage: (2) 0~10VDC Outputs (Non-Isolated): Choose from: Output Frequency, Output Current, Output Voltage, DC Link Voltage, Power (Watts).
Operation Functions	DC Braking, Frequency Limit, Frequency Jump, 2 <sup>nd</sup> Function, Slip Compensation, Reverse Rotation Prevention, Auto Restart, Inverter Bypass, Auto-Tuning, PID Control, Flying Start, Safety Stop, Flux Braking, Low Leakage, Pre-PID, Dual-PID, MMC, Easy Start, Pre-heater		

**General Specification (continued)**

PROTECTION	Inverter Trips		Over Voltage, Low Voltage, Over Current, Ground Fault, Inverter Overheat, Motor Overheat, Output Phase Open, Overload Protection, External Fault 1, 2, Communication Error, Loss of Speed Command, Hardware Fault, Option Fault
	Inverter Alarms		Stall Prevention, Overload Alarm, Over Heat, Thermal Sensor Fault
	Momentary Power Loss		Below 8.3 msec: Continuous operation Above 8.3 msec: Auto restart active (AFN-22) Above 1 sec: Auto restart active (AFN-22) and for high inertia loads, Safety Stop (FUN-28) set to “Yes”.
DISPLAY	Keypad	Operation Information	Output Frequency, Output Current, Output Voltage, Frequency Set Value, Operating Speed, DC Link Voltage, Integrating Wattmeter, Run-Time, Last Trip Time
		Trip Information	Trip Indication when a fault occurs. Maximum of five (5) faults are log along with the Last Trip Time.
ENVIRONMENT	Ambient Temperature		-10 C (14F) ~ 40 C (104F) (Derate by 20% for use at 50C ambient)
	Storage Temperature		-20 C (-4F) ~ 65 C (149F)
	Ambient Humidity		Less Than 90 % RH Max. (Non-Condensing)
	Altitude		Below 3300ft (1000m), Derate 1% (drive current) for every 300ft above 3300 ft.
	Vibration		Below 5.9m/sec <sup>2</sup> (=0.6g)
Application Site		Pollution degree 2, No Corrosive Gas, Combustible Gas, Oil Mist, or Dust	

- (1) Standard duty VT motor rating based on a 110% overload for 1 minute.  
Standard duty CT motor rating based on a 120% overload for 1 minute.  
Heavy Duty motor ratings based on a 150% overload for 1 minute.  
Horsepower ratings based on 4-Pole motor specifications at 230V, 460V or 575V input voltages. Operation at lower input voltages or with motors with 6 or more poles may require the use of a larger drive depending on actual motor rating.
- (2) Maximum output voltage will not exceed the input voltage. An output voltage less than the input voltage may be programmed if necessary.
- (3) The standard conduit box attachment adds 1.8kg (4 lbs.) to the weight of the drive.

2.9 Dimensions

- 1) 7.5 HP, 230V
- 7.5 HP, 460V

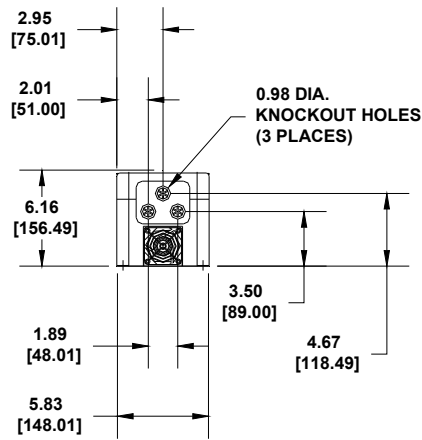
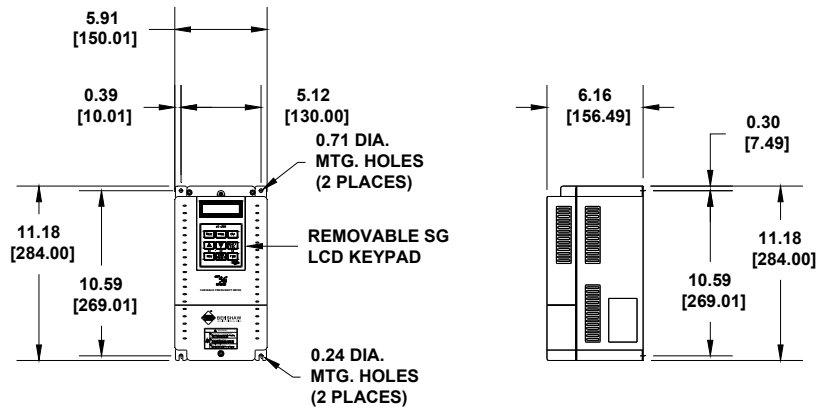

PART NUMBER	VOLTS	HP
VFD-RSI-007-SG-2B	230	7.5
PART NUMBER	VOLTS	HP
VFD-RSI-007-SG-4B	460	7.5

2) 10 HP ~ 15 HP, 230V  
 10 HP ~ 15 HP, 460V

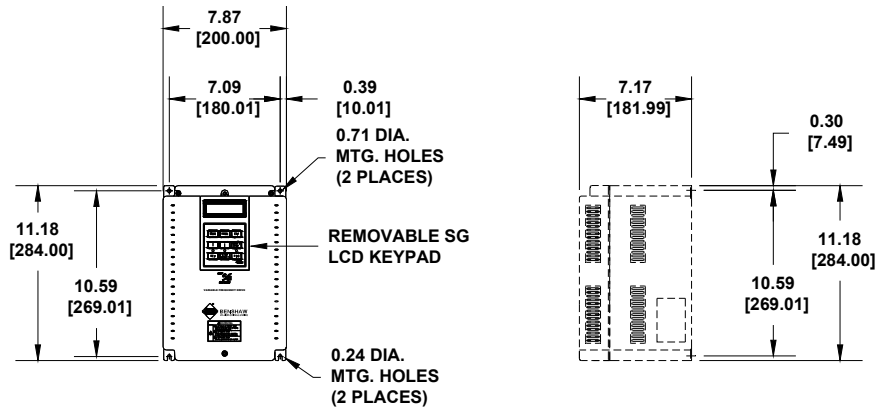

FRONT VIEW

RIGHT SIDE VIEW

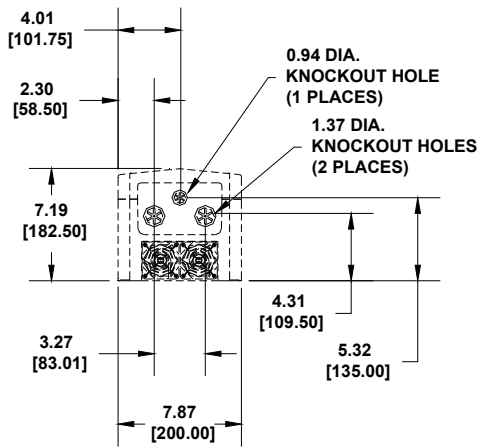

BOTTOM VIEW

PART NUMBER	VOLTS	HP
VFD-RSI-010-SG-2B	230	10
VFD-RSI-015-SG-2B	230	15

PART NUMBER	VOLTS	HP
VFD-RSI-010-SG-4B	460	10
VFD-RSI-015-SG-4B	460	15

3) 7.5 HP ~ 15 HP, 600V

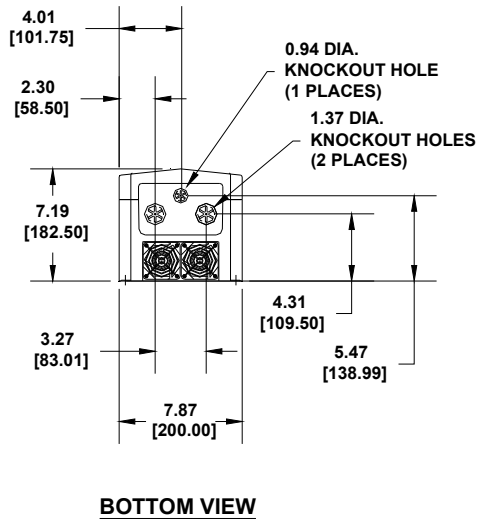
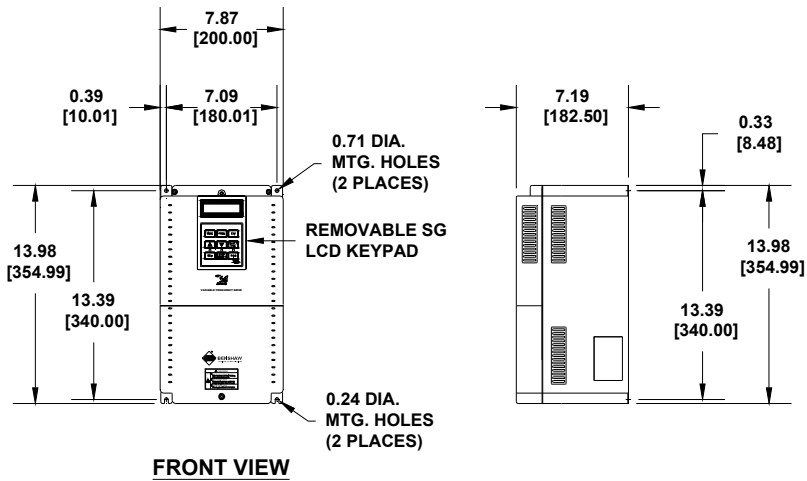

PART NUMBER	VOLTS	HP
VFD-RSI-007-SG-6B	600	7.5
VFD-RSI-010-SG-6B	600	10
VFD-RSI-015-SG-6B	600	15

4) 20 HP ~ 25 HP, 230V

20 HP ~ 25 HP, 460V

20 HP ~ 25 HP, 600V

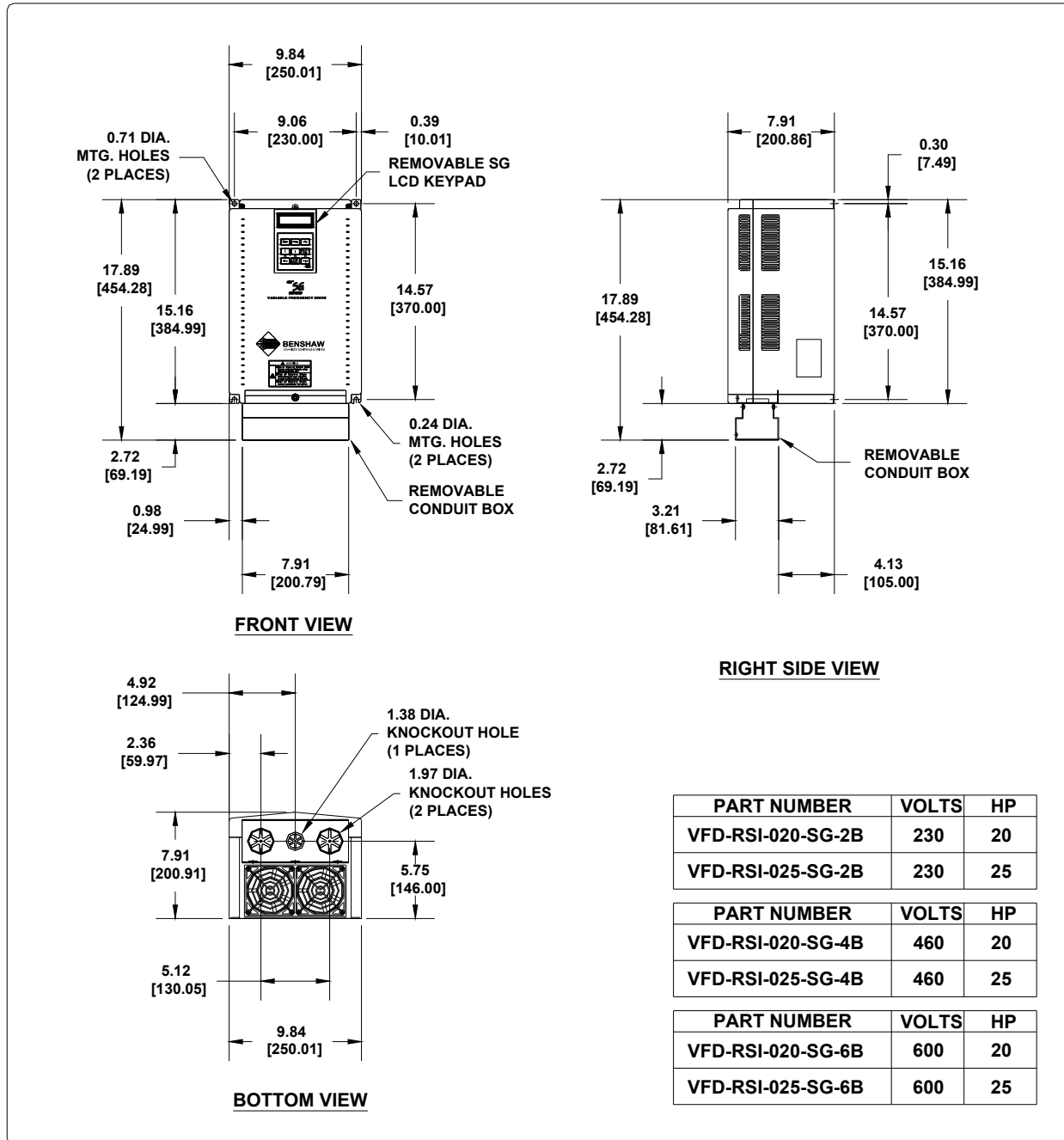



- 5) 30 HP ~ 40 HP, 230V
- 30 HP ~ 40 HP, 460V
- 30 HP ~ 40 HP, 600V

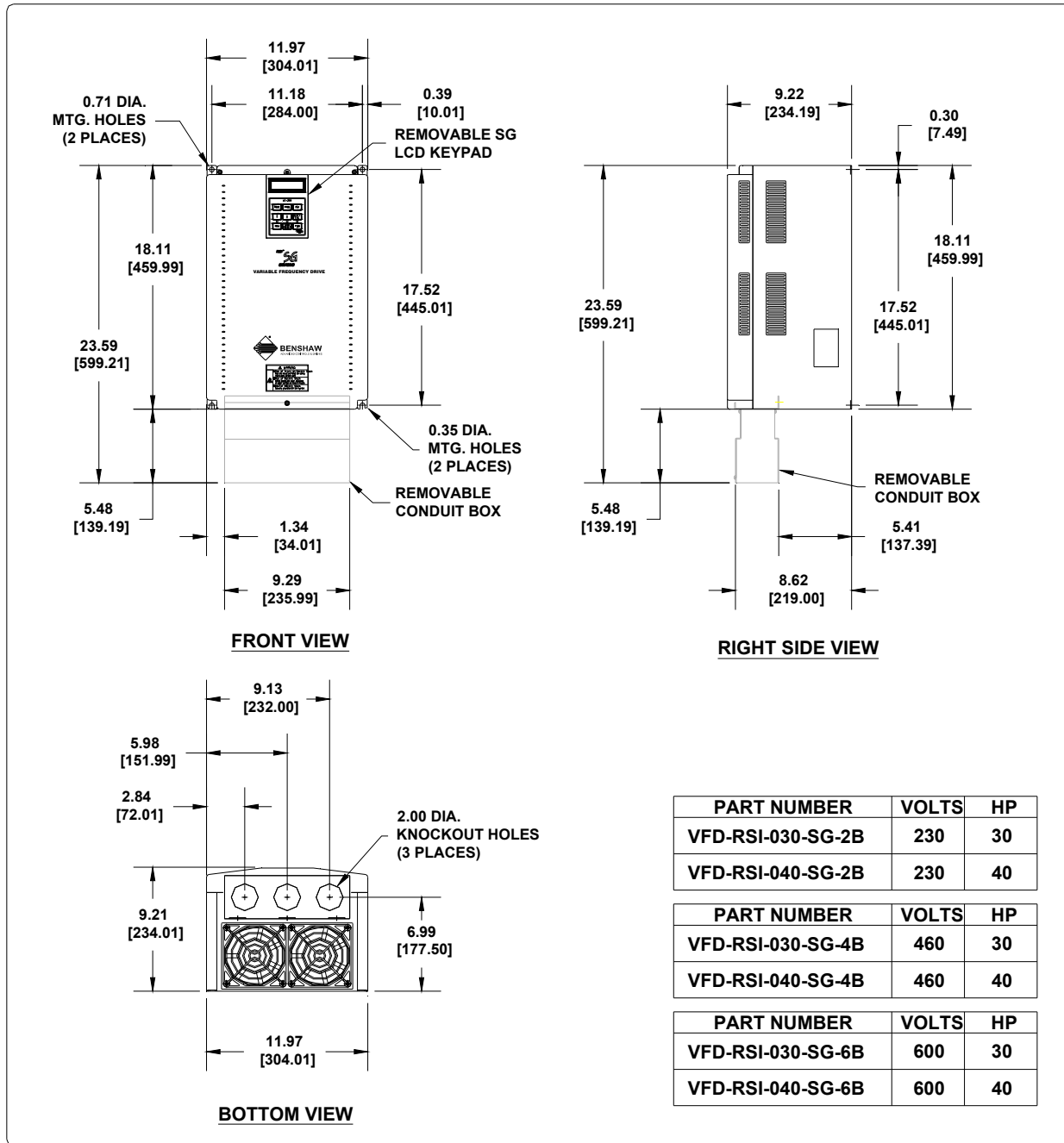

6) 50 HP ~ 60 HP, 460V

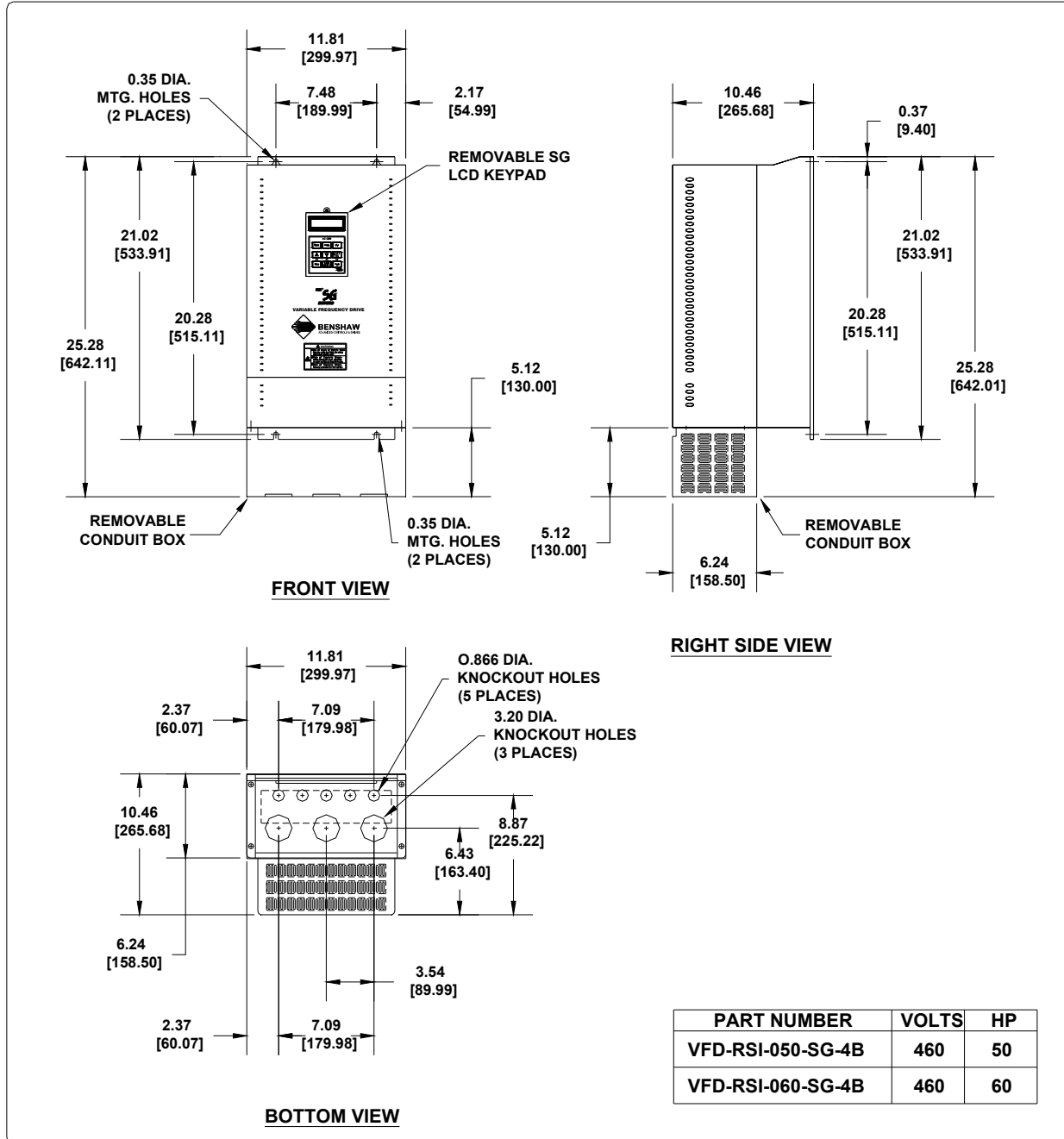

7) 75 HP, 460V

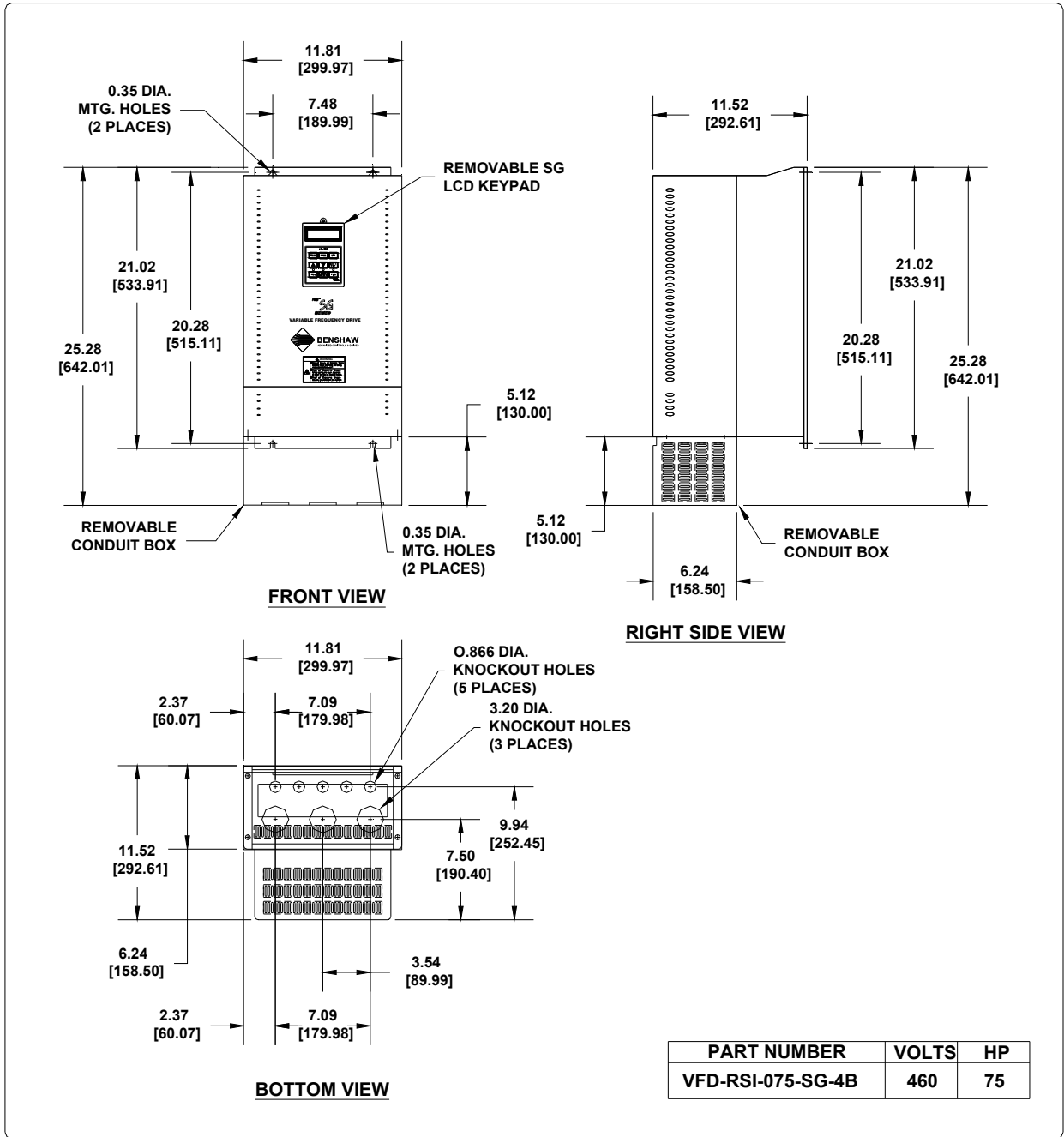

8) 50 HP ~ 75 HP, 600V

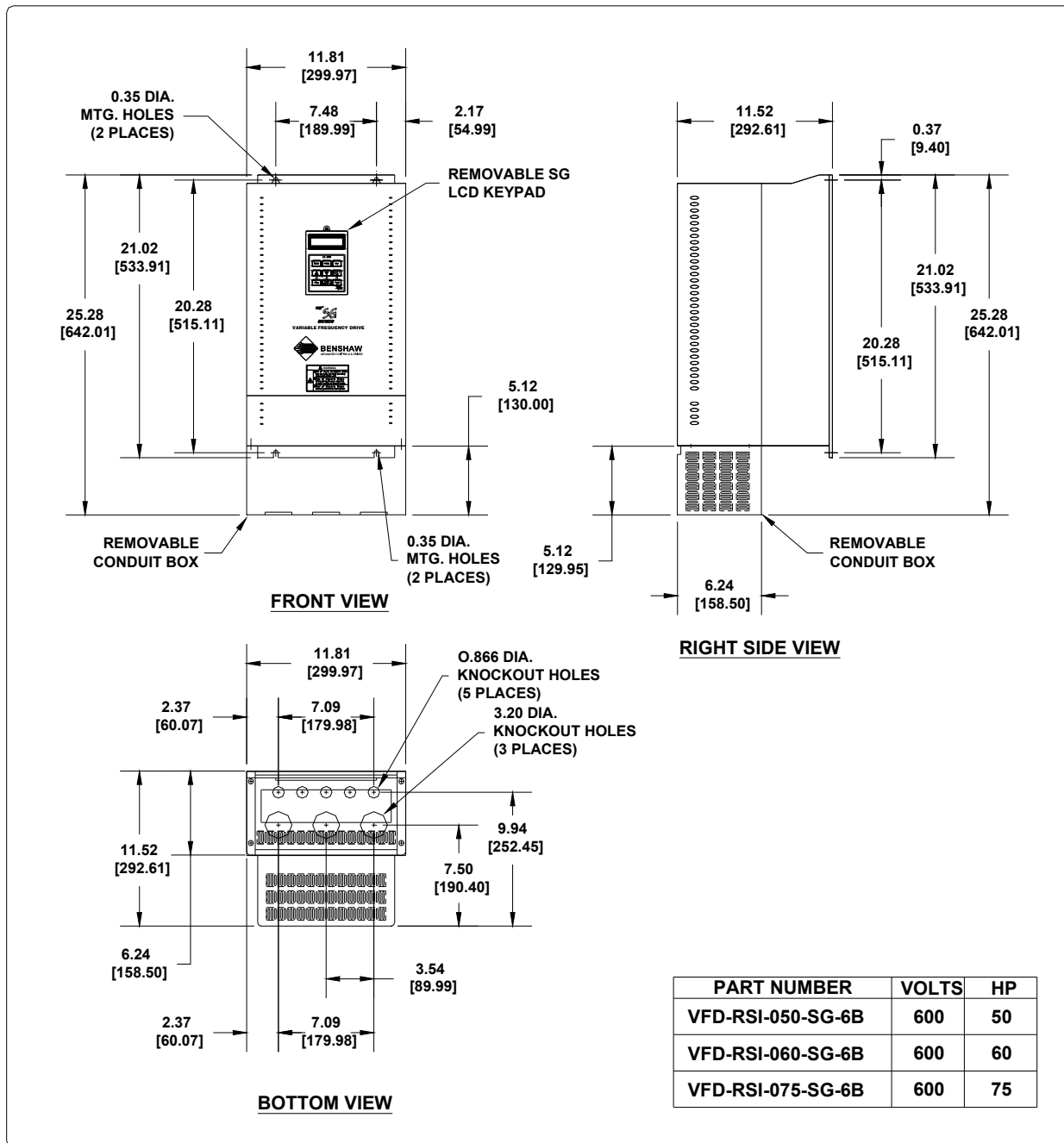

9) 100 HP ~ 125 HP, 460V  
 100 HP ~ 125 HP, 600V

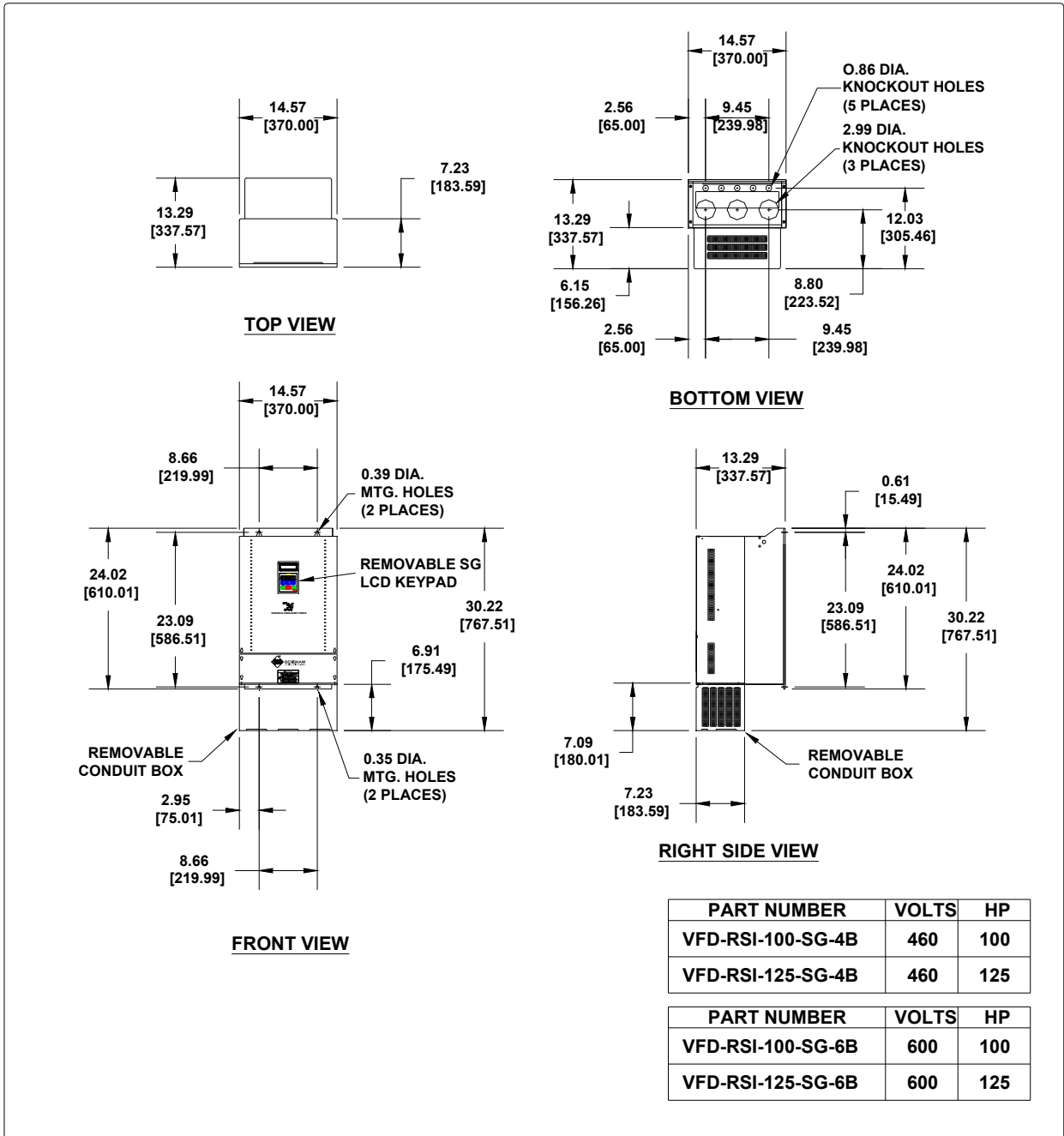

10) 150 HP ~ 200 HP, 460V  
150 HP, 600V

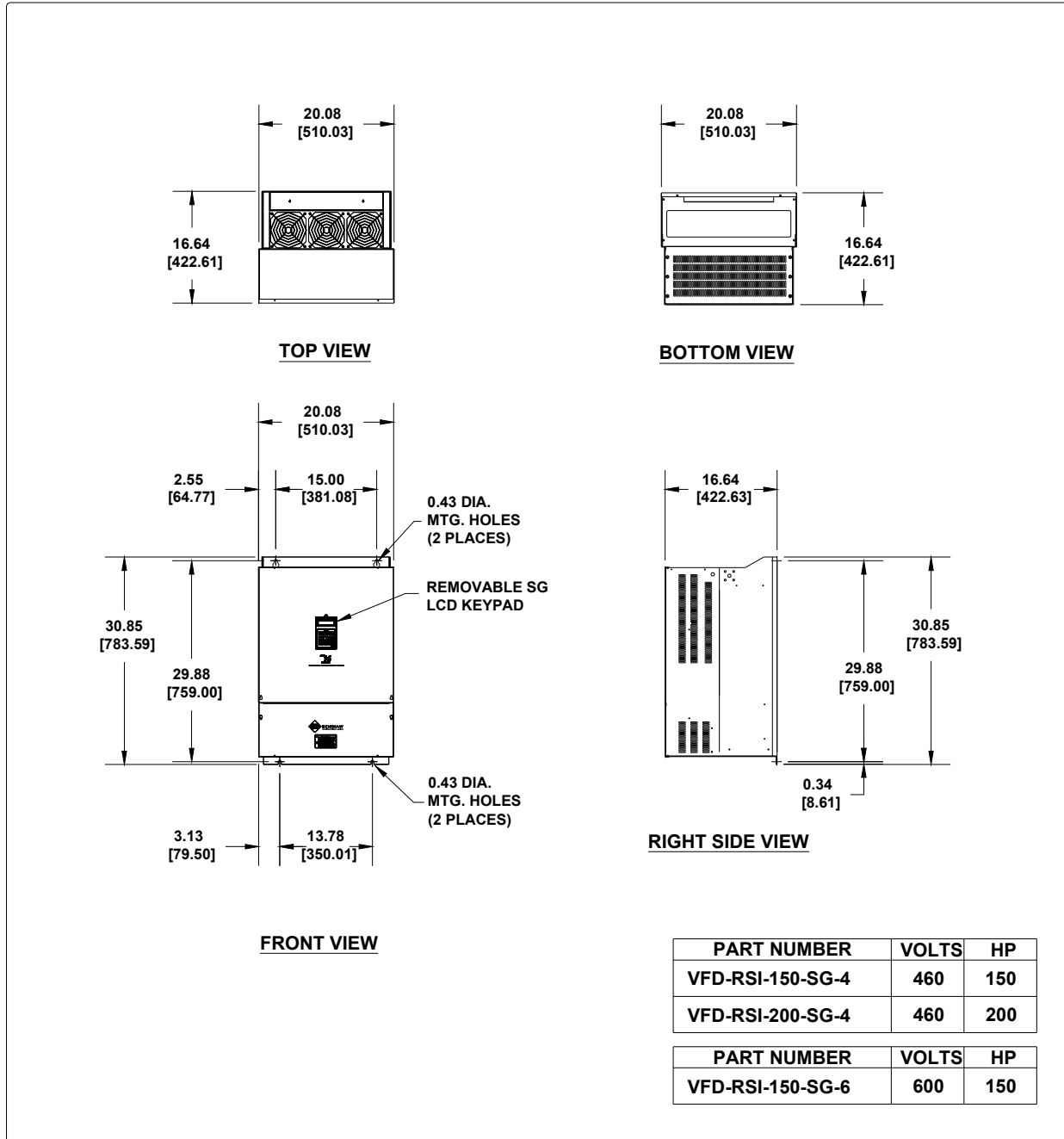

11) 250 HP, 460V

200 HP ~ 250 HP, 600V

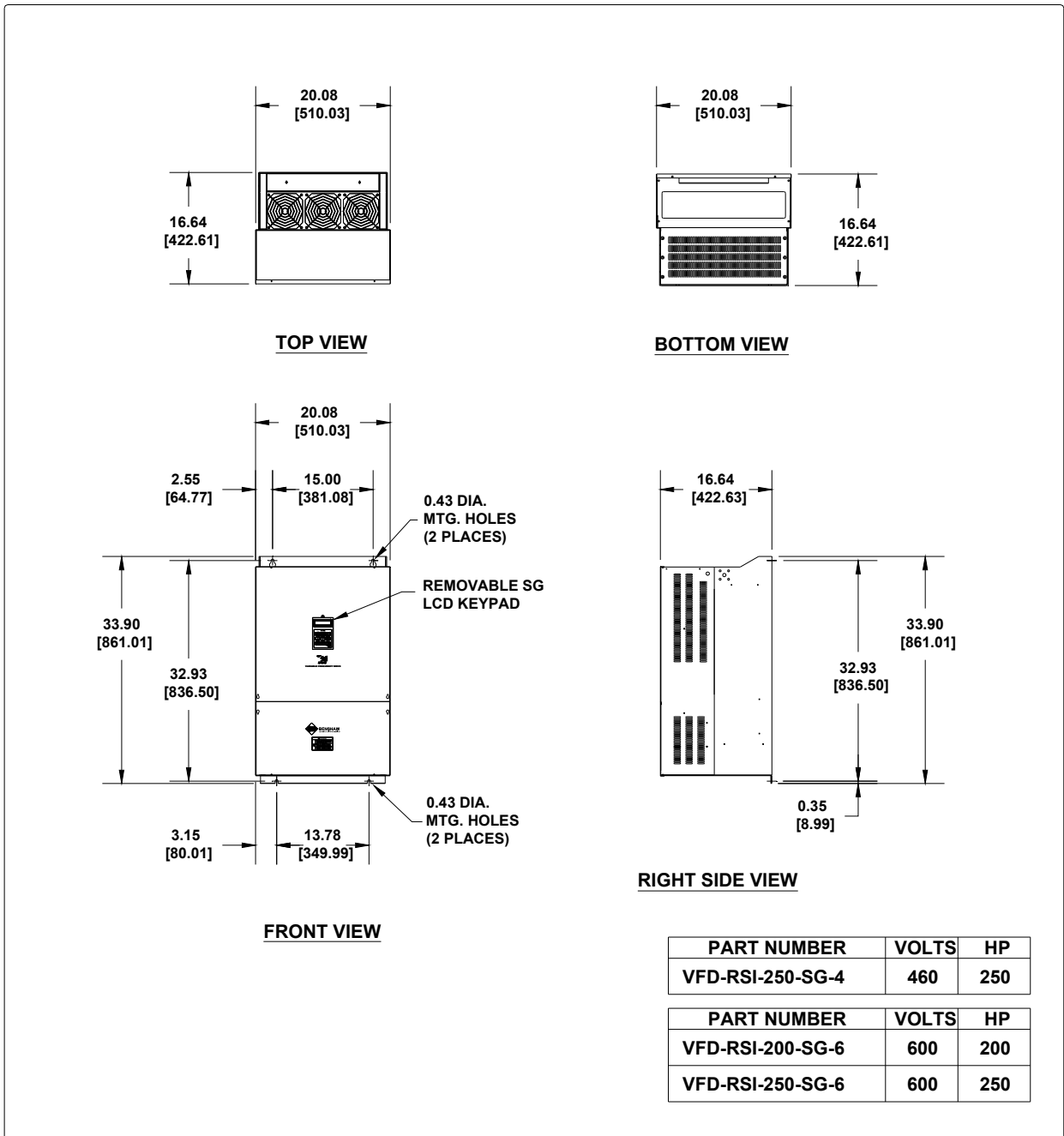

12) 350 HP ~ 400 HP, 460V

350 HP ~ 400 HP, 600V

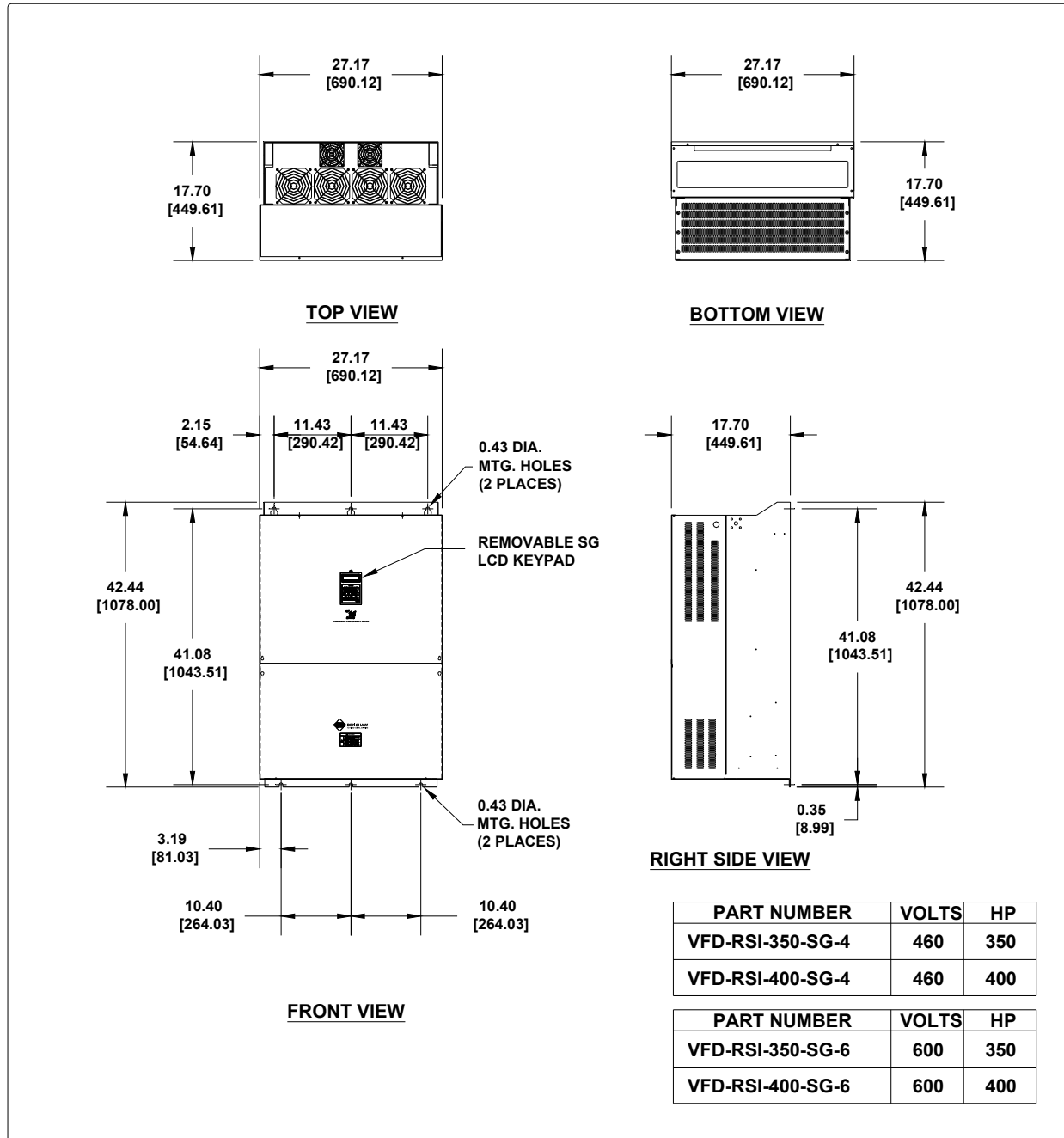



13) 500 HP, 460V

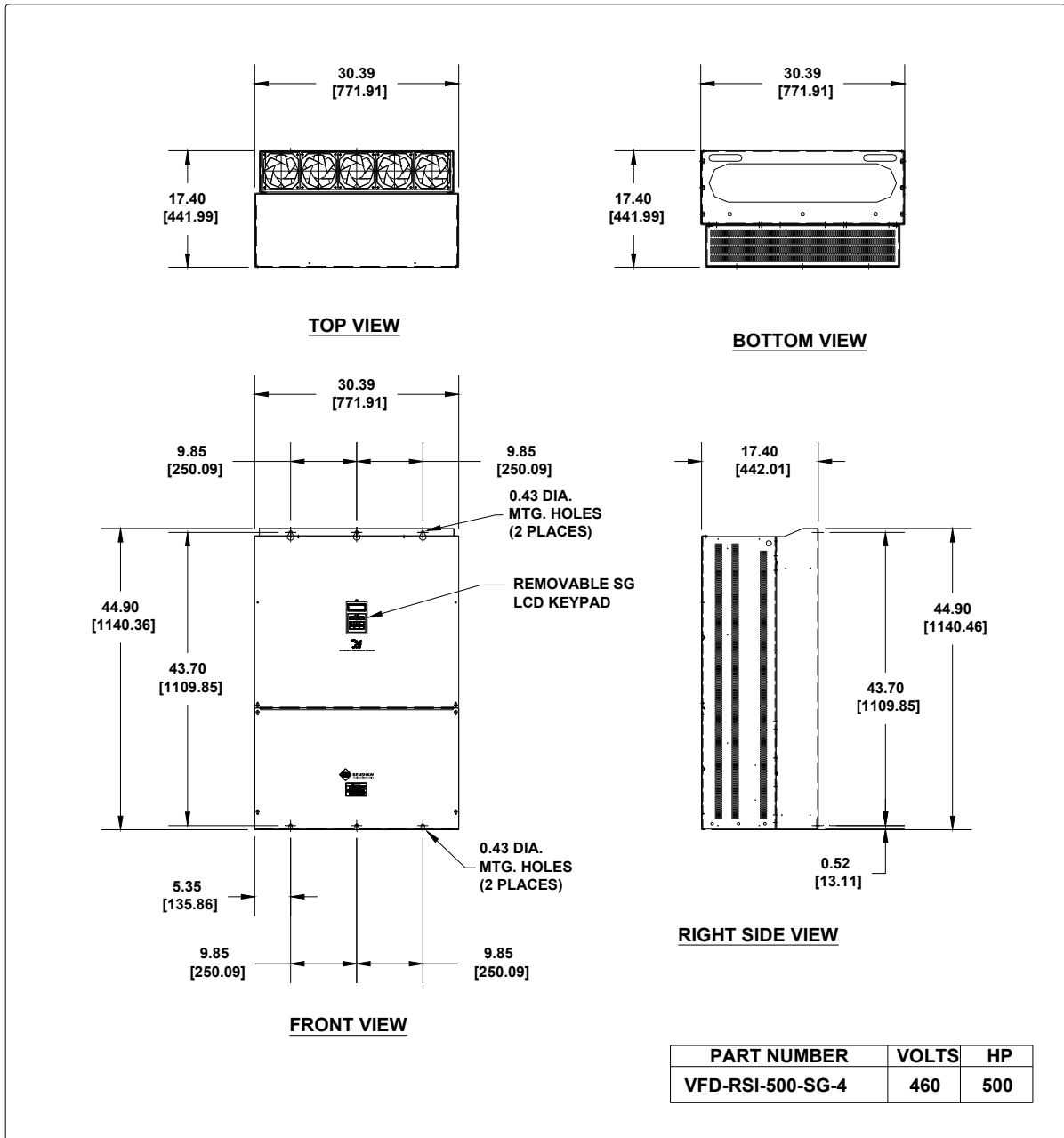

14) 600 HP ~ 700 HP, 460V

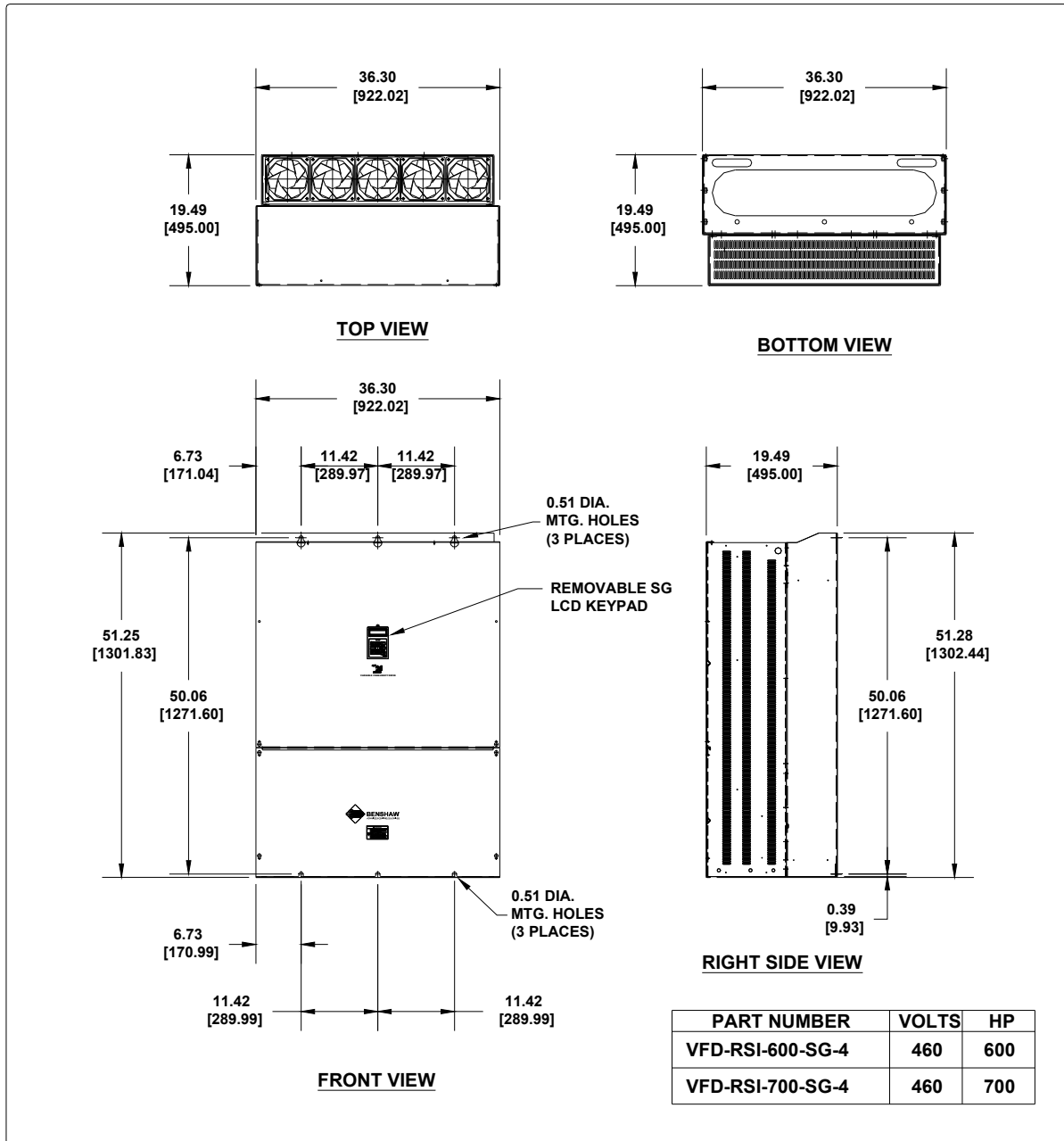

---

■ Notes :



## Chapter 3. Installation

### 3.1 Installation Precautions

- 1) Handle the drive with care to prevent damage to the plastic components. Do not hold the drive by the front cover.
- 2) Do not mount the drive in a location where excessive vibration ( $5.9 \text{ m/sec}^2$  or less) is present such as installing the drive on a press or other moving equipment.
- 3) Install in a location where temperature is within the permissible range ( $-10\sim 40^\circ\text{C}$ ).

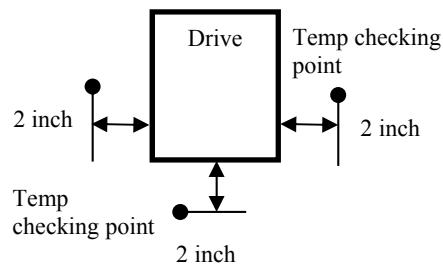

- 4) The drive will be very hot during operation. Install it on a non-combustible surface.
- 5) Mount the drive on a flat, vertical and level surface. Drive orientation must be vertical (top up) for proper heat dissipation. When mounting the drive in a location (or enclosure) WITHOUT additional forced ventilation leave sufficient air space clearances around the drive.

	$\leq 30 \text{ HP}$	$\geq 40 \text{ HP}$
A	4"	20"
B	2"	8"

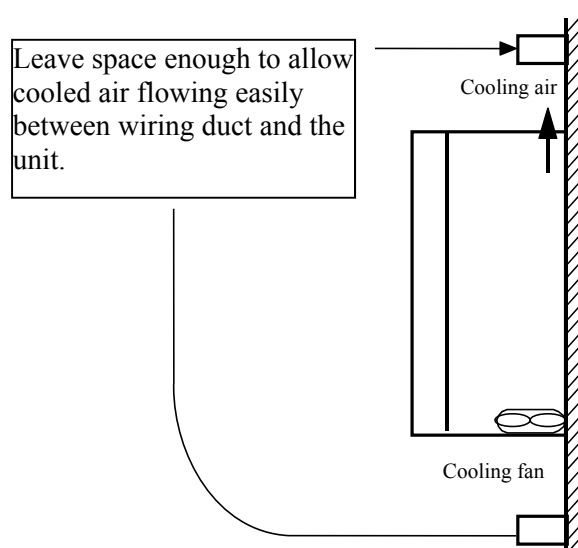
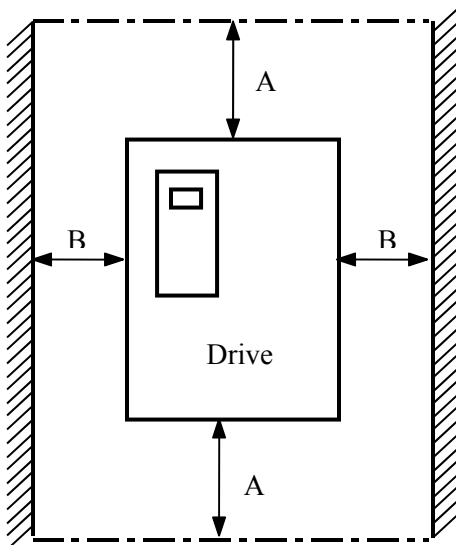

## Chapter 3 - Installation

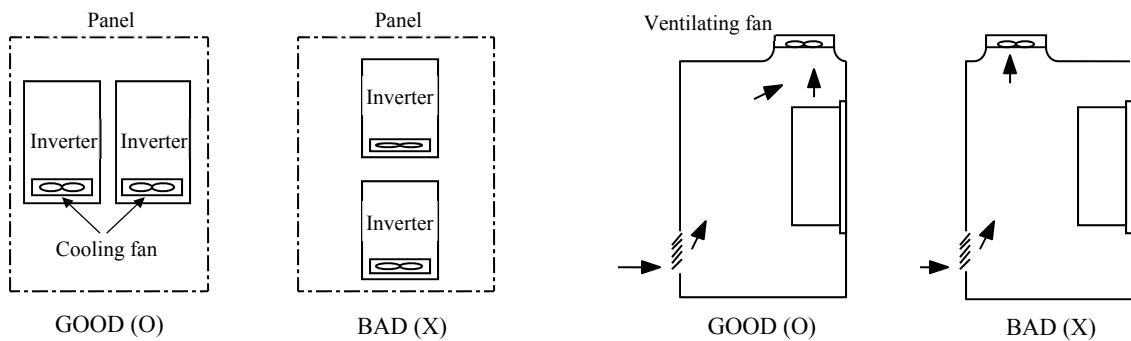

- 6) Do not mount the drive in direct sunlight or near other heat sources.
- 7) The drive shall be mounted in a Pollution Class 2 environment. If the drive is going to be installed in an environment with a high probability of dust, metallic particles, mists, corrosive gases, or other contaminants, the drive must be located inside the appropriate electrical enclosure of the proper NEMA or IP rating.
- 8) When two or more drives are installed or a ventilation fan is mounted in the drive panel, the drives and ventilation fan must be installed in proper positions with extreme care taken to keep the ambient temperature of the drives below the permissible value. If they are installed in improper positions, the ambient temperature of the drives will rise.



[When installing several inverters in a panel]

[When installing a ventilating fan in a panel]

- 9) Install the drive using appropriate sized screws or bolts to insure the drive is firmly fastened.

 <b>CAUTION</b>	
	<p>■ <b>Risk of Electric Shock</b></p> <p>More than one source of power may be present. More than one disconnect switch may be required to de-energize the equipment before servicing.</p>

### 3.2 Wiring

#### 3.2.1 Basic Wiring

1) For 7.5~40 HP (5.5~30kW)

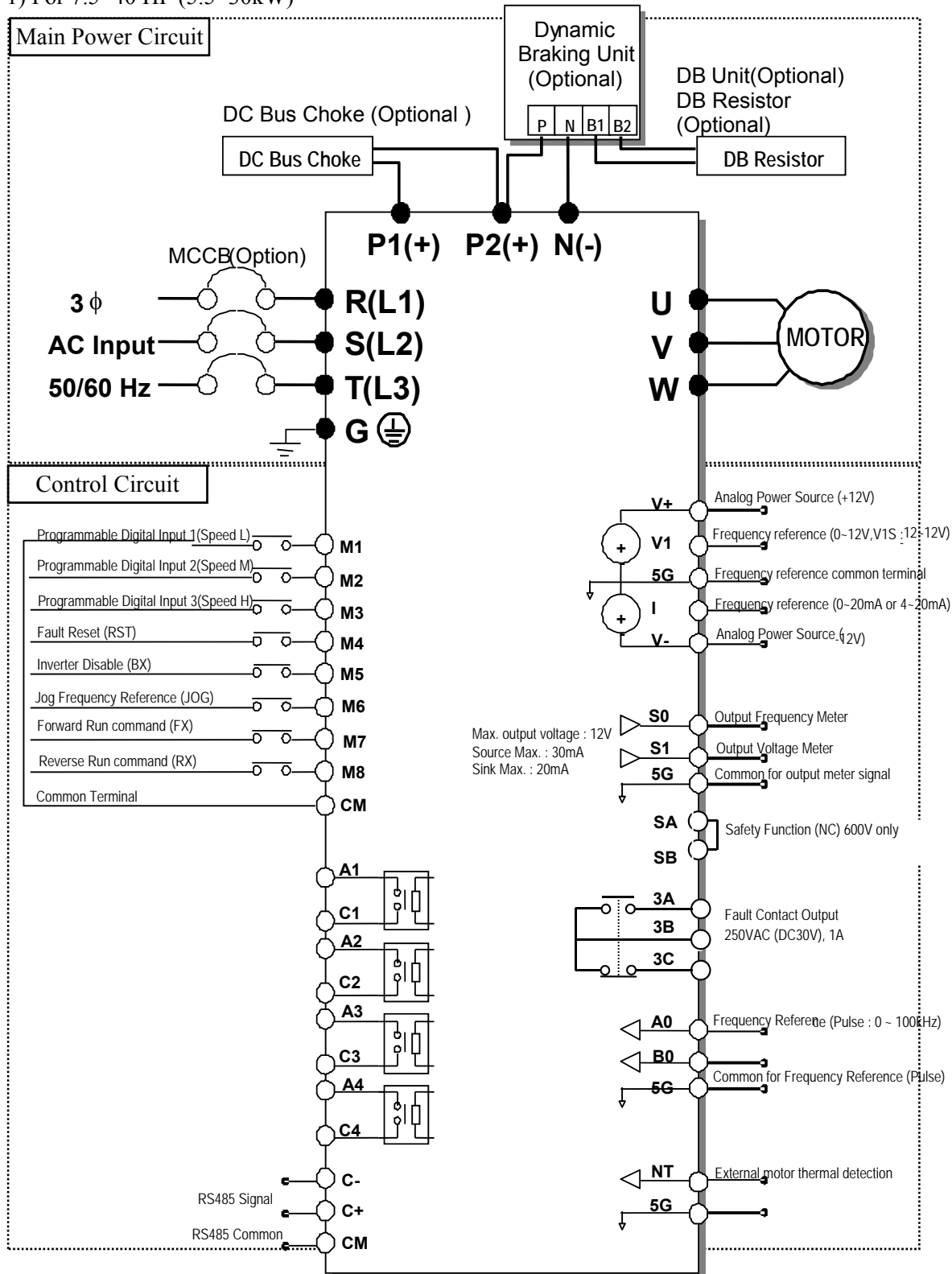

Note: 1) 5G is Common Ground for Analog Input and Outputs.  
 2) Use terminal V1 for (0-12V) input or V1S for (3~12V) input

2) For 50~125HP (37~90KW) and 500~700HP (315~450kW)

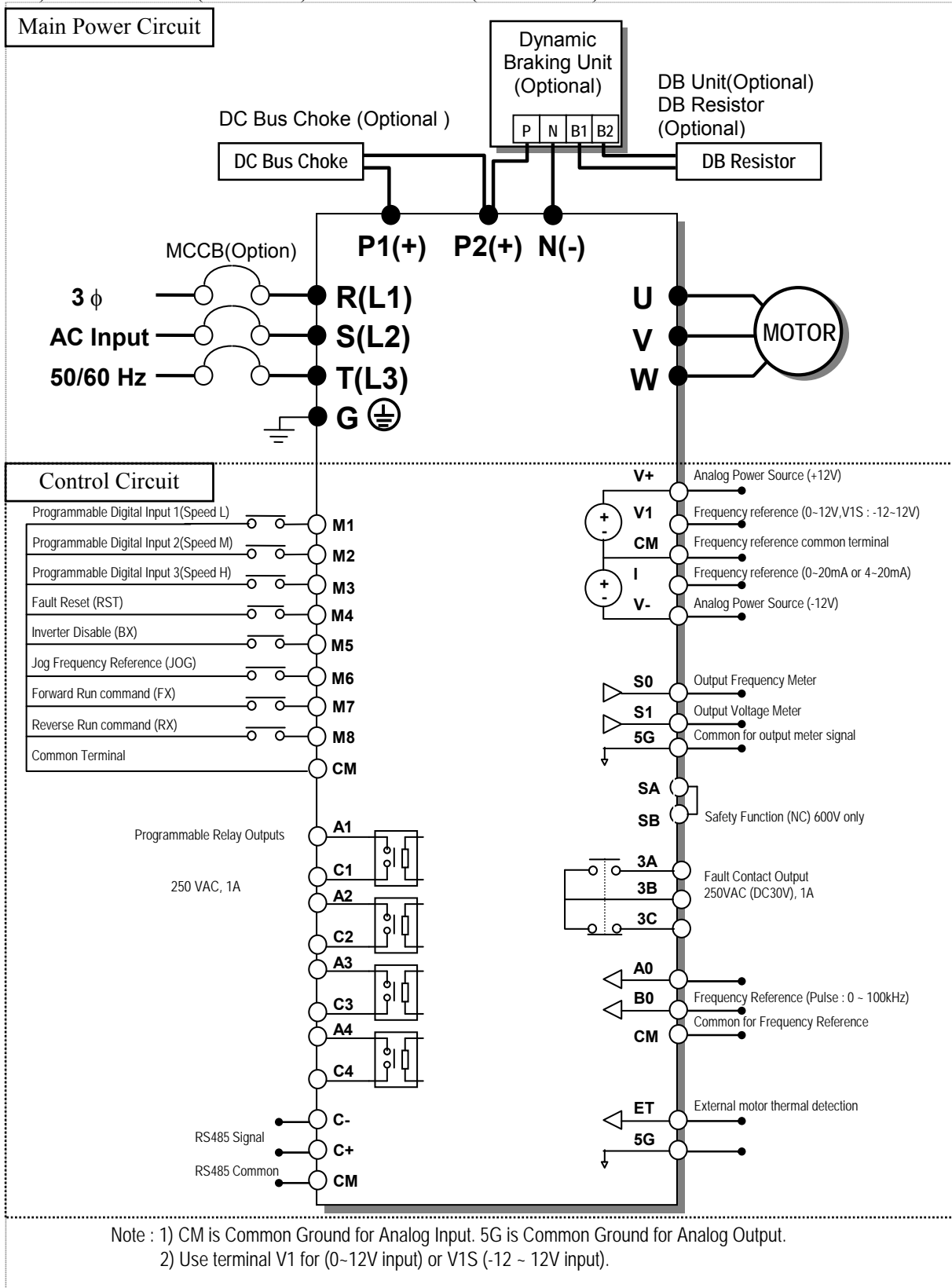



3) For 150~400HP (110~280kW)

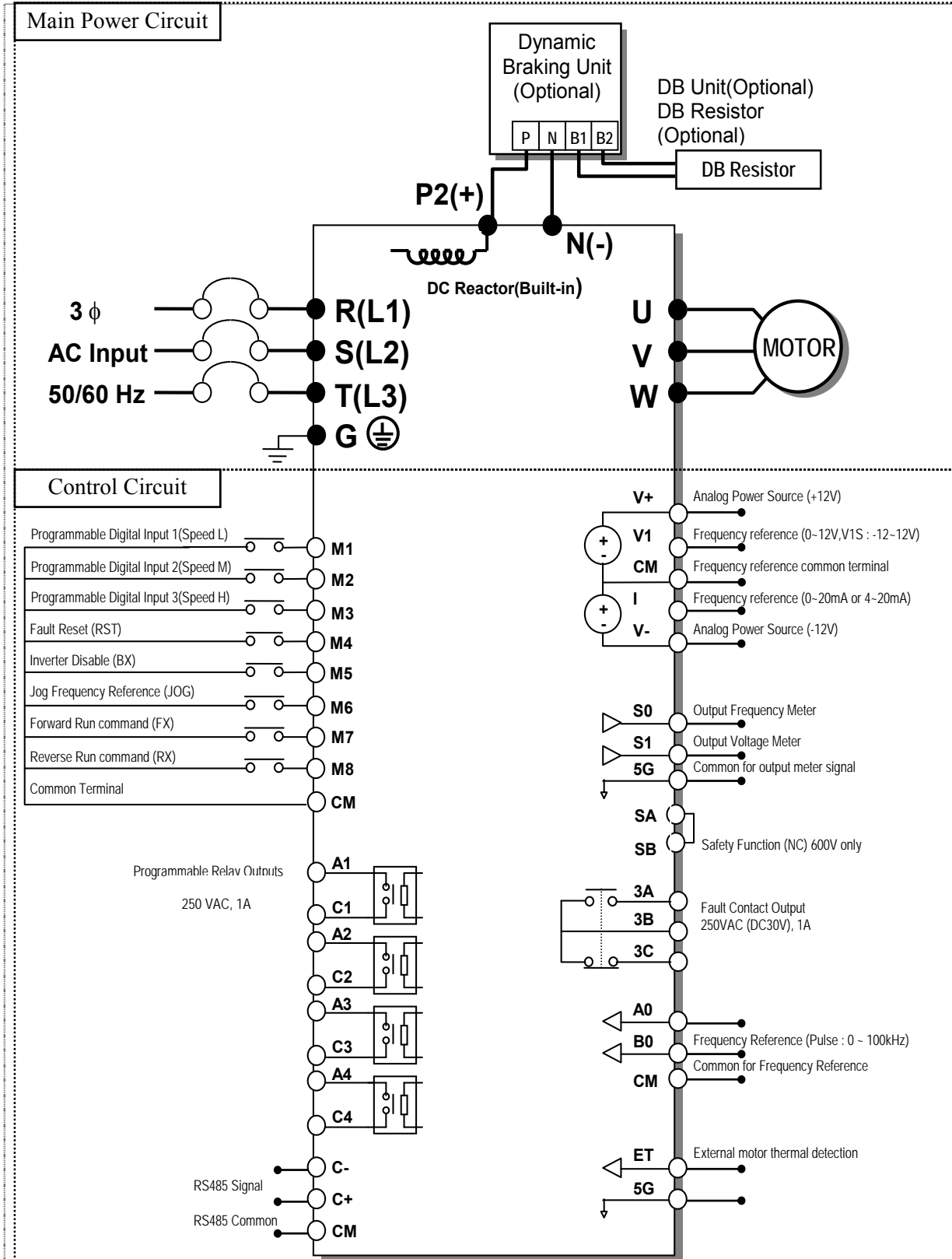

- Note : 1) CM is Common Ground for Analog Input 5G is Common Ground for Analog Output.  
 2) Use terminal V1 for (0-12V input) or V1S (-12 ~ 12V input).  
 3) DC Reactor is built in the inverters for 150~400HP (110~280kW).

## Chapter 3 - Installation

### 4) Power Terminals:

#### Screw Terminals

7.5 ~ 40 HP (230V/460V/575V)

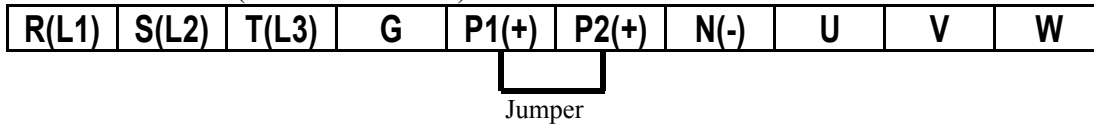

#### Bus Bar Terminals

50 ~ 125 HP (460V/575V) / 500 ~ 700 HP (460V)

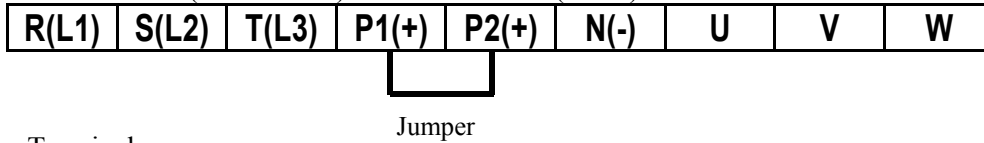

#### Bus Bar Terminals

150 ~ 400 HP (460V)

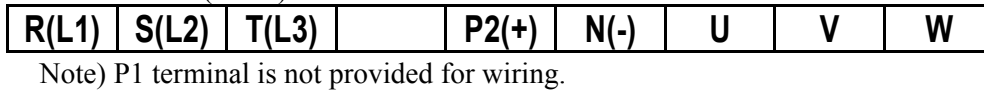

Symbol	Description
R(L1), S(L2), T(L3)	AC Line Voltage Input
G	Earth Ground
P1(+), P2(+)	External DC Reactor (P1-P2) Connection Terminals (Jumper must be removed).
P2(+), N(-)	DB Unit (P2-N) Connection Terminals
U, V, W	3 Phase Power Output Terminals to Motor

5) Control circuit terminal

7.5 ~ 40 HP (230V/460V/575V)

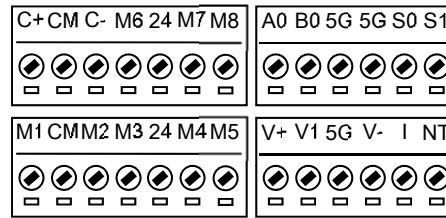
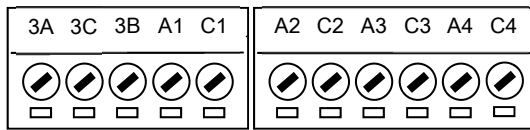
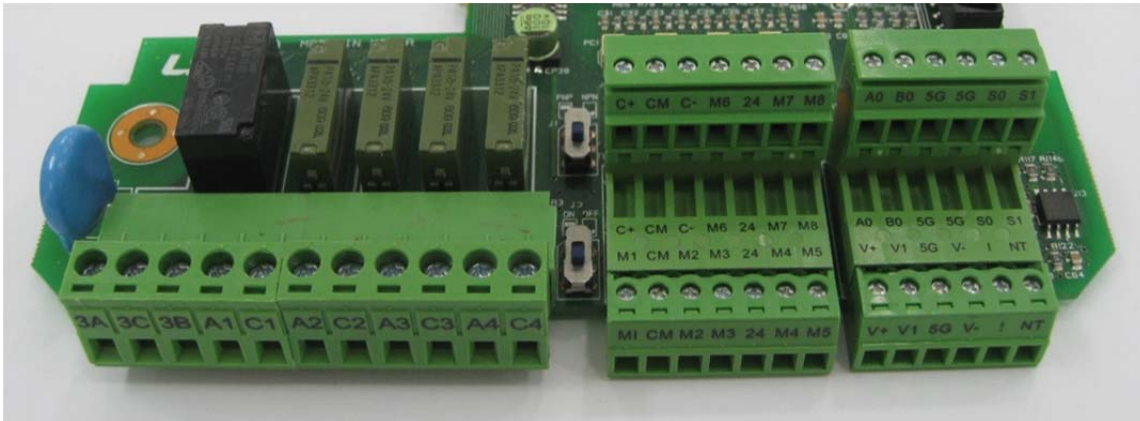

50 ~ 700 HP (460V), 50 ~ 150 HP (575V)

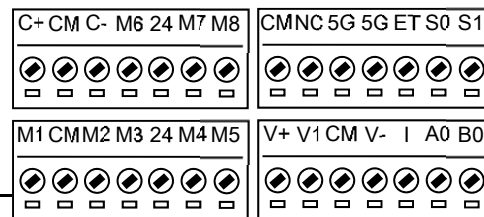
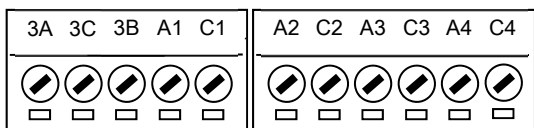
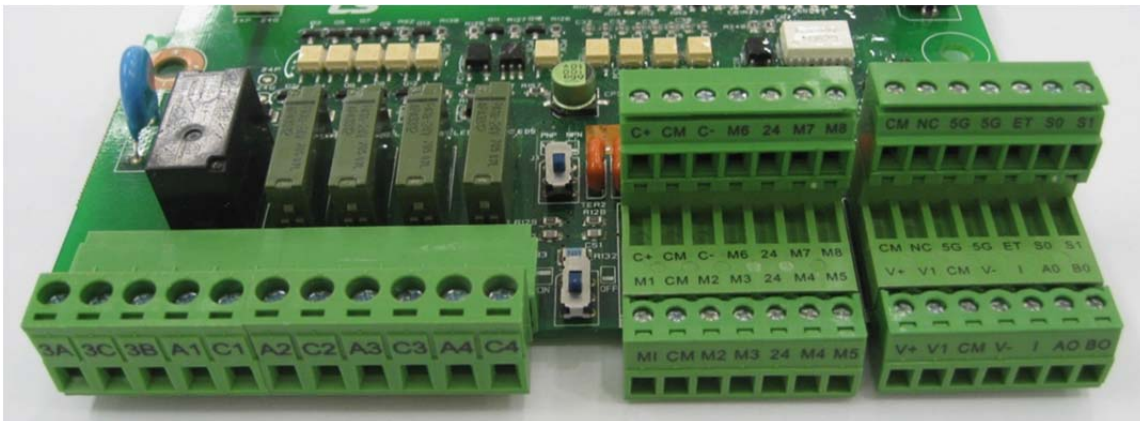

## Chapter 3 - Installation

Type	Symbol	Name	Description
Input signal	Digital Inputs Functions (defaults) Additional Functions (I/O-20 ~ I/O-27)	M1, M2, M3	Multi-Function Input 1, 2, 3 Defines Multi-Function Inputs. (Factory setting: Multi-Step Frequency 1, 2, 3)
		FX [M7]	Forward Run Command Forward Run When Closed and Stopped When Open.
		RX [M8]	Reverse Run Command Reverse Run When Closed and Stopped When Open.
		JOG [M6]	Jog Frequency Reference Runs at Jog Frequency when the Jog Signal is ON. The Direction is set by the FX (or RX) Signal. Jog Speed is set with I/O-30.
		BX [M5]	Inverter Disable When the BX Signal is ON the output of the drive is turned off. When the application uses an Electrical Brake to Stop, BX can be used to turn off the output signal when the brake is applied.
		RST [M4]	Fault Reset Used for fault reset.
		CM	Sequence Common (NPN) / 24V Com Common terminal for NPN contact input and also common for an external 24V supply.
		24	Sequence Common (PNP) / Ext. +24VDC supply 24 V terminal for PNP contact input. Can also be used as a 24VDC external power supply (maximum output: +24V, 50mA).
	Analog Frequency Setting	V+, V-	Frequency Setting Power (+12V,-12V) Power supply for Analog Frequency Setting. (maximum output: +12V, 100mA, -12V, 100mA.)
		V1	Frequency Reference (Voltage) Used by a DC 0-12V or -12~ 12 V input to set the Frequency Reference. (Input Resistance 20 K $\Omega$ ).
		I	Frequency Reference (Current) Used by a 0/4-20mA input to set the frequency reference. (Input Resistance 249 $\Omega$ ).
		A0, B0	Frequency setting (Pulse) Used by a pulse input to set the frequency reference.
		5G (7.5~40HP) CM (50~700HP)	Frequency Setting Common Terminal Common terminal for Analog Frequency Reference signals.
	Motor Thermal Detection	NT (7.5 ~ 40HP) ET (50 ~125HP)	External motor thermal detection Motor thermal sensor input. Used to prevent motor from overheating by using a NTC or PTC thermal sensor.
		RS-485/Modbus terminal	C+, C-
	CM		RS-485/Modbus common Common Gnd. Terminal for RS-485/Modbus interface.
	Output signal	Voltage	S0, S1 (5G) Programmable Voltage Output for external monitoring Voltage output for one of the following: Output Frequency, Output Current, Output Voltage, DC Link Voltage, Power (Watts). Default is set to Output Frequency. (Maximum Output Voltage and Output Current are 0-12V and 30mA).
		Contact	3A, 3C, 3B
A1~4, C1~4			Multi-Function Output Relays User defined: Multi-Function Output terminal settings (AC250V, 1A; DC30V, 1A)

### 3.2.2 Wiring Input and Output Power Terminals

#### General Power Wiring Precautions

- 1) The internal circuits of the drive will be damaged if the incoming power is connected and applied to the output terminals (U, V, W). If a drive bypass contactor is used, extreme care must be taken so that input voltage is never applied to the output terminals. An electrical or mechanical interlock of MC1 and MC2 is required for Inverter Bypass Operation.
- 2) Use ring terminals with insulated caps when wiring the input power and motor wiring.
- 3) Do not leave wire fragments inside the drive. Wire fragments can cause drive faults, short circuits, and other malfunctions.
- 4) Motor torque may drop when operating at low frequencies and with a long wire run between drive and motor.
- 5) The cable length between inverter and motor should be less than 100 feet. Due to increased leakage capacitance between cables, overcurrent protective feature may operate or equipment connected to the output side may malfunction. If cable length between drive and motor is greater than 100 ft. see Motor Lead Length Specifications in this section.
- 6) The main power circuit of the drive may produce high frequency noise, and can hinder communication equipment near the drive. Do not run control wires in the same conduit or raceway with power wiring. To reduce noise, install line noise filters on the input and or output side of the drive.
- 7) Power wiring to the motor must have the maximum possible separation from all other power wiring. Do not run output wires in the same conduit as other wiring.
- 8) Cross wires at right angles whenever power and control wiring cross.
- 9) Do not use power factor capacitor, surge arrestors, or RFI filters on the output side of the drive. Doing so may damage the drive or the added components.
- 10) The input phase voltages must be balanced within 2%. Large input phase voltage imbalances can cause significantly imbalanced input currents that can result in excessive heating of the input diodes and the DC bus capacitors.
- 11) Always check whether the LCD keypad is off and the charge lamp for the power terminal is OFF before wiring terminals. The DC bus capacitors may hold high-voltage even after the power is disconnected. Use caution to prevent the possibility of personal injury.

#### Grounding



- 1) The power source must be grounded. **DO NOT USE AN UNGROUNDED** source of supply.
- 2) **DO NOT CONNECT THE DRIVE** to a Corner Grounded Delta source of supply.
- 3) The drive contains high power and high frequency switching devices, leakage current may flow between the drive and ground. Ground the drive to avoid electrical shock.
- 4) Connect only to the dedicated ground terminal of the drive. Do not use the case or the chassis screw for grounding.
- 5) If multiple drives are installed near each other, each must be connected to ground directly. Take care not to form a ground loop between the drives and the grounding location.
- 6) The protective earth conductor must be the first one in being connected and the last one in being disconnected.
- 7) The grounding wire shall comply with all local regulations. As a minimum, the grounding wire should meet the specifications listed below. The grounding wire should be as short as possible and should be connected to a ground point as near as possible to the drive.

Drive Capacity	Grounding Wire Sizes, AWG or kcmil (mm <sup>2</sup> )		
	230V Class	460V Class	600V Class
7.5 ~ 10 HP	10 (5.5)	12 (3.5)	14 (2.5)
15 ~ 20 HP	6 (14)	8 (8)	12 (3.5)
25 ~ 40 HP	4 (22)	6 (14)	8 (8)
50 ~ 75 HP	-	4 (22)	6 (14)
100 ~ 125 HP	-	2 (38)	4 (22)
150 ~ 200 HP	-	1/0 (60)	2 (38)
250 ~ 400 HP	-	4/0 (100)	1/0 (60)
500 ~ 600 HP	-	300 (150)	-
700 HP	-	400 (200)	-

### Use of Isolation Transformers and Line Reactors

In most cases, the SG drive may be directly connected to a power source. However in the following cases a properly sized isolation transformer or a 3% or 5% line reactor should be used to minimize the risk of drive malfunction.

- When the source capacity exceeds ten (10) times the KVA rating of the drive.
- When power factor capacitors are located on the input source supplying the drive.
- When the power source experiences frequent power transients and/or voltage spikes.
- When the power source supplying the SG drive also supplies other large electrical devices such as DC drives that contain rectifiers or other switching devices.
- When the drive is powered from an ungrounded (floating) Delta connected source. In this case, establish a grounded secondary. A drive isolation transformer utilizing a grounded (solid or resistance grounded) secondary should be used. Other means of establishing a ground may be used.

### Motor Lead Length Specifications

Excessive motor lead lengths may adversely affect the performance of the motor. The voltage of the pulses at the motor terminals can be almost double the input voltage of the drive. This in turn can cause additional stress on the motor insulation and shorten the life of the motor. The motor manufacturer should be consulted regarding the specifications of the motor insulation.

A filter may be required to be added to the output of the drive depending on the lead lengths from the drive to the motor. Contact Benschaw for assistance with selecting the appropriate filter. See the table below.

PWM Carrier Frequency	Motor Lead Length	Type of Filter
Default Frequency or lower	50 ft. to 300 ft.	1.5% or 3% Load Reactor
	300 ft. to 1500 ft.	LRC Filter (dV/dT)
	>1500 ft.	Sine Wave Filter

If an output filter is used it is recommended that the output filter is wired as follows:

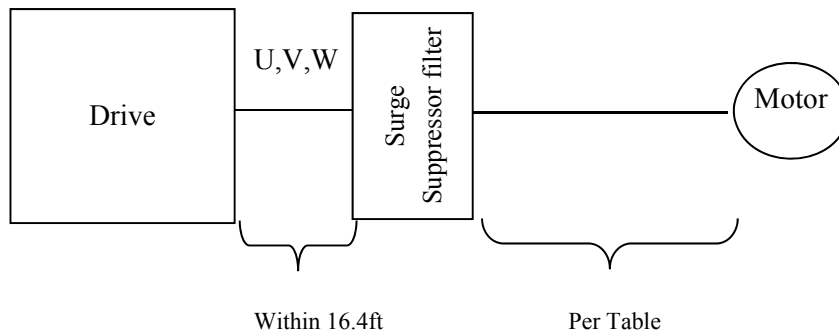

- Wiring distance from drive output to filter input should not exceed 5 meters (16.4 feet).
- Wiring distance from filter to motor should not exceed the distance in the preceding table.

### 3.2.3 Interference Suppression Measures

Electrical and electronic devices are capable of influencing or disturbing each other through their connection cables or other intended and unintended metallic connections. Interference suppression measures (electromagnetic compatibility) consist of two elements: raising interference resistance and suppressing interference emission.

Correct installation of the drive in conjunction with local interference suppression measures has a crucial effect on minimizing or suppressing mutual interference.

The following guidelines assume a power source that is not already contaminated by high frequency interference. Other measures may be necessary to reduce or suppress interference if the power source is already contaminated. Refer to Appendix C for more information.

- When dealing with RFI (radio frequency interference), the surface area of the conductors is a more critical consideration than its cross sectional area. Since high frequency interference currents tend to stay towards the outer surface (skin effect), braided copper tapes of equal cross section should be used.
- A central grounding (or earthing) point should be used for interference suppression. Route the ground cables radially from this point (star connection). Avoid making any ground loops that may lead to increased interference. The drive and all components used for interference suppression, particularly the shield of the motor cable, should be connected over as large a surface area as possible when connecting it to ground. Remove the paint from contact surfaces if necessary to ensure a good electrical connection.
- Take care not to damage the shield's cross section and verify the continuity of the shield when splicing wires. Splices raise the RF resistance of the shield and can cause RF to radiate rather than continue in the shield. Shields, particularly those on control cables, must not be routed through pin contacts (pluggable connectors). When shielded cables must pass through a plug connection, use the metallic hand guard of the plug for the continuation of the shield. It is strongly recommended that the shield be uninterrupted whenever possible.

## Chapter 3 - Installation

---

- Use a shielded motor cable that is grounded over a large surface area at both ends. The shield on this cable should be uninterrupted. If a shielded motor cable cannot be used, the unshielded motor lines should be laid in a metal conduit or duct which is uninterrupted and grounded at both ends.

When selecting shielded cable for use as motor leads it is important to select a cable that is designed for operation at the frequencies and power levels involved with a variable frequency drive. Improper selection of motor cables can cause high potential to exist on the shield. This could cause damage to the drive or other equipment and can pose a safety hazard.

Many cable manufactures have shielded drive cable available. The following cables are acceptable for this purpose: OLFlex Series 150CY, 110CY, 110CS, 100CY, 100CS, and 540CP. Siemens CordaflexSM is also acceptable. Some of these cables are VDE-approved only; others carry VDE, UL, CSA, or a combination of these ratings. Be sure to confirm that the cables meet the appropriate local regulatory requirements.

OLFlex cables are available from OLFlex Wire & Cable, 30 Plymouth Street, Fairfield NJ 07004, 800-774-3539

Cordaflex cables are available from Siemens Energy and Automation, Inc., Power Cables, 3333 State Bridge Road, Atlanta GA 30202, 800-777-3539

- If the installation requires the use of an output reactor, the reactor, as with a line filter, should be placed as close as possible to the drive.
- Low voltage control wires longer than 1 meter (3ft) must use shielded cable and the shield must be terminated at the proper CM connection. Note that the connection to the CM rather than earth ground is allowed because the RSi SG drive has isolated control inputs. If the signal run exceeds 9 meters (30ft), a 0-20mA or 4-20mA signal should be used as it will have better noise immunity than a low-level voltage signal.
- Other loads connected to the power source may produce voltage transients (spikes) that may interfere with or damage the drive. Input line reactors or input filters can be used to protect the drive from these transients.
- If the drive is operated from switchgear devices or is in close proximity to switchgear devices (in a common cabinet), the following procedures are recommended as a precaution to prevent these devices from interfering with the drives operation.
  - Wire the coils of DC devices with freewheeling diodes. The diodes should be placed as close as possible to the physical coil of the device.
  - Wire the coils of AC devices with RC type snubber networks. Place the snubber as close as possible to the physical coil of the device.
- Use shielded cables on all control and monitoring signals.
- Route distribution cables (for example, power and contactor circuits) separately from the drive's control and monitoring signal cables.



### 3.2.4 Terminal Layout

Screw Terminals

7.5 ~ 40 HP (230V/460V/575V)

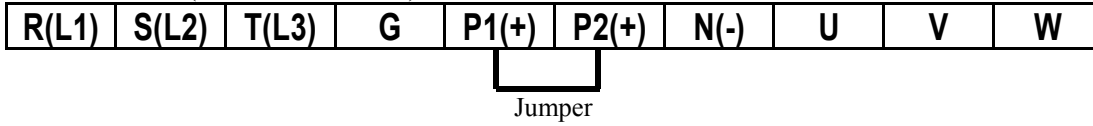

Bus Bar Terminals

50 ~ 125 HP (460V/575V) / 500 ~ 700 HP (460V)

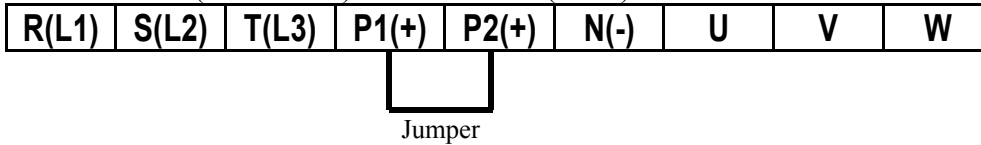

Bus Bar Terminals

150 ~ 400 HP (460V/575V)

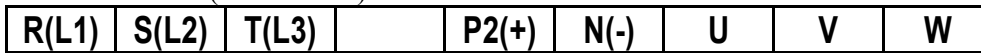

Note) P1 terminal is not provided for wiring.

#### Power and Motor Connection Example (7.5~40 HP drives)

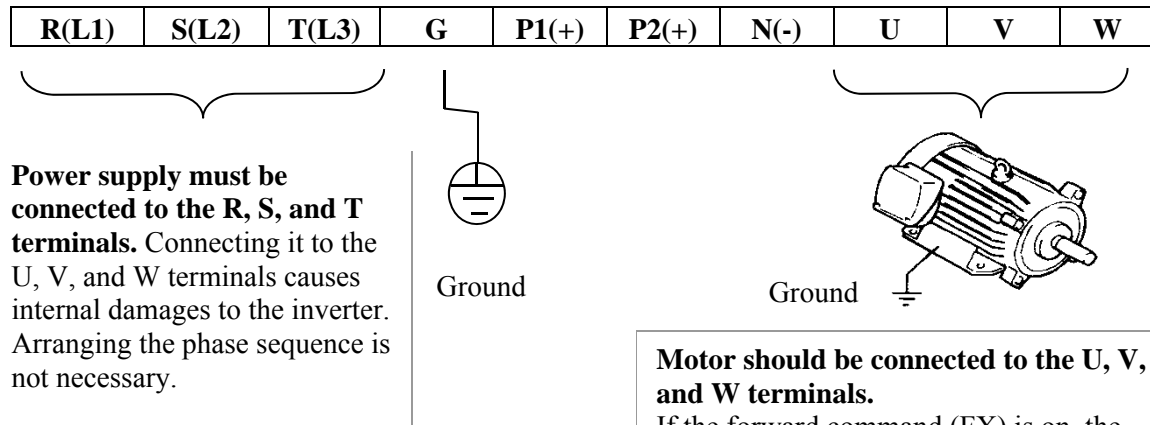

3.2.5 Wire Sizing and Terminal Lugs

The input power and motor cables must be of the appropriate type and dimensioned according to applicable national and local (NEC, etc.) regulations to carry the rated current of the drive. It is recommended that the cables be at least the size listed below in the following table.

Drive capacity	Terminal screw size	Screw torque <sup>1)</sup> N·m / lb-in	Wire <sup>2)</sup>				
			mm <sup>2</sup>		AWG or kcmil		
			R, S, T	U, V, W	R, S, T	U, V, W	
230V	7.5HP	M4	1.2/ 10.6	5.5	5.5	10	10
	10HP	M5	3.1/ 27.6	8	8	8	8
	15HP	M5	3.1/ 27.6	14	14	6	6
	20HP	M6	3.7/ 33.2	22	22	4	4
	25HP	M6	3.7/ 33.2	38	38	2	2
	30HP	M8	8.9/ 79.7	38	38	2	2
	40HP	M8	8.9/ 79.7	60	60	1/0	1/0
460V	7.5HP	M4	1.2/ 10.6	3.5	3.5	12	12
	10HP	M5	1.2/ 10.6	3.5	3.5	12	12
	15HP	M5	1.2/ 10.6	5.5	5.5	10	10
	20HP	M6	3.7/ 33.2	8	8	8	8
	25HP	M6	3.7/ 33.2	14	14	6	6
	30 ~ 40HP	M8	8.9/ 79.7	22	22	4	4
	50 ~ 75HP	M8	8.9/ 79.7	38	38	2	2
	100 ~ 125HP	M10	11.9/ 105.9	60	60	1/0	1/0
	150 ~ 200HP	M12	20.9/ 186.6	100	100	4/0	4/0
	250HP	M12	20.9/ 186.6	150	150	300	300
	350HP	M12	20.9/ 186.6	200	200	400	400
	400HP	M12	20.9/ 186.6	250	250	500	500
	500HP	M12	20.9/ 186.6	325	325	700	700
600HP	M12	20.9/ 186.6	2 × 200	2 × 200	2 × 400	2 × 400	
700HP	M12	20.9/ 186.6	2 × 250	2 × 250	2 × 500	2 × 500	
600V	7.5HP	M4	0.6/ 5.2	3.5	3.5	12	12
	10HP	M4	0.6/ 5.2	3.5	3.5	12	12
	15HP	M4	0.6/ 5.2	5.5	5.5	10	10
	20HP	M6	3.7/ 33.2	8	8	8	8
	25HP	M6	3.7/ 33.2	14	14	6	6
	30 ~ 40HP	M8	8.9/ 79.7	22	22	4	4
	50 ~ 75HP	M8	8.9/ 79.7	38	38	2	2
	100 ~ 125HP	M10	11.9/ 105.9	60	60	1/0	1/0
	150 ~ 400HP	M12	20.9/ 186.6	100	100	4/0	4/0

1) Apply the rated torque to terminal screws. Loose terminal screws can cause a short circuit or other malfunction. Over tightening the terminal screws/bolts may permanently damage the terminals.

2) Use copper (Cu) wires only with 600V, 75°C ratings. For 10~15HP 240V drives, R, S, T and U, V, W terminals are only for use with insulated ring type connectors.

### 3.2.6 Control Circuit Wiring

(1) Wiring Precautions

CM and 5G terminals are isolated from each other.

Digital Input Terminals are rated 24 VDC. Do not apply 120 Vac directly to control circuit input terminals.

Use shielded wires or twisted wires for all control circuit wiring, and separate these wires from the main power circuits and other high voltage circuits (such as 120V relay circuits).

It is recommended to use wire sizes of 28 AWG to 16 AWG for TER1 and TER2 control terminals and 22 AWG to 14 AWG for TER3 and TER4 control terminals.

(2) Terminal layout

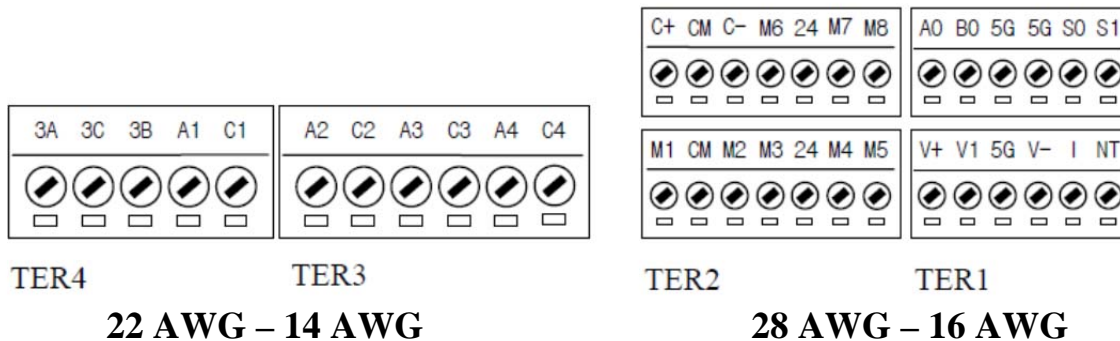

## 5G and CM

**NOTE:** When using analog input terminals (V1, I) for speed reference, notice the difference between TER 1 ground connections. For 40 HP and below, use the 5G terminal as the analog ground. For 50 HP and above, use the CM terminal as the analog ground.

(3) Control circuit operation

RSI-SG provides NPN/PNP modes for activating the input terminals on the control board. Each connection method is described below.

**Method 1: NPN mode, Mx – CM**

**NPN mode:** when J1 switch is set to NPN mode (downward), use Mx to CM for connection of an external contact (switch, relay or transistor). With contact closed, the control board input terminal is activated (turned ON) using the internal 24V power supply.

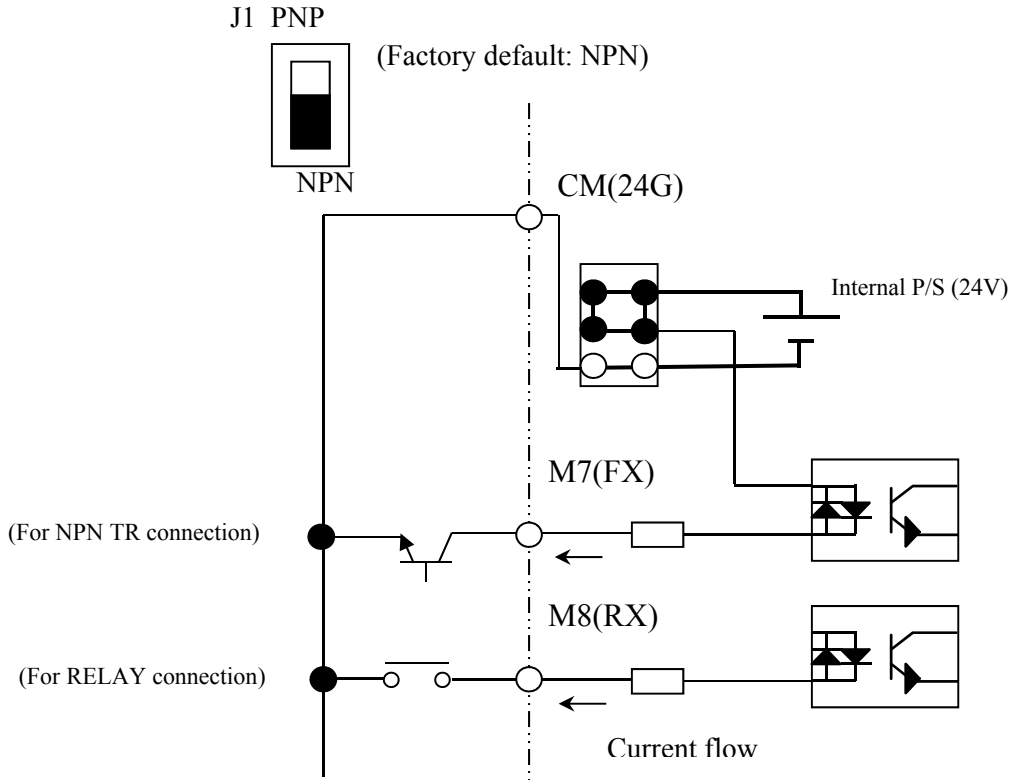

**Method 2: PNP mode, 24V – Mx**

**PNP mode (Internal P/S used):** when J1 switch is set to PNP mode (upward), use 24V to Mx for connection of an external contact (switch, relay or transistor). With contact closed, the control board input terminal is activated (turned ON) using the internal 24V power supply.

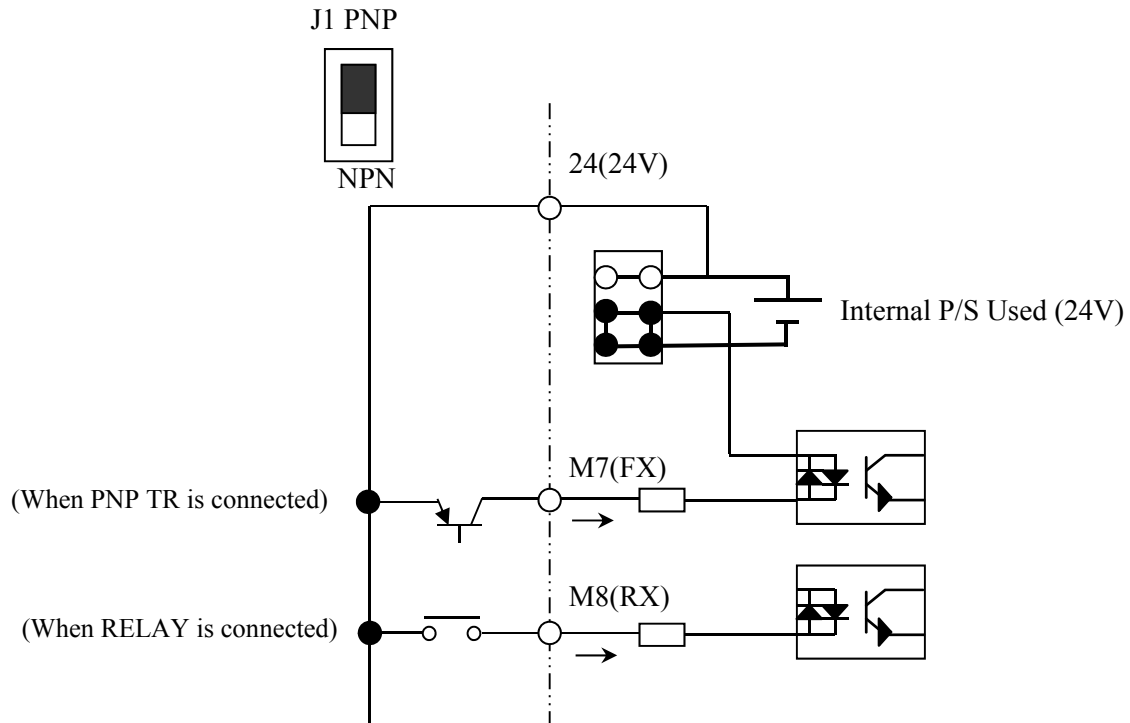

**Method 3: External 24V – Mx**

**PNP mode (External P/S used):** when J1 switch is set to PNP mode (upward), use an external 24V to Mx for connection of a contact (switch, relay or transistor). With contact closed, the control board input terminal is activated (turned ON). Make an additional connection between the negative of the external power supply and the CM terminal.

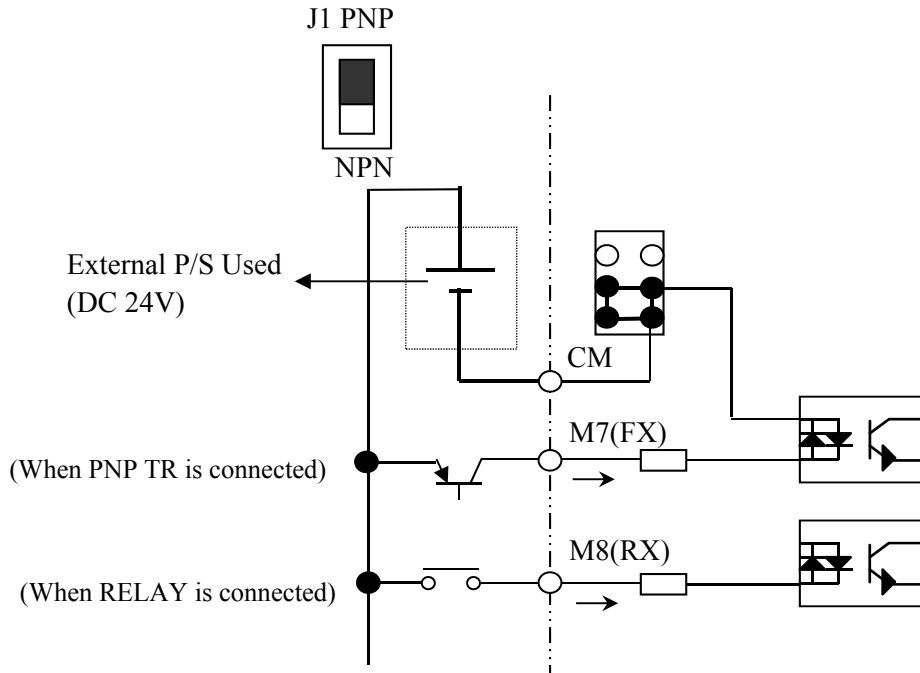

**3.2.7 RS-485/Modbus-RTU Circuit Wiring**

C+	CM	C-	M6	24	M7	M8
M1	CM	M2	M3	24	M4	M5

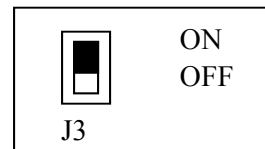

Use C+ (Modbus signal High) and C- (Modbus signal LOW) in TER 2. Turn the switch J3 ON (Upward) to connect the termination resistor (120 ohm) if required. J3 switch is on the left side of the TER2.

Item	Specification
Transmission type	Bus method, Multi drop Link System
Applicable drive	RSi-SG series
Number of drives	Max.31
Transmission distance	Within 1200 m (3937ft) Max. 700 m (2290ft) recommended
Recommendable cable	0.75mm <sup>2</sup> (18AWG), Shield Type Twisted-pair Wire
Installation	C+, C-, CM terminals on the control terminal block
Isolation	RS-485 port isolated from the drive power supply.

### 3.2.8 Keypad Wiring

The keypad connects to the control board at the keypad connector (CN2).

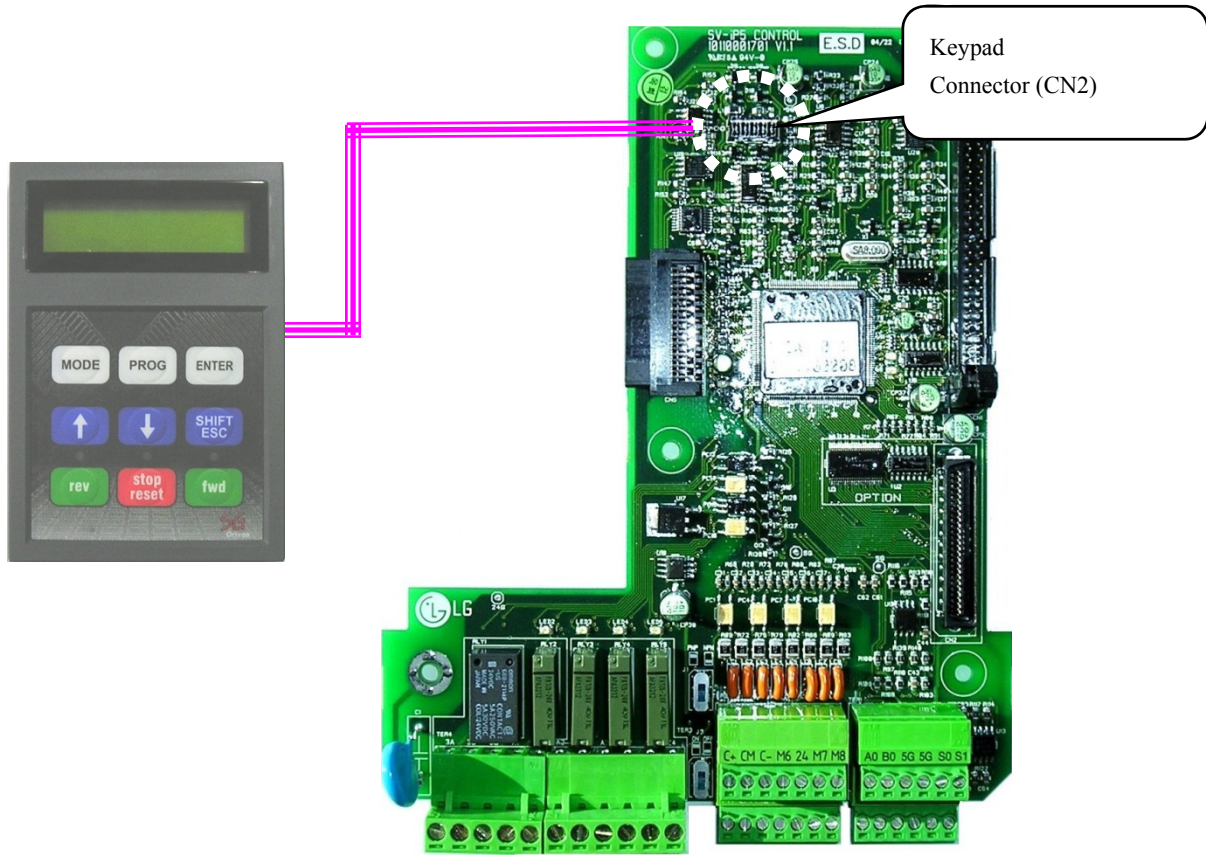

■ Notes :



## Chapter 4. Operation

### 4.1 Keypad Programming

#### 4.1.1 LCD Keypad

The RSi SG drive LCD keypad can display up to 32 alphanumeric characters. Drive status can be checked directly from the display and parameter values can be adjusted. The following is an illustration of the keypad.

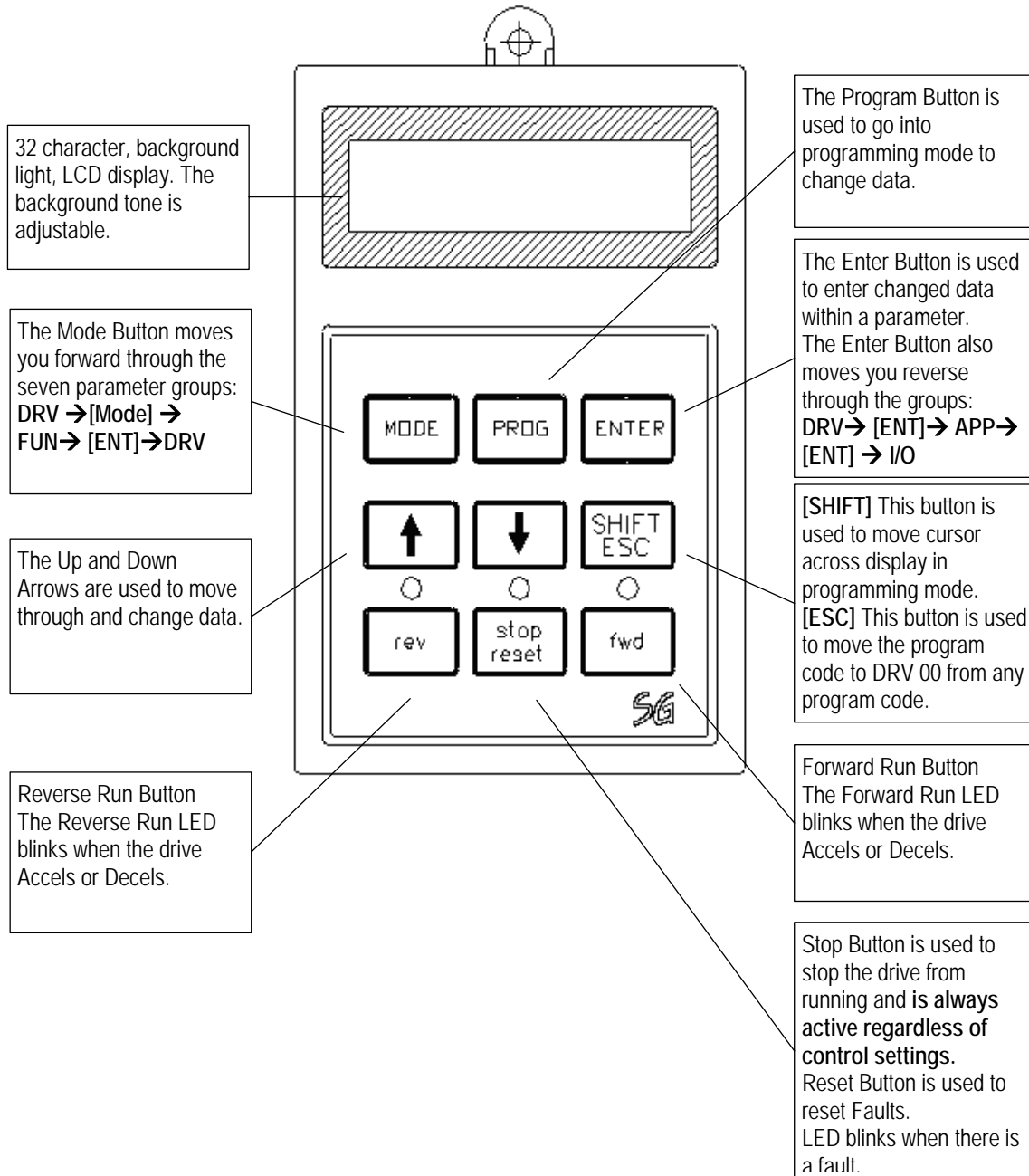

4.1.2 Detailed Description

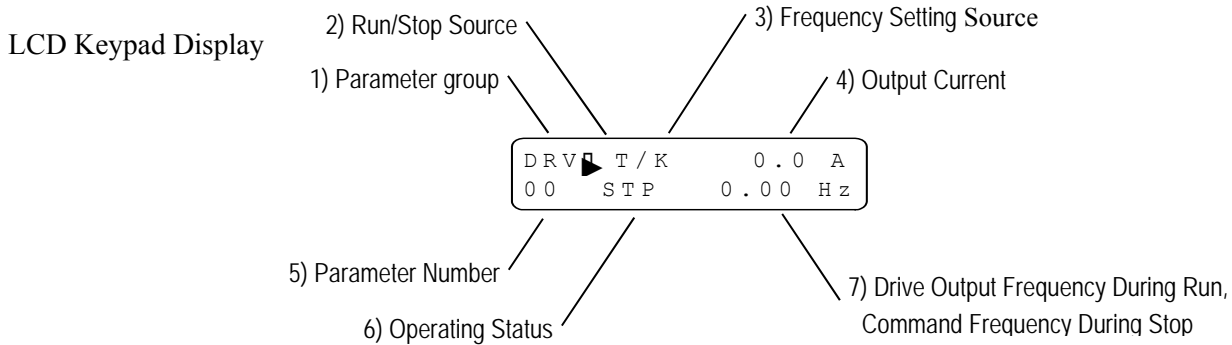

Displays	Description
1) Parameter Group	Displays the parameter group. There are DRV, FUN, AFN, I/O, and APP groups.
2) Run/Stop Source	Displays the control source for the drives run command. <b>K</b> : Run/Stop using FWD, REV buttons on keypad <b>T</b> : Run/Stop using control terminal input FX, RX <b>R</b> : Run/Stop using Modbus <b>O</b> : Run/Stop via option board
3) Frequency Setting Source	Displays the source of the drive's frequency command. <b>K</b> : Frequency setting using keypad <b>V</b> : Frequency setting using V1 (0 ~12V) or V1 + I terminal <b>W</b> : Frequency setting using V1S (-12~ 12V) <b>I</b> : Frequency setting using I (4 ~ 20mA) terminal <b>P</b> : Frequency setting using Pulse input <b>R</b> : Frequency setting using RS-485, Modbus-RTU <b>U</b> : Up terminal input when Up/Down operation is selected <b>D</b> : Down terminal input when Up/Down operation is selected <b>S</b> : Stop status when Up/Down operation is selected <b>O</b> : Frequency setting via Communication Option board <b>J</b> : Jog terminal input <b>1 ~ 15</b> : Step frequency operation (except Jog)
4) Output Current	Displays the Output Current during operation.
5) Parameter Number	Displays the parameter number. Use the ▲(Up), ▼(Down) key to move through the parameters.
6) Operating Status	Displays the operation information. <b>STP</b> : Stop Status <b>FWD</b> : During Forward operation <b>REV</b> : During Reverse operation <b>DCB</b> : During DC Braking <b>LOV</b> : Loss of Analog Frequency Reference (V1: 0~12V, -12~12V) <b>LOI</b> : Loss of Analog Frequency Reference (I: 4~20mA) <b>LOA</b> : Loss of Pulsed Reference Input <b>LOR</b> : Loss of Reference from Communications Option Board (Communication network fault) <b>Over Lap (flashing)</b> : More than one digital input is programmed to the same function.
7) Drive Output Frequency/ Command Frequency	Displays the Output Frequency during run. Displays the Command Frequency during stop.

### 4.1.3 Parameter Setting and Adjustment

- 1) Press [**MODE**] key until the desired parameter group is displayed.
- 2) Press [**▲**] or [**▼**] keys to move to the desired parameter number. If you know the desired parameter number, you can program the parameter number within each parameter group in “Jump code”, except DRV group.
- 3) Press [**PROG**] key to go into the programming mode, the cursor starts blinking.
- 4) Press [**SHIFT/ESC**] key to move the cursor to the desired digit.
- 5) Press [**▲**] or [**▼**] keys to change the data.
- 6) Press [**ENTER**] key to enter the data. The cursor stops blinking.

**Note:** Certain parameters cannot be changed when the drive is running or AFN-94 [Parameter Lock] is activated. (Refer to the parameter list, Chapter 5 for details).

EX) Changing Accel time from 10 sec to 15 sec

- 1) LCD keypad

DRV ▶ Acc. Time
01    _10.0 sec

Move to the desired parameter to change.

DRV ▶ Acc. Time
01    █10.0 sec

Press the [**PROG**] key.  
A Cursor (█) will appear.

DRV ▶ Acc. Time
01    _10.0 sec

Use the [**SHIFT**] key to move the cursor.

DRV ▶ Acc. Time
01    _15.0 sec

Change the data using [**▲**], [**▼**] keys.

DRV ▶ Acc. Time
01    _15.0 sec

Press the [**ENTER**] key to save the value into memory.  
The Cursor will disappear.

### 4.1.4 Parameter Groups

The SG series drive has 5 parameter groups separated according to their applications as indicated in the following table.

<b>Parameter Group</b>	<b>LCD Keypad</b>	<b>Description</b>
Drive Group	DRV	Command Frequency, Accel/Decel Time etc. Basic function Parameters
Function Group	FUN	Max. Frequency, Amount of Torque Boost etc. Parameters related to basic functions
Advance Function Group	AFN	Frequency Jumps, Max/Min Frequency Limit etc. Basic Application Parameters
Input / Output Group	I/O	Multi-Function Terminal Setting, Auto Operation etc. Parameters needed for Sequence Operation
Application Group	APP	PID, MMC (Multi-Motor Control), 2 <sup>nd</sup> motor operation etc. Parameters related to Application function

Refer to the parameter descriptions (Chapter 6) for detailed descriptions of each parameter.

**Parameter Navigation:** Pressing the [SHIFT] key at any time moves directly to the main screen of the DRV group. Pressing the [MODE] key moves forward through the groups. Pressing the [ENTER] key moves reverse through the groups.

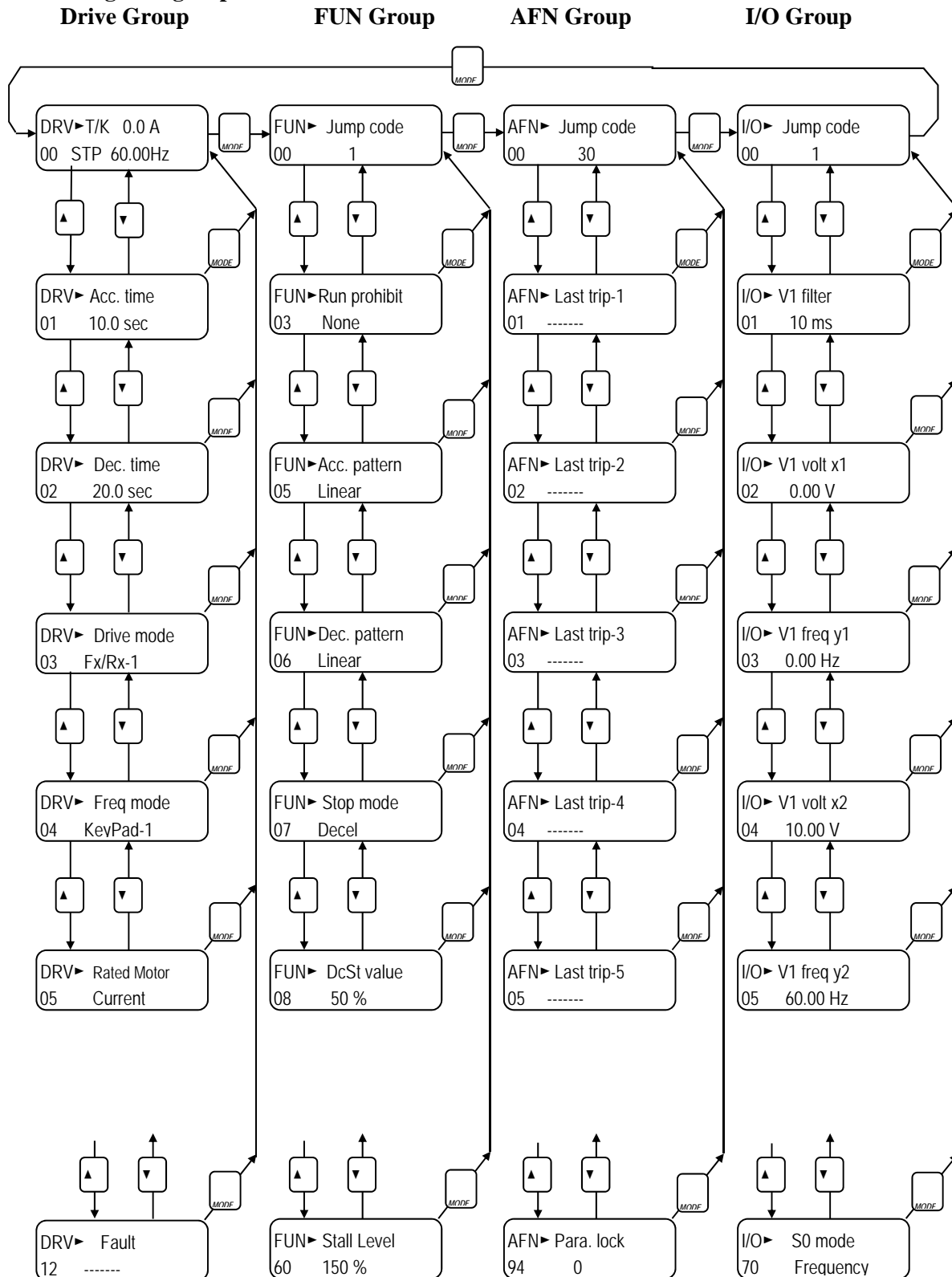

**Note:** Actual parameters may vary due to software versions.

### 4.1.5 Easy Start Operation

Easy Start Operation is activated by pressing STOP key on the Keypad for 2~3 seconds and the drive begins operation via Keypad (FWD/REV RUN/STOP). **Drive mode is preset to V/F and reference frequency to JOG (default 10 Hz).** To exit Easy Start, press the Shift/Esc key.

### 4.1.6 Quickstart 1: Start / Stop and Speed Control via the Keypad

To operate the drive from the keypad, set the following parameters:

**DRV-03** [Drive Mode (Run/Stop method)] = **0 (Keypad)**

**DRV-04** [Frequency Mode (Freq. setting method)] = **0 (Keypad-1)**

1) Check the LCD display when power is applied. The display should read:



DRV>K/K 0.0 A  
00 STP 0.00Hz

2) Push the **PROGRAM** key.

3) Enter the desired frequency by using the arrow keys.

4) Press the **ENTER** key to store the value into memory.

5) Press the **FWD** key to start the drive in the forward direction. The output frequency and output current are displayed.

6) Press the **STOP/RESET** key. The motor will decelerate to a stop. The set frequency will be displayed.

4.1.7 Quickstart 2: Two Wire Start and Control via Speed Potentiometer

**Description:** The following example shows how to configure the drive to operate from a speed potentiometer and a remote two wire start command. **If a three-wire start/stop circuit is required refer to I/O 20 – 29. One of the inputs can be configured to 3-wire.**

[Wiring]

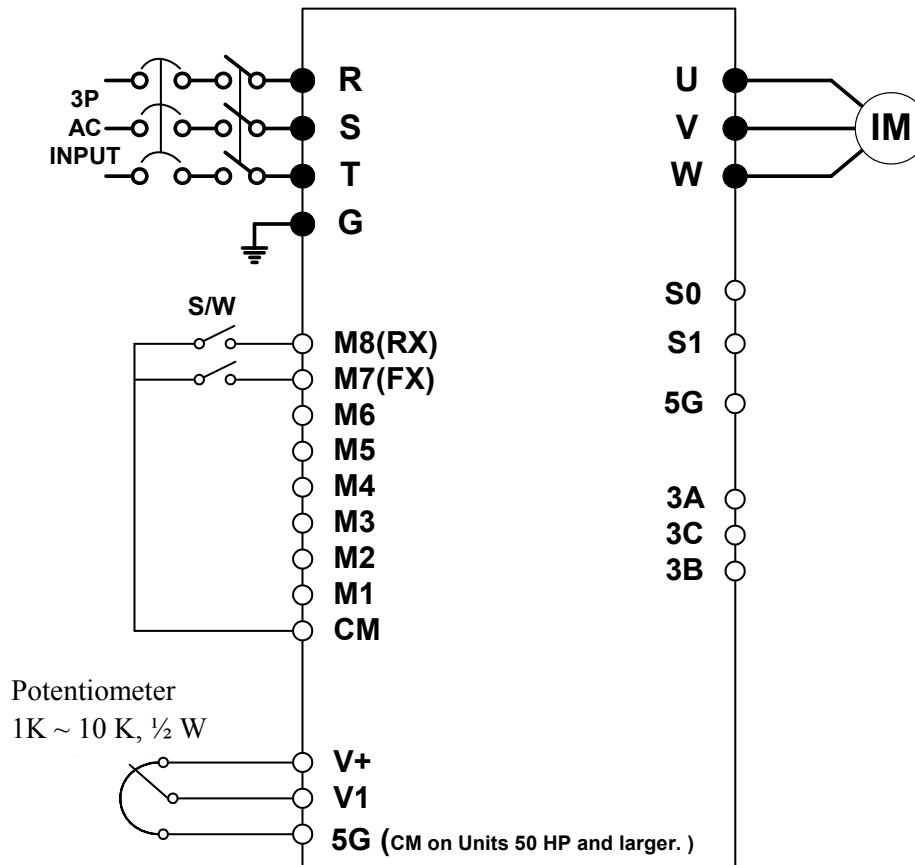

Step	Parameter Name	Parameter Number	Description
1	Drive Mode	DRV-03	Set it to Fx/Rx-1.
2	Frequency Mode	DRV-04	Set it to V1 Analog input.
3	Freq. command setting	DRV-00	Set the frequency command to desired speed via the potentiometer.

By closing M7 – CM the drive will start in the forward direction.  
 By closing M8 – CM the drive will start in the reverse direction.

4.1.8 Quickstart 3: Two Wire Start and Control via 4-20mA Analog Input

**Description:** The following example shows how to configure the drive to operate from a 4-20mA analog input and a remote two wire start command. **If a three-wire start/stop circuit is required refer to I/O 20 – 29. One of the inputs can be configured to 3-wire.**

[Wiring]

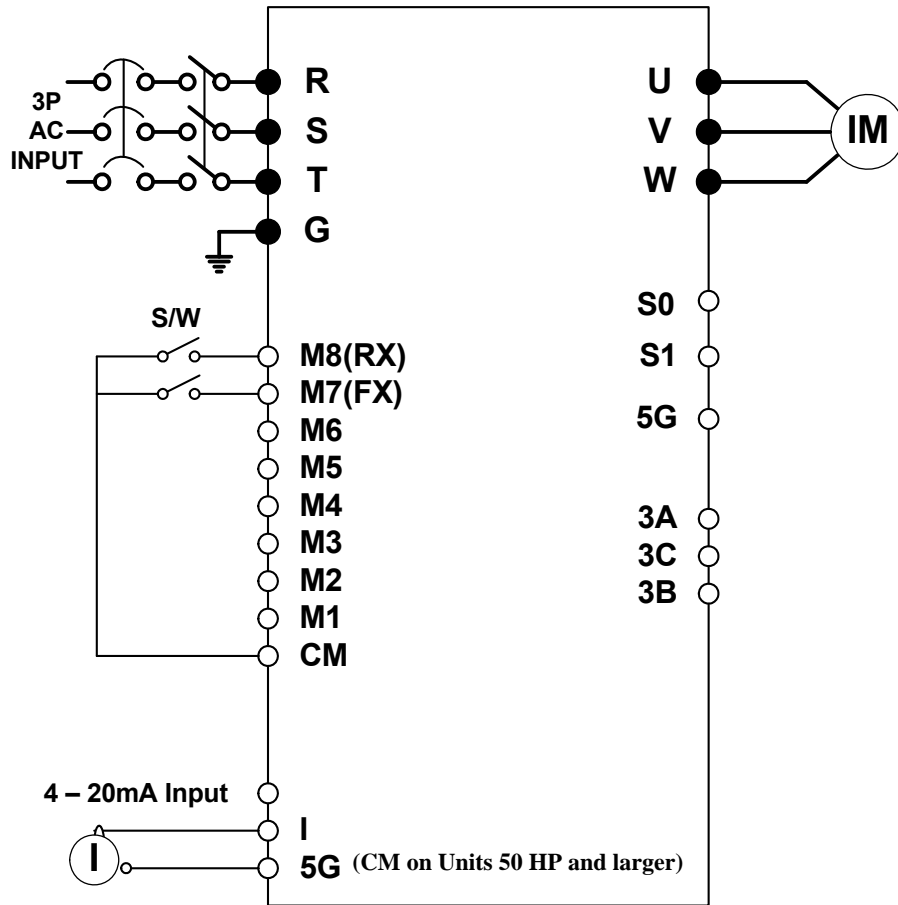

Step	Parameter Name	Parameter Number	Description
1	Drive Mode	DRV-03	Set it to Fx/Rx-1.
2	Frequency Mode	DRV-04	Set it to I Analog input.
3	Freq. command setting	DRV-00	Set the frequency command to desired speed via the analog input.

By closing M7 – CM the drive will start in the forward direction.  
 By closing M8 – CM the drive will start in the reverse direction.



■ Notes :



## Chapter 5. Parameter List

### 5.1 DRV (Drive Group) Parameter List

[DRV Group]

PARAM	Description	LCD Keypad Display	Setting Range	Factory Default	Adj. During Run	Page	
DRV-00 (Notes 1 & 2)	Main Display	DRV>K/K 0.0 A 00 STP 0.50Hz.	0 - (FUN-30) Hz.	0	Yes	6-1	
DRV-01	Acceleration Time	7.5~125HP	Acc. time	0 - 6000 secs.	20	Yes	6-1
		150~700HP	Acc. time	0 - 6000 secs.	60		
DRV-02	Deceleration Time	7.5~125HP	Dec. time	0 - 6000 secs.	30	Yes	6-1
		150~700HP	Dec. time	0 - 6000 secs.	90		
DRV-03	Drive Mode (Run/Stop Method)	Drive mode	Keypad Fx/Rx-1 Fx/Rx-2 Int. 485	Fx/Rx-1	No	6-1	
DRV-04	Frequency Mode (Frequency setting method)	Freq mode	Keypad-1 Keypad-2 V1 V1S I V1+I Pulse Int. 485 Ext. PID	Keypad-1	No	6-2	
DRV-05	Rated Motor Current	Rated-Curr	1.0 - 999.9 Amps	Model Dependent	No	6-2	
DRV-06	Electronic Thermal Selection	ETH select	No, Yes	Yes	Yes	6-3	
DRV-07	Electronic Thermal Level for 1 Minute	ETH 1 min	DRV-08 - 200%	130	Yes	6-3	
DRV-08	Electronic Thermal Level Continuous	ETH cont	50 - DRV-07 %	100	Yes	6-3	
DRV-09	Characteristic Selection (Motor Type)	Motor type	Self-cool Forced-cool	Self-cool	Yes	6-3	
DRV-10	Output Current	Current	Amps	Amps	View Only	6-4	
DRV-11	DC Link Voltage	DC link Vtg	Volts	Volts	View Only	6-4	
DRV-12	User Display Selection	User disp	Voltage kiloWatts	Volts	View Only	6-4	
DRV-13	Present Trip Display	Fault		None	View Only	6-4	
DRV-14	Motor Speed	Speed	rpm	rpm	View Only	6-5	
DRV-15	Target/Output Frequency Display	TAR 0.00 Hz OUT 0.00 Hz	Hz., RPM	Hz.	View Only	6-5	
DRV-16 (Note 3)	Reference/Feedback Frequency Display	REF 0.00 Hz FBK 0.00 Hz	Hz., RPM	Hz.	View Only	6-5	
DRV-17	Hz/Rpm Display	Hz/Rpm Disp	Hz., RPM	Hz.	Yes	6-6	
DRV-18 (Note 3)	PID Parameter	R 0.0 Hz T 0.0 Hz F 0.0 Hz O 0.0 Hz		Hz.	View Only	6-6	
DRV-19	AD Parameter	V1 0 V2 0 V1S 0 I 0			View Only	6-6	
DRV-20 (Note 4)	EXT-PID Parameter	R 0.00% O 0.00% F 0.00% DRV 20			View Only	6-6	
DRV-21 (Note 5)	Step Frequency 1	Step Freq-1	0 - (FUN-30) Hz.	10	Yes	6-6	
DRV-22	Step Frequency 2	Step Freq-2		20	Yes		
DRV-23	Step Frequency 3	Step Freq-3		30	Yes		

## Chapter 5 – Parameter List

PARAM	Description	LCD Keypad Display	Setting Range	Factory Default	Adj. During Run	Page
DRV-24	Output Current	Ia= 0A Ib= 0A Ic= 0A It= 0A			View Only	6-7
DRV-26	Keypad Reference Mode	KeyRefMode	Minimum Spd Last Spd Preset Spd 1 Stop Fault Disable	Disable	Yes	6-7
DRV-27	Current, Phase U	Ia Current, 0.0A			View Only	6-7
DRV-28	Current, Phase V	Ib Current, 0.0A			View Only	6-7
DRV-29	Current, Phase W	Ic Current, 0.0A			View Only	6-7
DRV-30	Current, Ground	Ground Curr, 0.0A			View Only	6-7
DRV-91 (Note 6)	Drive Mode 2 (Run/Stop Method)	Drive mode 2	Keypad Fx/Rx-1 Fx/Rx-2	Fx/Rx-1	No	6-7
DRV-92	Frequency Mode 2 (Frequency Setting Method)	Freq mode 2	Keypad-1 Keypad-2 V1 V1S I V1+I Pulse Int. 485 Ext. PID	Keypad-1	No	6-7

The **gray**-highlighted parameters are hidden parameters and will only appear when the related functions are set.

**Note 1:** To change display from Hz. To RPM, see DRV 17.

**Note 2:** When operating in PI Mode (APP02 set to “yes”), the Set point will be displayed when stopped. The units of the set point are selected using I/O-86. When running, speed is displayed in Hz.

**Note 3:** Only displayed when APP-02 is set to “yes” (PI Mode).

**Note 4:** Only displayed when APP-80 is set to “yes” (Ext. Process PI Mode).

**Note 5:** DRV21 - 23 are only displayed when I/O 20 - 27 are set to “Speed-L, -M, -H”.

**Note 6:** DRV91, 92 are only displayed when I/O 20 - 27 is set to “LOC/REM”.

## 5.2 FUN (Function Group) Parameter List

## [FUN GROUP]

PARAM	Description	LCD Keypad Display	Setting Range	Factory Default	Adj. During Run	Page
FUN-00	Jump Code – Program, a specific parameter #, hit enter to jump to that parameter.	Jump Code	0 - 74	1	Yes	6-9
FUN-01	Run Prevention	Run Prev.	None Forward Prev. Reverse Prev.	None	No	6-9
FUN-02	Acceleration Pattern	Acc. Pattern	Linear S-curve U-curve	Linear	No	6-9
FUN-03	Deceleration Pattern	Dec. pattern	Linear S-curve U-curve	Linear	No	6-9
FUN-04 (Note 7)	Start Curve for S-Curve Accel/Decel Pattern	Start Curve	0 - 100 %	50	No	6-9
FUN-05	End Curve for S-Curve Accel/Decel Pattern	End Curve	0 - 100 %	50	No	
FUN-10	Pre-Heat	Pre-Heat Mode	No, Yes	No	No	6-10
FUN-11 (Note 8)	Pre-Heat Value	Pre Heat Level	1 - 50 %	30	No	
FUN-12	Pre-Heat Duty	Pre Heat Perc	1 - 100 %	100	No	
FUN-20	Start Mode	Start mode	Accel DC-Start Flying-Start	Accel	No	6-11
FUN-21 (Note 9)	Starting DC Injection Braking Time	DcSt time	0 - 60 secs.	0	No	6-11
FUN-22	Starting DC Injection Braking Value	DcSt value	0 - 150 %	50	No	
FUN-23	Stop Mode	Stop mode	Decel DC-brake Free-run Flux-brake	Decel	No	6-12
FUN-24 (Note 10)	DC Injection Braking On-Delay Time	DcBr Dly tim	0.10 - 60.00 secs.	0.10	No	6-13
FUN-25	DC Injection Braking Frequency	DcBr Freq	0.10 - 60.00 Hz.	5.00	No	
FUN-26	DC Injection Braking Time	DcBr time	0 - 60.00 secs.	1.0	No	
FUN-27	DC Injection Braking Value	DcBr value	0 - 200 %	50	No	
FUN-28	Safety Stop	Safety Stop	No, Yes	No	No	6-13
FUN-29	Power Source Frequency	Line Freq 60.00 Hz	40 - 120 Hz.	60.00	No	6-14
FUN-30	Maximum Frequency	Max Freq	40 - 120 Hz.	60.00	No	6-14
FUN-31	Base Frequency	Base Freq	30 - FUN-30 Hz.	60.00	No	6-14
FUN-32	Starting Frequency	Start Freq	0.01 - 10.00 Hz.	0.50	No	6-14
FUN-33	Frequency Limit Selection	Freq limit	No, Yes	No	No	6-15
FUN-34 (Note 11)	Low Limit Frequency	Lim Lo Freq	0 - FUN-35 Hz.	0.50	Yes	6-15
FUN-35	High Limit Frequency	Lim Hi Freq	FUN-34- FUN-30	60.00	No	
FUN-40	Volts/Hz Pattern	V/F pattern	Linear Square User V/F	Linear	No	6-15
FUN-41 (Note 12)	User V/F – Frequency 1	User Freq 1	0 - FUN-30	15.00	No	6-16
FUN-42	User V/F – Voltage 1	User volt 1	0 to 100 %	25	No	
FUN-43	User V/F – Frequency 2	User Freq 2	0 - FUN-30	30.00	No	

## Chapter 5 – Parameter List

PARAM	Description	LCD Keypad Display	Setting Range	Factory Default	Adj. During Run	Page
FUN-44	User V/F – Voltage 2	User volt 2	0 - 100 %	50	No	
FUN-45	User V/F – Frequency 3	User Freq 3	0 - FUN-30	45.00	No	
FUN-46	User V/F – Voltage 3	User volt 3	0 - 100 %	75	No	6-16
FUN-47	User V/F – Frequency 4	User Freq 4	0 - FUN-30	60.00	No	
FUN-48	User V/F – Voltage 4	User volt 4	0 - 100 %	100	No	
FUN-49	AC Input voltage Adjustment	100 %	73 - 115 %	100	No	
FUN-50	Motor Rated Voltage (Model Dependant)	Motor Volt	0 - 600 V	230 V 460 V 575 V	No	6-16
FUN-51	Energy Save	Energy save	None Manual Auto	None	No	6-17
FUN-52 (Note 13)	ManualSave %	Manual save%	0 - 30 %	0	Yes	
FUN-54	Integrating Watt Meter	KiloWattHour OM 0.0kWh	9999999.9 kWh	0	View Only	6-17
FUN-55	Inverter Temperature	Inv. Temp.	0 - 160 deg. Cel.		View Only	6-17
FUN-56	Motor Temperature	Motor Temp.	0 - 160 deg. Cel.		View Only	6-18
FUN-57	No Motor Selection	No Motor Sel	No, Yes	No	No	6-18
FUN-58 (Note 14)	Trip Current Level	No Motor Level	5 - 100 %	5	No	6-18
FUN-59	Trip Time Setting	No Motor Time	0.5 - 10.0 secs.	3.0	No	6-18
FUN-64	Overload Warning Level	OL level	30 - 110 %	110	Yes	6-18
FUN-65	Overload Warning Time	OL time	0 - 30 secs.	10.0	Yes	6-18
FUN-66	Overload Trip Selection	OLT select	No, Yes	No	Yes	6-19
FUN-67 (Note 15)	Overload Trip Level	OLT level	30 - 150 %	120	Yes	6-19
FUN-68	Overload Trip Delay Time	OLT time	0 - 60 secs.	60.0	Yes	6-19
FUN-69	Input/Output Phase Loss Protection	Trip select	000 - 111 Bit Set	001	Yes	6-19
FUN-70	Stall Prevention Mode Selection	Stall Mode	No, Yes	No	No	6-20
FUN-71 (Note 16)	Stall Prevention Level	Stall level	30 - 200 %	100	No	6-20
FUN-72	Accel/Decel Change Frequency	Acc/Dec ch F	0 - FUN-30 Hz.	0	No	6-21
FUN-73	Reference Frequency for Accel and Decel	Acc/Dec Freq	Max, Delta	Max	No	6-21
FUN-74	Accel/Decel Time Scale	Time scale	0.01 secs. 0.1 secs. 1 sec.	0.1	Yes	6-22
FUN-75	Up/Down Save Mode	UpDnSaveMode	No, Yes	No	No	6-22
FUN-76 (Note 17)	Up?Down Save Frequency	UpDnSaveFreq	0.00 – FUN-30	0	View Only	6-22
FUN-80 (Note 18)	Over Heat Warning Level	OH Warn Levl	0 – 100%	90%	Yes	6-22
FUN-81 (Note 16)	Analog Stall Source	AnaStall Src	None I V1 Pulse	None	No	6-23
FUN-82	Current Limit Level	Max Ana Perc	30 – 200%	100	No	6-23

PARAM	Description	LCD Keypad Display	Setting Range	Factory Default	Adj. During Run	Page
	<p> The gray-highlighted parameters are hidden parameters and will appear when the related functions are set.</p> <p><b>Note 7:</b> FUN-04 and FUN-05 only displayed when FUN-03 is set to “S-Curve”.</p> <p><b>Note 8:</b> FUN-11 and FUN-12 only displayed when FUN-10 is set to “yes”.</p> <p><b>Note 9:</b> FUN-21 and FUN-22 only displayed when FUN-20 is set to “Dc-start”.</p> <p><b>Note 10:</b> FUN-24 through FUN-27 only displayed when FUN-23 is set to “Dc-brake”.</p> <p><b>Note 11:</b> FUN-34 and FUN-35 only displayed when FUN-33 is set to “yes”.</p> <p><b>Note 12:</b> FUN-41 through FUN-48 only displayed when FUN-40 is set to “User V/F”.</p> <p><b>Note 13:</b> FUN-52 only displayed when FUN-51 is set to “Manual”.</p> <p><b>Note 14:</b> FUN-58 and FUN-59 only displayed when FUN-57 is set to “yes”.</p> <p><b>Note 15:</b> FUN-67 and FUN-68 only displayed when FUN-66 is set to “yes”.</p> <p><b>Note 16:</b> FUN-71, 81 and 82 only displayed when FUN-70 is set to “yes”.</p> <p><b>Note 17:</b> FUN-76 only displayed when FUN-75 is set to “yes”.</p> <p><b>Note 18:</b> FUN-80 only displayed when any output relay is set to “OH Warn”.</p>					

**5.3 AFN (Advanced Function Group) Parameter List**  
**[AFN GROUP]**

PARAM	Description	LCD Keypad Display	Setting Range	Factory Default	Adj. During Run	Page
AFN-00	Jump Code – Program specific parameter #, hit enter to jump to that parameter.	Jump code	1 - 95	40	Yes	6-25
AFN-01	Last trip 1	Last trip-1	By pressing [PROG] and [▲] key, the frequency, current, and operational status at the time of fault can be seen.	None	View Only	6-25
AFN-02	Last trip 2	Last trip-2		None	View Only	6-25
AFN-03	Last trip 3	Last trip-3		None	View Only	6-25
AFN-04	Last trip 4	Last trip-4		None	View Only	6-25
AFN-05	Last trip 5	Last trip-5		None	View Only	6-25
AFN-06	Erase trips	Erase trips	No, Yes	No	Yes	6-25
AFN-07	Dwell Time	Dwell time	0 - 10 secs.	0.0	No	6-25
AFN-08 (Note 19)	Dwell Frequency	Dwell freq	FUN-32 - FUN-30 Hz.	5	No	6-25
AFN-10	Frequency Jump Selection	Jump freq	No, Yes	No	No	6-26
AFN-11 (Note 20)	Jump Frequency 1 Low	jump Lo1 Fre	0 - AFN-12 Hz.	10	Yes	6-26
AFN-12	Jump Frequency 1 High	jump Hi1 Fre	AFN-11- FUN-30 Hz.	15	Yes	
AFN-13	Jump Frequency 2 Low	jump Lo2 Fre	0 - AFN-14 Hz.	20	Yes	
AFN-14	Jump Frequency 2 High	jump Hi2 Fre	AFN-13- FUN-30 Hz.	25	Yes	
AFN-15	Jump Frequency 3 Low	jump Lo3 Fre	0 - AFN-16 Hz.	30	Yes	
AFN-16	Jump Frequency 3 High	jump Hi3 Fre	AFN-15- FUN-30 Hz.	35	Yes	
AFN-20	Power ON Start Selection	Power-on run	No, Yes	No	Yes	6-27
AFN-21	Restart after Fault Reset	RST restart	No, Yes	No	Yes	
AFN-22	Instantaneous Power Failure (IPF) restart	IPF Mode	No, Yes	No	No	6-28
AFN-23	Speed Search	Estimated SS	Fixed	Estimated SS	View Only	6-28
AFN-24	Auto Fault Reset	Retry Mode	No, Yes	No	Yes	6-28
AFN-25 (Note 21)	Number of Auto Retry	Retry number	0 - 10	0	Yes	6-28
AFN-26	Delay Time Before Auto Retry	Retry delay	0 - 60 secs.	1	Yes	6-28
AFN-27	Flying Percentage	Flying Perc	50 – 160%	70%	No	6-29



PARAM	Description	LCD Keypad Display	Setting Range	Factory Default	Adj. During Run	Page	
AFN-40	Rated Motor Selection	Motor select	7.5HP ~ 700HP	*	Depending on the inverter capacity	No	6-29
AFN-41	Number of Motor Poles	Pole number	2 - 12	4	No	6-29	
AFN-42	Rated Motor Slip	Slip Freq	0 - 10 Hz.	*	No	6-29	
AFN-44	No Load Motor Current(RMS)	Noload-Curr	0.5 - 999.9 A		Depending on AFN-40		No
AFN-45	Motor Efficiency	Efficiency	70 - 100 %		No		
AFN-46	Load Inertia	Inertia rate	1 - 40		10		No
AFN-47	Gain for Motor Speed Display	RPM factor	1 - 1000 %	100	Yes	6-30	
AFN-48	Carrier Frequency	Carrier freq	7.5 ~ 30 HP	0.7~15 kHz	5 kHz	Yes	6-31
			40 HP	0.7~10 kHz		Yes	
			50 ~ 100 HP	0.7~4 kHz	4 kHz	Yes	
			125 ~ 400 HP	0.7~3 kHz	3 kHz	Yes	
			500 ~ 700 HP	0.7~2 kHz	2 kHz	Yes	
AFN-49	PWM Type Selection	PWM select	Normal Low Leakage	Low-Leakage	No	6-31	
AFN-52 (Note 22)	Decel Rate (Safety Stop)	Dec Rate	1 – 100 secs.	100	Yes	6-31	
AFN-53	Safety Percentage	Safety_perc	2 – 500 %	21	Yes	6-31	
AFN-60	Control Mode Selection	Control mode	V/F	V/F	No	6-32	
			Slip Compensation				
			Sensorless				
AFN-61	Auto Tuning Selection	Auto tuning	No, Yes	No	No	6-33	
AFN-62	Stator Resistance of Motor	Rs	0 - (depending on AFN-40) ohm	*	No		
AFN-63	Leakage Inductance of Motor	Lsigma	0 - (depending on AFN-40) mH	Depending on AFN-40	No		
AFN-64 (Note 23)	Pre-excitation Time	PreEx time	0 - 60 secs.	1	No	6-34	

## Chapter 5 – Parameter List

PARAM	Description	LCD Keypad Display	Setting Range	Factory Default	Adj. During Run	Page
AFN-65	P Gain for Sensorless Control	SL P-gain	0 - 9999	3000	Yes	6-34
AFN-66	I Gain for Sensorless Control	SL I-gain	0 - 9999	1000	Yes	6-34
AFN-67	Manual/Auto Torque Boost Selection	Torque boost	Manual	Manual	No	6-35
			Auto			
AFN-68	Torque Boost in Forward Direction	Fwd boost	0 - 15 %	2	No	6-35
AFN-69	Torque Boost in Reverse Direction	Rev boost	0 - 15 %	2	No	
AFN-80	Power On display	PowerOn disp	0 - 12	0	Yes	6-36
AFN-81	User Display Selection	User disp	Voltage	Voltage	Yes	6-36
			Watt			
AFN-82	Software Version	iP5A Benshaw	Ver 1.0	Ver X.XX	View Only	6-36
AFN-83	Last Trip Time	LastTripTime	X:XX:XX:XX:XX:X		View Only	6-36
AFN-84	Power On Time	On-time	X:XX:XX:XX:XX:X		View Only	
AFN-85	Run-time	Run-time	X:XX:XX:XX:XX:X		View Only	
AFN-87	Power Display Adjustment	Power Set	0.1 - 400 %	100	Yes	
AFN-90	Parameter Display	Para. disp	Default	Default	No	6-37
			All Para			
			Diff Para			
AFN-91	Read Parameter	Para. Read	No	No	No	6-37
			Yes			
AFN-92	Write Parameter	Para. Write	No	No	No	6-37
			Yes			
AFN-93	Initialize Parameters	Para. init	No	No	No	6-38
			All Groups			
			DRV			
			FUN			
			AFN			
			I/O			
			EXT			
			COM			
APP						
AFN-94	Parameter Write Protection	Para. Lock	0 - 9999	0	Yes	6-38
AFN-95	Parameter Save	Para. save	No	No	No	6-38
			Yes			
AFN-96	Password Register	PW Register	0001-9999	0	Yes	6-38

PARAM	Description	LCD Keypad Display	Setting Range	Factory Default	Adj. During Run	Page
<p><input type="checkbox"/> The gray-highlighted parameters are hidden parameters and will appear when the related functions are set.</p> <p><b>Note 19:</b> AFN-08 is only displayed when AFN-07 is set to <math>\geq 1</math> sec.</p> <p><b>Note 20:</b> AFN-11 through AFN-16 are only displayed when AFN-10 is set to 'Yes'.</p> <p><b>Note 21:</b> AFN-25 and AFN-26 are only displayed when AFN-24 is set to "yes".</p> <p><b>Note 22:</b> AFN-52 and AFN-53 only displayed when FUN-28 (Safety Stop) is set to "yes".</p> <p><b>Note 23:</b> AFN-64 through AFN-66 only displayed when AFN-60 is set to "Sensorless".</p>						

5.4 I/O (Input/Output Group) Parameter List

[I/O GROUP]

PARAM	Description	LCD Keypad Display	Setting Range	Factory Default	Adj. During Run	Page
I/O-00	Jump Code – Program a specific parameter #, hit enter to jump to that parameter	Jump code	1 - 98	1	Yes	6-39
I/O-01 (Note 24)	Filtering Time Constant for V1 Signal Input	V1 filter	0 - 9999 msec	10	Yes	6-39
I/O-02	V1 Input Minimum Voltage	V1 volt x1	0 – I/O-04 V	0	Yes	
I/O-03	Frequency Corresponding to V1 Input Minimum Voltage	V1 freq y1	0 - FUN-30 Hz	0	Yes	
I/O-04	V1 Input Maximum Voltage	V1 volt x2	0 – 12 V	10	Yes	
I/O-05	Frequency Corresponding to V1 Input Maximum Voltage	V1 freq y2	0 - FUN-30 Hz	60	Yes	
I/O-06	Filtering Time Constant for I Signal Input	I filter	0 - 9999 msec	10	Yes	6-40
I/O-07	I Input Minimum Current	I curr x1	0 - I/O-09 mA	4	Yes	
I/O-08	Frequency Corresponding to I Input Minimum Current	I freq y1	0 - FUN-30 Hz	0	Yes	
I/O-09	I Input Maximum Current	I curr x2	0 - 20 mA	20	Yes	
I/O-10	Frequency Corresponding to I Input Maximum Current	I freq y2	0 - FUN-30 Hz	60	Yes	
I/O-11	Pulse input method	P pulse set	A	A	Yes	6-41
I/O-12	Pulse input filter	P filter	0 - 9999 msec	10	Yes	
I/O-13	Pulse input Minimum frequency	P pulse x1	0 - 10 kHz	0	Yes	
I/O-14	Frequency corresponding to I/O-13 Pulse input Minimum frequency	P freq y1	0 - FUN-30 Hz	0	Yes	
I/O-15	Pulse Input Maximum Frequency	P pulse x2	0 - 100 kHz	10	Yes	
I/O-16	Frequency corresponding to I/O-15 Pulse input Maximum frequency	P freq y2	0 - FUN-30 Hz	60	Yes	
I/O-17	Criteria for Analog Input Signal Loss	Wire broken	None half of x1 below x1	None	Yes	6-42

PARAM	Description	LCD Keypad Display	Setting Range	Factory Default	Adj. During Run	Page
I/O-18	Operating selection at Loss of Freq. Reference	Lost command	None Free Run Stop Protection	None	Yes	6-42
I/O-19	Waiting Time after Loss of Freq. Reference	Time out	0.1 - 120 sec	1.0	Yes	
I/O-20	Multi-Function Input Terminal 'M1' Define	M1 define	Speed-L Speed-M Speed-H XCEL-L XCEL-M XCEL-H Dc-brake 2nd Func Exchange Reserved UpDown 3-Wire Ext Trip Pre-Heat iTerm Clear Open-loop LOC/REM Analog hold XCEL stop P Gain2 Reserved Interlock1 Interlock2 Interlock3 Interlock4 Speed_X RST BX JOG FX RX ANA_CHG Ext PID Run Up/Dn Clr	Speed-L	Yes	6-43

## Chapter 5 – Parameter List

PARAM	Description	LCD Keypad Display	Setting Range	Factory Default	Adj. During Run	Page
I/O-21	Multi-function Input Terminal 'M2' Define	M2 define	Same as I/O-20	Speed-M	Yes	6-43
I/O-22	Multi-function Input Terminal 'M3' Define	M3 define	Same as I/O-20	Speed-H	Yes	
I/O-23	Multi-function Input Terminal 'M4' Define	M4 define	Same as I/O-20	RST	Yes	
I/O-24	Multi-function Input Terminal 'M5' Define	M5 define	Same as I/O-20	BX	Yes	
I/O-25	Multi-function Input Terminal 'M6' Define	M6 define	Same as I/O-20	JOG	Yes	
I/O-26	Multi-function Input Terminal 'M7' Define	M7 define	Same as I/O-20	FX	Yes	6-43
I/O-27	Multi-function Input Terminal 'M8' Define	M8 define	Same as I/O-20	RX	Yes	
I/O-28	Terminal Input Status	In status	0000000000 1111111111	0000000000	View Only	6-44
I/O-29	Filtering Time Constant for Multi-Function Input Terminals	Ti Filt Num	2 - 1000 msec	15	Yes	
I/O-30	Jog Frequency Setting	Jog freq	0 to FUN-30 Hz.	10	Yes	6-44
I/O-31	Step Frequency 4	Step freq-4		40	Yes	
I/O-32	Step Frequency 5	Step freq-5		50	Yes	
I/O-33	Step Frequency 6	Step freq-6		40	Yes	
I/O-34	Step Frequency 7	Step freq-7		30	Yes	
I/O-35 (Note 25)	Step Frequency 8	Step freq-8		20	Yes	
I/O-36	Step Frequency 9	Step freq-9		10	Yes	
I/O-37	Step Frequency 10	Step freq-10		20	Yes	
I/O-38	Step Frequency 11	Step freq-11		30	Yes	
I/O-39	Step Frequency 12	Step freq-12		40	Yes	
I/O-40	Step Frequency 13	Step freq-13		50	Yes	
I/O-41	Step Frequency 14	Step freq-14		40	Yes	
I/O-42	Step Frequency 15	Step freq-15		30	Yes	
I/O-50	Acceleration Time 1	Acc time-1		0 - 6000 sec	20	
	(for Step speed)		Yes			
I/O-51	Deceleration Time 1	Dec time-1	0 - 6000 sec	20	Yes	
	(for Step speed)				Yes	
I/O-52 (Note 26)	Acceleration Time 2 (for Step speed)	Acc time-2	0 - 6000 sec	30	Yes	
I/O-53	Deceleration Time 2	Dec time-2	0 - 6000 sec	30	Yes	
I/O-54	Acceleration Time 3	Acc time-3	0 - 6000 sec	40	Yes	
I/O-55	Deceleration Time 3	Dec time-3	0 - 6000 sec	40	Yes	
I/O-56	Acceleration Time 4	Acc time-4	0 - 6000 sec	50	Yes	

PARAM	Description	LCD Keypad Display	Setting Range	Factory Default	Adj. During Run	Page
I/O-57	Deceleration Time 4	Dec time-4	0 - 6000 sec	50	Yes	
I/O-58	Acceleration Time 5	Acc time-5	0 - 6000 sec	40	Yes	6-46
I/O-59	Deceleration Time 5	Dec time-5	0 - 6000 sec	40	Yes	
I/O-60	Acceleration Time 6	Acc time-6	0 - 6000 sec	30	Yes	
I/O-61	Deceleration Time 6	Dec time-6	0 - 6000 sec	30	Yes	
I/O-62	Acceleration Time 7	Acc time-7	0 - 6000 sec	20	Yes	
I/O-63	Deceleration Time 7	Dec time-7	0 - 6000 sec	20	Yes	
I/O-70	S0 output selection	S0 mode	Frequency Current Voltage DC link Vtg Ext PID Out Watts	Frequency	Yes	
I/O-71	S0 output adjustment	S0 adjust	10 - 200 %	100	Yes	6-50
I/O-72	S1 output selection	S1 mode	Same as I/O-70	Voltage	Yes	
I/O-73	S1 output adjustment	S1 adjust	10 - 200 %	100	Yes	
I/O-74	Frequency Detection Level	FDT freq	0 - FUN-30 Hz	30	Yes	6-51
I/O-75	Frequency Detection Bandwidth	FDT band	0 - FUN-30 Hz	10	Yes	6-51
I/O-76	Multi-Function Auxiliary Contact Output A1-C1 (Aux terminal)	Aux mode1	NONE FDT-1 FDT-2 FDT-3 FDT-4 FDT-5 OL IOL Stall OV LV OH Lost Command Run Stop Steady INV line	NONE	Yes	6-51

## Chapter 5 – Parameter List

I/O-76 (con't)	Multi-Function Auxiliary Contact Output A1-C1 (con't)		COMM line			6-51
			SpeedSearch			
			Ready			
			MMC			
			OH Warn			
			FAN Signal			
			RMT Status			
I/O-77	Multi-Function Auxiliary Contact Output A2-C2	Aux mode2	Same as I/O-76	NONE	Yes	6-51
I/O-78	Multi-Function Auxiliary Contact Output A3-C3	Aux mode3	Same as I/O-76	NONE	Yes	
I/O-79	Multi-Function Auxiliary Contact Output A4-C4	Aux mode4	Same as I/O-76	NONE	Yes	
I/O-80	Fault Output Relay Setting (30A, 30B, 30C)	Relay mode	000 - 111 bit	010	Yes	6-55
I/O-81	Terminal Output Status	Out status	00000000 11111111	0	View Only	6-55
I/O-82	Fault Output Relay On Delay Time	Relay On	0 - 9999 secs.	0	No	6-55
I/O-83	Fault Output Relay Off Delay Time	Relay Off	0 - 9999 secs.	0	No	
I/O-84	Fan Con Sel (50 ~ 700HP)	Fan Con. Sel	PowerOn_Fan	PowerOn_ Fan	No	6-56
			Run Fan			
			Temper-Fan			
I/O-85	Fan Temp (50 ~ 700HP)	Fan Temp	0 - 70 °C	70	Yes	6-56
I/O-86 (Note 27)	Analog Input User Unit Selection	Unit Sel	Speed Percent Bar mBar kPa Pa PSI	PSI	No	6-56
			I/O-87 (Note 27)			



PARAM	Description	LCD Keypad	Setting Range	Factory Default	Adj. During Run	Page
		Display				
I/O-90	Inverter Number	Inv No.	1 - 250	1	Yes	6-57
I/O-91	Baud Rate Selection	Baud rate	1200 bps	9600	Yes	
			2400 bps			
			4800 bps			
			9600 bps			
			19200 bps			
			38400 bps			
I/O-92	Operating method at loss of frequency reference	COM Lost Cmd	None	None	Yes	6-57
			FreeRun			
			Stop			
I/O-93	Loss of Communication Delay Time	COM Time Out	0.1 - 120 sec	1.0	Yes	6-57
I/O-94	Communication Response Delay time	Delay Time	2 - 1000 msec	5	Yes	6-57
I/O-95	A or B contact	In No/Nc Set	0000000000 1111111111	0	No	6-58
I/O-96	Input time	In CheckTime	1 - 1000 msec	1	No	6-58
I/O-97	Overheat trip selection	OH Trip Sel	000 - 111 bit	010	No	6-58
I/O-98	Motor overheat trip temperature	MotTripTemp.	0 - 255 °C	110	No	

 The gray-highlighted parameters are hidden parameters and will appear when the related functions are set.

**Note 24:** When DRV-04 and/or DRV-92 are set to either V1, V1S, I, V1+I, or Pulse only selected parameters are displayed in I/O-01~I/O-19.

**Note 25:** I/O-35 ~ I/O-42 displayed only when one of I/O-20 ~ I/O-27 is set to Speed\_X.

**Note 26:** I/O-52 ~ I/O-63 displayed only when one of I/O-20 ~ I/O-27 is set to either XCEL\_L, XCEL\_M, XCEL\_H.

**Note 27:** When Process PI Control is selected with APP-02, select units with I/O-86 and the maximum value of the units with I/O-87. See also APP-06, APP-31, APP-32 and APP-33.

5.5 APP (Application Group) Parameter List

[APP GROUP]

PARAM	Description	LCD Keypad Display	Setting Range	Factory Default	Adj. During Run	Page
APP-00	Jump Code – Program a specific parameter #, hit enter to jump to that parameter	Jump code 1	1 ~ 97	Yes	Yes	6-61
APP-01 (Note 28)	Application Mode Selection	App mode	None MMC	None	No	6-61
APP-02	PID Operation Selection	Proc PI mode	No, Yes	No	No	6-61
APP-03 (Note 29)	PID F Gain Selection	PID F-gain	0 - 999.9 %	0.00	Yes	6-66
APP-04 (Note 30)	PID Auxiliary Reference Mode Selection	Aux Ref Mode	No Yes	No	No	6-66
APP-05 (Note 31)	PID Auxiliary Reference Signal Selection	Aux Ref Sel	Keypad-1 Keypad-2 V1 V1S I V1+I Pulse Int. 485 Ext. PID	V1	No	6-66
APP-06	PID Feedback Signal Selection	PID F/B	I V1 Pulse	0 (I)	No	6-66
APP-07	P Gain for PID Control	PID P-gain	0 - 999.9 %	1.00	Yes	6-66
APP-08	I Gain for PID Control	PID I-time	0 - 32.0 sec	10.0	Yes	6-66
APP-09	D Gain for PID Control	PID D-time	0 -100 msec	0.0 msec	Yes	6-66
APP-10	High Limit Frequency for PID Control	PID limit-H	0.00 - 300.00 Hz	60 .00	Yes	6-67
APP-11	Low Limit Frequency for PID Control	PID limit-L	Start Freq - 300.00 Hz	0.5	Yes	6-67
APP-12	PID Output Scale	PID Out Scale	0.0 - 999.9 %	100.00	No	6-67
APP-13	PID P2 Gain	PID P2-gain	0.0 - 999.9 %	100.00	No	6-67
APP-14	P Gain Scale	P-gain Scale	0.0 - 100.0 %	100.00	No	6-67
APP-15	PID Output Inverse	Out inverse	No Yes	No	No	
APP-17	PID U curve feedback select	PID U Fbk	No Yes	No	No	
APP-20 (Note 32)	2nd Acceleration Time	2nd Acc time	0 - 6000 sec	5	Yes	6-68

PARAM	Description	LCD Keypad Display	Setting Range	Factory Default	Adj. During Run	Page
APP-21	2nd Deceleration Time	2nd Dec time	0 - 6000 sec	10	Yes	
APP-22	2nd Base Frequency	2nd BaseFreq	30 - FUN-30 Hz	60	No	6-68
APP-23	2nd V/F Pattern	2nd V/F	Linear Square User V/F	Linear	No	6-68
APP-24	2nd Forward Torque Boost	2nd F-boost	0 - 15 %	2	No	
APP-25	2nd Reverse Torque Boost	2nd R-boost	0 - 15 %	2	No	
APP-26	2nd Stall Prevention Level	2nd Stall	30 - 150 %	100	No	
APP-27	2nd Electronic Thermal Level for 1 minute	2nd ETH 1min	AFN-28 - 200 %	130	Yes	6-68
APP-28	2nd Electronic Thermal Level for continuous	2nd ETH cont	50 - AFN-27 (Max. 150%)	120	Yes	
APP-29	2nd Rated Motor Current	2nd R-Curr	1 - 200 A	3.6	No	
APP-31 (Note 34)	Meter I Max Value	Meter I max	0 – 20 mA	20	Yes	6-68
APP-32 (Note 34)	Meter V1 Max Value	Meter V max	0 – 12 V	10V	Yes	6-68
APP-33 (Note 34)	Meter P Max Value	Meter P max	0 – 100 kHz.	100kHz	Yes	6-68
APP-40 (Note 28)	Number of Auxiliary Motor Run Display	Aux Mot Run	View Only	View Only	View Only	6-69
APP-41	Aux. Motor Start Selection	Starting Aux	1 - 4	1	Yes	
APP-42	Operation Time Display on Auto Change	Auto Op Time	View Only	View Only	View Only	
APP-43	The Number of Aux Motor	Nbr Aux`s	0 - 4	4	Yes	
APP-44	Start Frequency of Aux. Motor 1	Start freq 1	0 - FUN-30 Hz	49.99	Yes	6-70
APP-45	Start Frequency of Aux. Motor 2	Start freq 2		49.99	Yes	
APP-46	Start Frequency of Aux. Motor 3	Start freq 3		49.99	Yes	
APP-47	Start Frequency of Aux. Motor 4	Start freq 4		49.99	Yes	
APP-51	Stop Frequency of Aux. Motor 1	Stop freq 1	0 - FUN-30 Hz	20.00	Yes	6-70
APP-52	Stop Frequency of Aux. Motor 2	Stop freq 2		20.00	Yes	
APP-53	Stop Frequency of Aux. Motor 3	Stop freq 3		20.00	Yes	
APP-54	Stop Frequency of Aux. Motor 4	Stop freq 4		20.00	Yes	
APP-58	Delay Time before Operating Aux Motor	Aux start DT	0.0 - 999.9 sec	5.0	Yes	6-71

## Chapter 5 – Parameter List

PARAM	Description	LCD Keypad Display	Setting Range	Factory Default	Adj. During Run	Page
APP-59	Delay Time before Stopping Aux Motor	Aux stop DT	0.0 - 999.9 sec	5.0	Yes	6-71
APP-60	Accel time when the number of pump decreases	Pid AccTime	0 - 600.0 sec	2.0	Yes	6-71
APP-61	Decel time when the number of pump increases	Pid DecTime	0 - 600.0 sec	2.0	Yes	6-71
APP-62	PID Bypass Selection	Regul Bypass	No Yes	No	No	6-71
APP-63 (Note 29)	Sleep Delay Time	Sleep Delay	0.0 - 9999 sec	60.0	Yes	6-72
APP-64	Sleep Frequency	Sleep Freq	0 - FUN-30 Hz	0.00	Yes	6-72
APP-65	Wake-Up Level	WakeUp level	0.0 - 100.0 %	35 .00	Yes	6-72
APP-66 (Note 28)	Auto Change Mode Selection	AutoCh_Mode	0 1 (Aux) 2 (Main)	0	Yes	6-73
APP-67	Auto Change Time	AutoEx-intv	00:00 - 99:00	72:00:00	Yes	6-73
APP-68	Auto Change Frequency	AutoEx-Freq	FUN-32 - FUN-30 Hz	20.0	Yes	6-73
APP-69	Inter-Lock Selection	Inter-lock	No Yes	No	Yes	6-75
APP-71 (Note 28)	Pressure difference for Aux motor Start	Aux Stt Diff	0 - 100 %	2	Yes	6-76
APP-72	Pressure difference for Aux motor Stopt	Aux Stp Diff	0 – 100%	2	Yes	6-76
APP-74 (Note 29)	PrePID Reference Frequency	PrePID freq	0 - FUN-30 Hz	0	Yes	6-76
APP-75	PrePID Exit Level	PrePID Exit	0 - 100.0%	0	Yes	
APP-76	PrePID Stop delay	PrePID dly	0 - 9999	600	Yes	
APP-77	Pipe Broken	Pipe Broken	No, Yes	No	Yes	
APP-78 (Note 28)	Stopping Order of Aux Motors First input – Last Output	F-In L-Out	Yes, No	Yes	No	6-77
APP-79	Stopping method of Aux motors	All-Stop	Yes, No	Yes	No	6-77
APP-80	Ext PID Operation Selection	Ext PI mode	No Yes	No	No	6-77
APP-81 (Note 33)	Ext PID Reference Signal Selection	Ext Ref Sel	I V1 Pulse Keypad	Keypad	No	6-77
APP-82	Ext PID Reference Level	Ext Ref Perc	0 - 100.00 %	50.00	No	6-77

PARAM	Description	LCD Keypad Display	Setting Range	Factory Default	Adj. During Run	Page
APP-83	Ext PID Feedback Signal Selection	Ext Fbk Sel	I V1 Pulse	I	No	6-77
APP-85	P Gain for ExtPID	ExtPID Pgain	0 - 999.9 %	1.00	No	6-77
APP-86	I Time for ExtPID	ExtPID Itime	0 - 32.0 sec	10.0	No	6-77
APP-87	D Time for ExtPID	ExtPID Dtime	0 - 2000 msec	0	No	6-77
APP-88	High Limit Frequency for ExtPID Control	ExtPID lmt-H	0 - 100.00	100.00	No	6-77
APP-89	Low Limit Frequency for ExtPID Control	ExtPID lmt-L	0 - 30.00 %	0	No	6-77
APP-90	ExtPID Output Scale	ExtPID Scale	0 - 999.9 %	100.00	No	6-77
APP-91	ExtPID P2 Gain	Ext P2-gain	0 - 999.9 %	100.00	No	6-77
APP-92	ExtPID P Gain Scale	Ext P Scale	0 - 100.0	100.00	No	6-77
APP-93	ExtPID F Gain	ExtPID F-gain	0 - 999.9 %	0.00	Yes	6-77
APP-95	ExtPID Output Inverse	ExtOut inverse	No Yes	No	No	6-77
APP-97	ExtPID Loop Time	Ext Loop Time	50 - 200 msec	100	No	6-77

The gray-highlighted parameters are hidden parameters and will only appear when the related functions are set.

**Note 28:** Only APP-40~APP-62, APP-66~APP-69, APP-71, 72, 78 and 79 are displayed when APP-01 is set to “MMC”.

**Note 29:** Only APP-03~APP-17, APP-31~APP-33, APP-63~APP-65 and APP-74~APP-77 are displayed when APP-02 is set to “Yes”.

**Note 30:** If APP-04 is set to “NO”, DRV-04 setting will be reference (set point) of process PID. And APP -05 setting will be ignored.

**Note 31:** If APP-04 is set to “Yes”, APP-05 will appear. And APP -05 setting value will be reference (set point) of process PID, DRV-04 setting will be ignored.

**Note 32:** Only APP-20 ~ APP-29 displayed only when one of I/O-20 ~ I/O-27 is set to either “2nd Func”.

**Note 33:** Only APP-81 ~ APP-97 displayed when APP-80 is set to “Yes”.

**Note 34:** Only one of APP-31, 32 or 33 are displayed dependant on APP-06 selection (I, V1, Pulse).

**5.6 EXT (4-20mA Output Option Card) Parameter List**  
**[EXT GROUP]**

PARAM	Description	LCD Keypad Display	Setting Range	Factory Default	Adj. During Run	Page
EXT-00	Jump Code – Jump directly to any parameter by programming the desired parameter #	Jump code	1 - 45	1	Yes	Refer to the corresponding option manual
EXT-01	Type of Option Board	Sub B/D	Sub-E	View Only	View Only	
EXT-40	Current Output Terminal 1(CO1) Selection	AM1 mode	Frequency Current Voltage DC link Vtg Ext PID Out Watt	Frequency	Yes	
EXT-41	Adjust Gain of Current Output Terminal 1(CO1)	AM1 adjust	10 – 200 %	100	Yes	
EXT-42	Adjust Offset of Current Output Terminal 1(CO1)	AM1 Offset	0 – 100 %	0	Yes	
EXT-43	Current Output Terminal 2(CO2)	AM2 mode	Frequency Current Voltage DC link Vtg Ext PID Out Watt	DC link Vtg	Yes	
EXT-44	Adjust Gain of Current Output Terminal 2(CO2)	AM2 adjust	10 – 200 %	100	Yes	
EXT-45	Adjust Offset of Current Output Terminal 2(CO2)	AM2 Offset	0 – 100 %	0	Yes	

**Note 1:** The EXT group is only displayed when the 4-20mA option board is installed. Part # RSI-SG-4-20-mA.

**Note 2:** Refer to manual 890027-11-00 for further information.

## ■ Notes





## Chapter 6. Parameter Descriptions

### 6.1 Drive Group [DRV]

#### DRV-00: Command Frequency / Output Current

DRV▶ T/K 0.0A  
00 STP 0.00 Hz

Factory Default: 0.00 Hz

#### 1) Digital frequency setting

This parameter is used to set the command frequency when DRV-04 [Frequency Mode] is set to Keypad-1 or Keypad-2. It can be set to a value equal to or less than FUN-30 [Maximum Frequency].

#### 2) Monitoring function setting

The command frequency is displayed during stop. Output current and frequency are displayed during run.

When DRV-04 [Frequency Mode] is set to V1, V1S, I, V1+I or Pulse the drive will display the reference frequency during stop.

If PID control is active the user can change the units to be displayed in I/O-86.

When DRV-17 [Speed Unit Selection] is set to Rpm, the display will show RPM rather than Hz.

#### DRV-01, 02: Accel/Decel Time

DRV▶ Acc. time  
01 20.0 sec

Factory Default: 20.0 sec

DRV▶ Dec. time  
02 30.0 sec

Factory Default: 30.0 sec

The acceleration time is the amount of time that it takes (from zero Hz.) for the drive to reach the maximum frequency set in FUN-30 when the drive receives a start command. The deceleration time is amount of time the drive takes to stop from the maximum

frequency in FUN-30 to 0Hz when a stop command is given.

When FUN-73 is set to “Delta Frequency”, the acceleration and deceleration time is the time taken to reach a target frequency (instead of the maximum frequency) from a specific frequency.

**Note: Set the Accel time more than 0.5 sec for smooth acceleration. Setting it too short may deteriorate the starting performance.**

#### DRV-03: Drive Mode (Run/Stop Method)

DRV▶ Drive mode  
03 Fx/Rx-1

Factory Default: Fx/Rx-1

This parameter selects the source of run/stop command.

LCD Setting Range	Description
Keypad	Run/Stop control by Keypad.
Fx/Rx-1	Run/Stop control by Control Terminals FX, RX. (Method 1) FX: Two wire contact for forward Run/Stop RX: Two wire contact for reverse Run/Stop
Fx/Rx-2	Run/Stop control by Control Terminals FX, RX. (Method 2) FX: Two wire for Run/Stop command RX: Two wire for Forward/Reverse selection (Open-Fwd, Closed-Rev)
Int. 485	Run/Stop control by Modbus.

**DRV-04: Frequency Mode**

DRV▶ Freq mode  
04 Keypad-1

Factory Default: Keypad-1

This parameter selects the method of speed control for the drive.

LCD Setting Range	Description
Keypad-1	Frequency is set at DRV-00. The frequency is changed by pressing <b>PROG</b> key and entered by pressing <b>ENTER</b> key. The drive does not output the changed frequency until the <b>ENTER</b> key is pressed.
Keypad-2 (EMOP)	Frequency is set at DRV-00. Press <b>PROG</b> key and then by pressing the <b>▲</b> , <b>▼</b> key, the drive immediately outputs the changed frequency. Pressing the <b>ENTER</b> key saves the changed frequency.
V1	The drive uses <b>V1</b> (0-12V) signal for speed control. Refer to I/O-01 to I/O-05 for scaling the signal.
V1S	The drive uses <b>V1</b> (-12V to 12V) as a bipolar input. Refer to I/O-01 to I/O-05 for scaling the signal.
I	The drive uses <b>I</b> (4~20mA) signal for speed control. Refer to I/O-06 to I/O-10 for scaling the signal.
V1+I	The drive uses both the <b>V1</b> and <b>I</b> (0~12V, 4~20mA) control terminals. The ' <b>V1</b> ' signal overrides the ' <b>I</b> ' signal. See I/O-01~ I/O-10.
PULSE	The drive uses the " <b>A0</b> , <b>B0</b> " terminals. Range: 0~100kHz. See I/O-11~16.
Int. 485	The drive uses Modbus communication. See I/O-90~93.

LCD Setting Range	Description
Ext. PID	Set APP-80 [Ext PI Mode] to "Yes." Apply Ext. PID feedback value "4~20mA" to control terminal "I". Set one of the I/O-20~27 to [Ext PID Run]. Drive starts Ext.PID operation when the defined terminal is ON and Ext.PID output value becomes the drives command frequency. See APP-80~97 for details.

**DRV-05: Motor Rated Current**  
**DRV-06: Electronic Thermal (Motor i<sup>2</sup>t) Selection**  
**DRV-07: Electronic Thermal Level for 1 Minute**  
**DRV-08: Electronic Thermal Level for Continuous**  
**DRV-09: Electronic Thermal Characteristic (Motor type) selection**

These parameters are to provide motor OL protection without using an external OL relay. The drive calculates the temperature rise in the motor based on several parameters and determines whether or not the motor is overheated. When an ETH trip occurs the drive will fault and display E-THERMAL. The drive cannot be reset immediately after an Eth trip. A cool down period of approximately one minute is required prior to resetting the drive.

DRV▶ Rated-Curr  
05 X.X A

Factory Default: Model Dependent  
(This value is preset according to the motor capacity set in AFN-40)

This parameter sets the motor rated full load current. This value is used by the ETH function as well other functions. This value also is referenced by many other parameters. (Refer to the motor nameplate for actual value)

**CAUTION** ⚠  
**The motor rated current must be set to the correct value for many of the drive's protective and control functions to operate correctly.**

DRV► ETH select  
06 --- Yes ---

Factory Default: Yes

This parameter activates the ETH function when set to 'Yes'. ETH level is set as the percentage of DRV-05 [Motor rated current].

DRV► ETH 1min  
07 130 %

Factory Default: 130 %

This is the one-minute current level that is used to determine the motor I<sup>2</sup>t overload curve. For example, if DRV-07 is set to 130%, the drive would trip in one minute if 130% of rated motor current in DRV-05 flows for one minute.

ETH Calculation:

$$TimeToTrip \approx 60sec. * \frac{\left(\frac{[DRV07]}{100\%}\right)^2 - 1}{\left(\frac{MotorCurrent}{[DRV05] * SpeedFactor}\right)^2 - 1}$$

**Note:** When  $\frac{MotorCurrent}{[DRV05] * [DRV08] * SpeedFactor} < 1$

The ETH will not charge and the drive will run continuously at that current and speed level.

**Note:** The set value is the percentage of DRV-05 [Rated Motor Current].

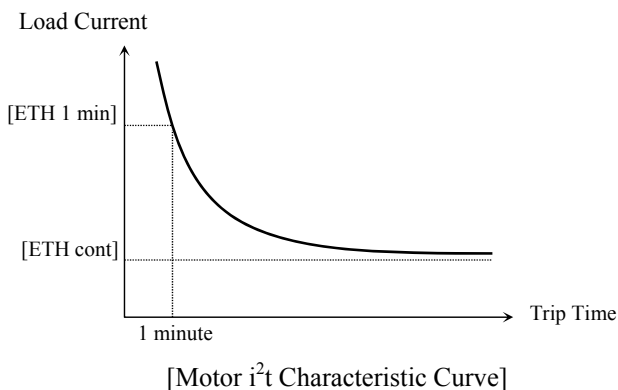

DRV► ETH cont  
08 100 %

Factory Default: 100 %

This is the current at which the motor can run continuously. This is often considered the service factor of the motor. Generally, this value is set to '100%', which means that the drive will begin accumulating motor OL once the current is above the motor rated current set in DRV-05. If this parameter is set to 115%, the drive will begin accumulating motor OL at 115% of the current in DRV-05

**Note:** This value must be set less than DRV-07 [ETH 1min].

**Note:** The set value is the percentage of DRV-05 [Rated Motor Current].

DRV► Motor type  
09 Self-cool

Factory Default: Self-cool

Since a motor often runs hotter at slower speeds, the SG drive provides derating of the ETH function for different types of motors. For proper motor protection utilizing the ETH parameters, the following type of motor must be selected:

[Self-cool] is a standard motor that has a cooling fan connected directly to the shaft of the motor. The fan will provide less cooling at lower speeds, causing the motor to run hotter. The drive will derate the motor OL calculations to protect the motor at lower speeds. It accomplishes this function by adjusting the speed factor, which is shown in the ETH calculations.

The speed factor for operation at and above 60Hz is 1.00.

The speed factor for operation between 20Hz and 60Hz is:

$$Speed\_Factor = (0.125 \% / Hz * drive\ frequency\ (Hz) + 92.5\%) / 100\%$$

## Chapter 6 - Parameter Description [DRV]

The speed factor for operation below 20Hz is:

$$\text{Speed\_Factor} = (1.5 \text{ \%}/\text{Hz} * \text{drive frequency (Hz)} + 65\%) / 100\%$$

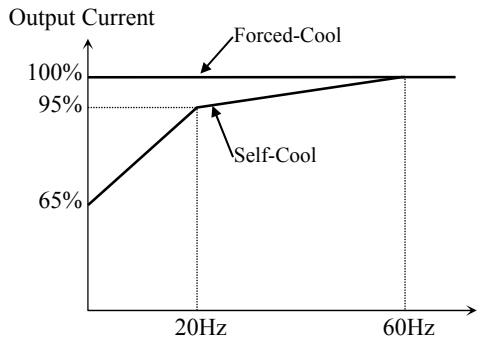

[Load Current Derating Curve]

**[Forced-cool]** is for a motor that uses a separate motor to power a cooling fan or an inverter duty motor that does not need to be derated at lower speeds. As the motor speed changes, the cooling affect does not change. The value set in DRV-08 [Electronic thermal level for continuous] is applied regardless of operating frequency. The Speed Factor for a forced cooled motor is always 1.0.

### DRV-10: Output Current

DRV▶ Current  
10 0.0 A

Factory Default: 0.0 A

This parameter displays the average three-phase output current.

### DRV-11 DC Link Voltage

DRV▶ DC link vtg  
11 ----- V

Factory Default: ----- V

This parameter displays the DC link (DC bus) voltage.

### DRV-12: User Display Selection

DRV▶ User disp  
12 0.0 V

Factory Default: 0.0 V

This parameter displays the value of the parameter selected in AFN-81 [User Display].

### DRV-13: Present Trip Display

DRV▶ Fault  
13 None

Factory Default: None

This parameter displays the present fault (trip) status of the drive. Use the **PROG**, **▲** and **▼** keys before pressing the **RESET** key to check the fault log content. Output frequency, output current, and the mode of operation when the fault occurred are displayed. Press the **ENTER** key to exit. The fault content will be stored in AFN-01 to AFN-05 after the **RESET** key is pressed.

For more detail, refer to Chapter 7. Troubleshooting and Maintenance.

### [Fault Contents]

Fault (Trip)	LCD Keypad display
Over-Current 1	Over Current 1
Over-Voltage	Over Voltage
External Trip Input	Ext. Trip
Inverter Disable (Not Latched)	BX
Low-Voltage	Low Voltage
Ground Fault	Ground Fault
Over-Heat on Heat sink	Over Heat
Electronic Thermal Trip	E-Thermal
Over-Load Trip	Over Load
Inverter H/W Fault - EEP Error - ADC Offset - WDOG Error - In-Phase Open	HW-Diag
Over-Current 2	Over Current 2
Output Phase Loss	Phase Open
Inverter Over-Load	Inv. OLT

**Note:** Certain Hardware faults such as: WDOG error, EEP error, Input Phase Open, Fan Lock, Blown Fuse, NTC Open and ADC Offset cannot be reset until the fault condition is corrected. The drive will not reset when a H/W fault occurs. Repair the fault before turning on the power.

**Note:** Only the highest-priority fault will be displayed when multiple faults occur. The other faults can be viewed in AFN-01~05 [Fault history]. Up to 5 faults are saved in AFN-01~05 [Fault history]. AFN-01, “Last trip-1” is the most recent fault. AFN-05, “Last trip 5” is the oldest fault. After pressing [PROG] key, press [↑(Up)], [↓(Down)] key to check the operational information at the time of the fault (Output freq., current, Accel/Decel/Constant Run) and fault type. Press the [ENTER] key to exit the fault log. AFN-06 [Erase fault history] clears the fault history. AFN-83 [Last Trip Time] is automatically set when a fault occurs.

Parameter	Display	Description
AFN-01	Last trip-1	Fault history 1
AFN-02	Last trip-2	Fault history 2
AFN-03	Last trip-3	Fault history 3
AFN-04	Last trip-4	Fault history 4
AFN-05	Last trip-5	Fault history 5

**DRV-14: Motor Speed**

DRV▶ Speed  
14 0rpm

Factory Default: 0rpm

This parameter displays the motor speed in RPM while the motor is running. It can also be displayed on the main screen, see DRV-17.

Use the following equation to scale the mechanical speed using AFN-47 [Gain for Motor Speed display] if you want to change the motor speed display to rotation speed (r/min) or mechanical speed (m/min).

$$\text{Motor speed} = 120 * (F/P) * \text{AFN-47}$$

Where, F= Output Frequency and P= the Number of Motor Poles

**DRV-15: Target/Output Frequency Display**

DRV▶TAR 0.00Hz  
15 OUT 0.00Hz

Factory Default: 0.00Hz

This parameter shows the Command (Target) Frequency set in DRV-00 and the drives Output Frequency. Can also display RPM’s, see DRV-17.

**DRV-16: Reference/Feedback Frequency Display**

DRV▶REF 0.00Hz  
16 FBK 0.00Hz

Factory Default: 0.00Hz

Appears only when ‘Yes’ is selected in APP-02 (PI Mode). This parameter shows the Reference and PI Feedback signals while in PID operation. The default units are in Hertz (Hz).

The units of the Reference and PI Feedback signal (APP-06) are selected with parameter I/O-86.

Ex1) When [mBar] is set

DRV▶REF 500mBa  
16 FBK 82.1mBa

Ex2) When [kPa] is set

DRV▶REF 500kPa  
16 FBK 82.1kPa

**DRV-17: Hz/Rpm Display**

DRV▶ Hz/Rpm Disp  
17                    0 Hz

Factory Default: 0 Hz

Set this parameter to [Hz] to display frequency, or to [Rpm] to display speed on main display, DRV-00 and other parameters with units of [Hz].

**DRV-18: PID Parameter (To monitor PID controller's Reference/Feedback value and Drive's Command/Output frequency)**

This parameter displays the PID controller's reference (set point) and the feedback value on the left side of the display. It also displays the drive's commanded and output frequency. All values are displayed in Hz (default), the feedback value will be displayed in percent [%] unit.

R 50.00HzT 45.3Hz  
F 8.24% O 0.5Hz

**DRV-19: AD Parameter (To monitor the AD conversion value of Analog input)**

This parameter displays the "raw" A to D (Analog to Digital converter) values of the analog inputs used for Freq mode, PID or Ext. PID reference/feedback. The readings are in raw A/D "counts". The A/D range is 0 to 4096 counts. Typically for a 0->10V input: 0V ~ 0 counts and 10V ~ 4096 counts.

Ex) When using V1 and I

V1        274    V2        0  
V1S        0    I        103

**DRV-20: EXT-PID Parameter (To monitor ExtPID controller's reference/ feedback/ output value)**

Displays ExtPID controller's reference/ feedback/ output value.

When APP-80 [Ext. PID operation selection] is set to "YES," reference and feedback are displayed in Percent unit.

When the PI Feedback signal (APP-06) and units (I/O-86) are selected, the reference and feedback values will be displayed by percent [%] unit.

R 50.00%O 45.32%  
F 8.24% DRV 20

**DRV-21 ~ DRV-23: Step Frequency 1 ~ 3**

DRV▶ Step freq-1  
21                    10.00 Hz

Factory Default: 10.00 Hz

DRV▶ Step freq-2  
22                    20.00 Hz

Factory Default: 20.00 Hz

DRV▶ Step freq-3  
23                    30.00 Hz

Factory Default: 30.00 Hz

The drive outputs the preset frequencies set in these parameters according to the programming and the state of the multi-function terminals configured as 'Speed-L', 'Speed-M', 'Speed-H' and 'Speed-X'. The output frequencies are determined from the binary combination of M1~M3. The frequency setting method of 'Speed 0' is determined by DRV-04.

See I/O-21~ 27 descriptions for Step Freq 4~7.

Binary Input Combination			Output Frequency	Step Speed
Speed-L	Speed-M	Speed-H		
0	0	0	DRV-00	Speed 0
1	0	0	DRV-21	Speed 1
0	1	0	DRV-22	Speed 2
1	1	0	DRV-23	Speed 3

**Note: Speed 0 is the set value from source DRV-04.**

**DRV-24: Output Current**

This parameter displays the individual phase output currents and the average of all phases as It (total).

la= 0A lb= 0A  
lc= 0A It = 0A

**DRV-26: Keypad Reference Mode**

DRV▶ KeyRefMode  
26 Disable

This parameter selects the mode of operation of the drive when the keypad is removed.

DRV-26	Description
Minimum Spd	The drive continues to run at the minimum speed, FUN-34.
Last Spd	The drive continues to run at the last speed, when keypad was removed.
Preset Spd 1	The drive continues to run at Preset Spd- 1 (DRV-21).
Stop	The drive stops according to Stop Mode setting, FUN-23.
Fault	The drive cuts off its output and when keypad is reconnected, displays Keypad FLT.
Disable (default)	Keypad Reference Mode is Disabled.

**Note: This function only operates when DRV-03 and DRV-04 are set to Keypad.**

**DRV-27: Current, Phase U  
DRV-28: Current, Phase V  
DRV-29: Current, Phase W  
DRV-30: Current, Ground**

DRV▶ Ia Current  
27 0.0 A

DRV▶ Ib Current  
28 0.0 A

DRV▶ Ic Current  
29 0.0 A

DRV▶ Ground Curr  
30 0.0 A

These parameters display the individual phase currents and ground current.

**DRV-91: Drive Mode 2**

Factory Default: Fx/Rx-1

This parameter provides the user a second start source to be selected by a digital input. This is often used with a local / remote selector switch. To use this function, one of the digital inputs must be set to [Loc / Rem]. When the input is closed, the second set of starting parameters is selected in DRV-91. When the input is open; the drive uses the starting parameters in DRV-03.

**DRV-92: Frequency Mode 2**

Factory Default: Keypad-1

This parameter provides the user a second frequency source to be selected by a digital input. This is often used with a local / remote selector switch. To use this function, one of the digital inputs must be set to [Loc / Rem]. When the input is closed, the second set of frequency parameters is selected in DRV-92. When the input is open the drive uses the frequency parameters in DRV-04.

**NOTES:**



### 6.2 Function Group [FUN]

#### FUN-00: Jump to Desired Parameter

FUN▶ Jump code  
00 1

Factory Default: 1

Jumping directly to any parameter can be accomplished by programming the desired parameter number.

#### FUN-01: Run Prevention

FUN▶ Run prev.  
01 None

Factory Default: None

This parameter allows the user to lockout forward or reverse operation of the motor. This function may be used for loads that rotate only in one direction such as fans and pumps.

LCD	Description
None	Forward & Reverse run available. (Factory default)
Forward Prev	Forward run prohibited.
Reverse Prev	Reverse run prohibited.

#### FUN-02: Acceleration Pattern FUN-03: Deceleration Pattern

FUN▶ Acc. pattern  
02 Linear

Factory Default: Linear

FUN▶ Dec. pattern  
03 Linear

Factory Default: Linear

This parameter determines the shape of the accel / decel ramp.

LCD Setting Range	Description
-------------------	-------------

LCD Setting Range	Description
Linear	The shape of the ramp is a straight line. (Factory default)
S-curve	The shape of the ramp is curved at the beginning and the end. The actual acceleration and deceleration time takes longer- about 40% than the time set in DRV-01 and DRV-02. This setting prevents shock during acceleration and deceleration, and prevents objects from moving on conveyors or other moving equipment.
U-curve	This pattern provides more efficient control of acceleration and deceleration in typical winding machine applications.

**Note:** Depending on the setting of this parameter the exact values in DRV-01 and DRV-02 may not represent the actual accel or decel times.

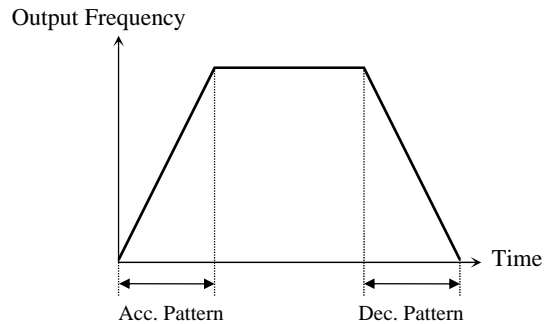

Accel/Decel Pattern: 'Linear'

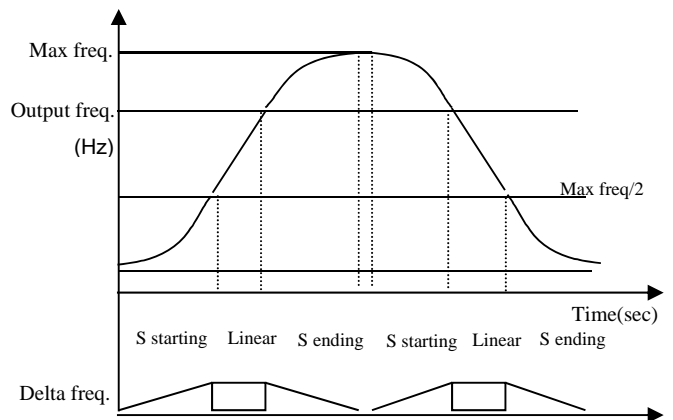

Accel/Decel Pattern: 'S-curve'

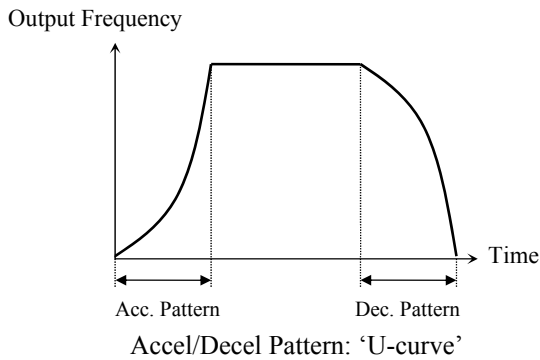

**FUN-04: Start Curve for S-Curve Accel/Decel Pattern**  
**FUN-05: End Curve for S-Curve Accel/Decel Pattern**

FUN ▶ Start Curve  
 04 50%

Factory Default: 50 %

FUN ▶ End Curve  
 05 50%

Factory Default: 50%

These parameters change the curvature of the acceleration and deceleration ramps. They also affect the actual acceleration and deceleration times by the following formulas:

$$\text{Actual accel time} = \text{Preset accel time} + \text{Preset accel time} * \frac{\text{Starting curve ratio}}{2} + \text{Preset accel time} * \frac{\text{Ending curve ratio}}{2}$$

$$\text{Actual decel time} = \text{Preset decel time} + \text{Preset decel time} * \frac{\text{Starting Curve ratio}}{2} + \text{Preset decel time} * \frac{\text{Ending curve ratio}}{2}$$

**FUN-10~12: Pre-heat**

FUN ▶ Pre-HeatMode  
 10 No

Factory Default: No

This function allows the drive to apply low levels of DC current to the motor to prevent moisture from entering and condensation from occurring inside the motor when stopped. When active, the display shows DCB in the status field.

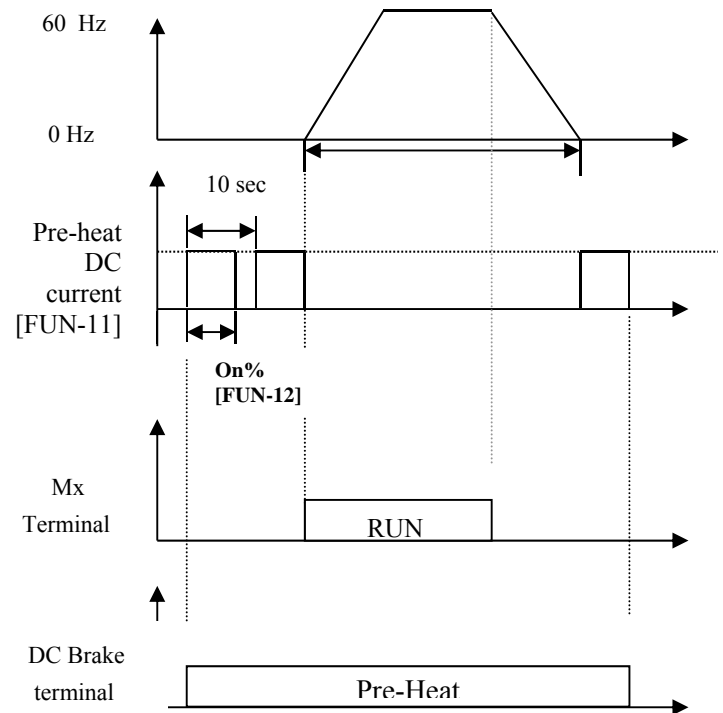

The Pre-heat function is activated when FUN-10 [Pre-heat] is set to "Yes" and one of the multi-function input terminals (I/O-20~27) is set to the "Pre-heat" function. The Preheat function is only active when the drive is stopped and the defined terminal is activated.

FUN▶PreHeatLevel  
11            30%

Factory Default:    30%

FUN-11 [Pre-heat value] is set in percent of motor rated current. Adjustment range is 1% to 50%.

FUN▶PreHeatPerc  
12            100%

Factory Default:    100%

FUN-12 [Pre-heat duty] sets the duty cycle for a 10 second interval. At 100% setting, DC current is continuously supplied to the motor. Adjustment range is 1% to 100%.

Note: Because the drive is operating, many parameters cannot be changed when the pre-heat function is active. Remove the reference command at the terminal to turn off the pre-heat function before attempting to adjust parameters.

**CAUTION** ⚠  
If the pre-heat current or duty cycle is set too high motor overheating may result. Reduce FUN-11 [Pre-heat value] or FUN-12 [Pre-heat duty] if the inverter or motor becomes overheated.

**FUN-20: Start Mode**

FUN▶ Start Mode  
20            Accel

Factory Default:    Accel

This parameter sets the starting method of the drive.

FUN-20 Setting Range	Function description
Accel	Acceleration to start (Factory default)
Dc-start	Drive starts acceleration after magnetizing DC current (see FUN-21 and FUN-22)
Flying-start	Drive matches the speed and starts into a rotating motor. See AFN-22.

**FUN-21: Starting DC Magnetizing Time  
FUN-22: Starting DC Magnetizing Value**

FUN▶ DcSt time  
21            0.0 sec

Factory Default:    0.0 sec

FUN▶ DcSt value  
22            50 %

Factory Default:    50 %

When FUN-20 is set to DC-start, the drive will output the amount of dc current set in FUN-22 for the amount of time set in FUN-21. The purpose of these parameters is to stop a freewheeling motor before starting. The drive will start accelerating after the amount of time in FUN-21.

FUN-22 [Starting DC Magnetizing Value] is the amount of DC Current applied to the motor and is set as percent of DRV-05 [Motor Rated Current].

**Note:** Do not set FUN-22 [Starting DC Magnetizing Value] higher than Inverter Rated Current. Otherwise, Motor Overheating or an Overload Trip may occur.

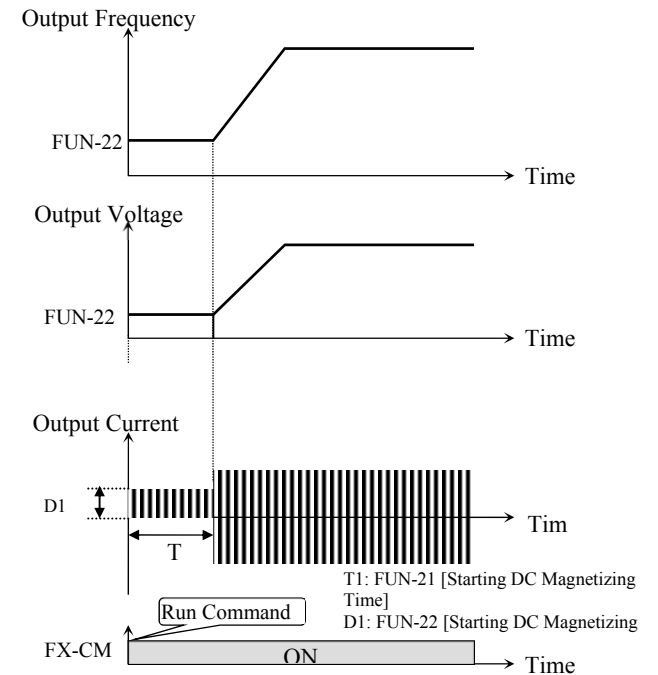

Note: DC-start is disabled when FUN-21 or 22 is set to “0”.  
Note: DC-start is deactivated in Sensorless mode.

**FUN-23: Stop Mode**

FUN▶ Stop mode  
23 Decel

Factory Default: Decel

This parameter sets the stopping method of the drive.

LCD Setting Range	Description
Decel	The drive stops using the deceleration pattern.
Dc-brake	The drive stops with DC injection braking. The drive will output a DC voltage when the frequency goes below the DC injection braking frequency during deceleration.
Free-run (Coast to stop)	The drive stops outputting voltage immediately when the stop signal is commanded.
Flux brake	Faster stopping times are available by converting some of the regenerating energy into heat at the motor during deceleration. Flux Brake will stop the motor as fast as possible without tripping the drive.

**⚠ Caution:** When DC braking or Flux braking is used, discretion must be used as excessive motor heating may result if the load inertia is large, if the braking is done frequently, if the brake current is set too high, or if the brake time is set too long.

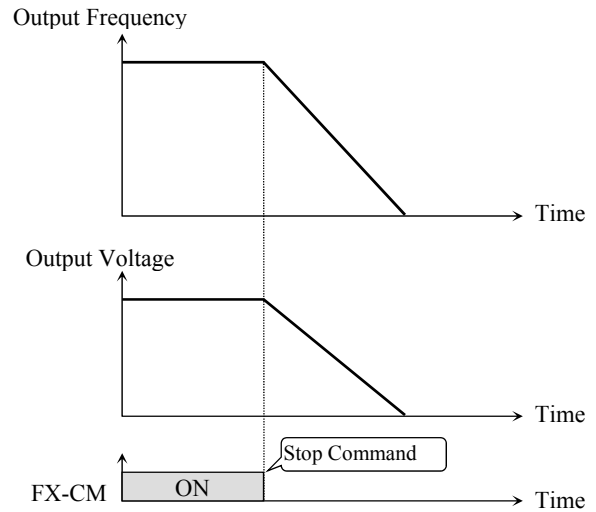

Stop Mode: Decel

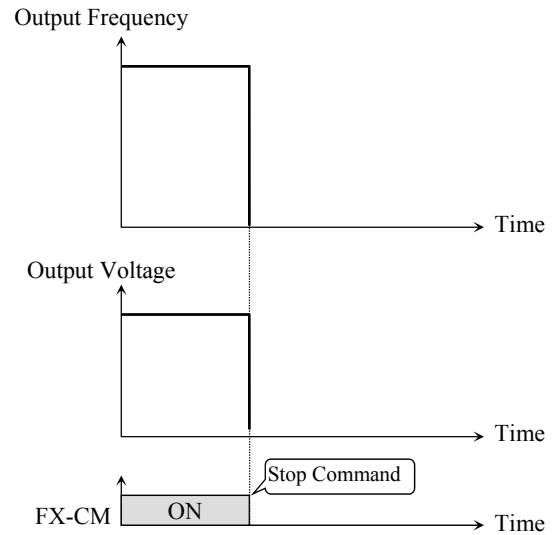

Stop Mode: Free-run

FUN-24: DC Injection Braking Delay Time  
 FUN-25: DC Injection Braking Frequency  
 FUN-26: DC Injection Braking Time  
 FUN-27: DC Injection Braking Value

FUN►DCBr dly tim  
 24 0.10 sec

Factory Default: 0.10 sec

FUN► DcBr freq  
 25 5.00 Hz

Factory Default: 5.00 Hz

FUN► DcBr time  
 26 1.0 sec

Factory Default: 1.0 sec

FUN► DcBr value  
 27 50 %

Factory Default: 50 %

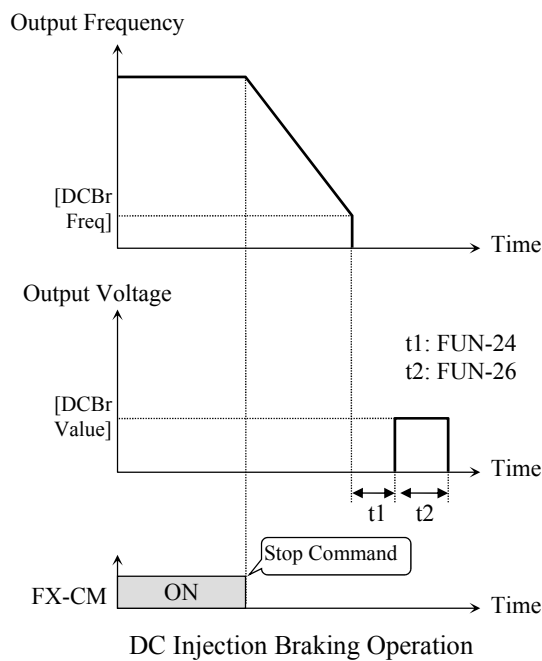

DC injection braking may be used to stop the motor more quickly than stopping by deceleration. This function is activated by selecting DC-brake in FUN-23.

The drive will decelerate to the frequency set in FUN-25. Upon reaching that frequency, the drive will wait the amount of time set in FUN-24. After waiting the amount of time in FUN-24, the drive will output the amount of voltage in FUN-27 for the amount of time in FUN-26.

FUN-24 [DC Injection Braking Delay Time] is the amount of time the drive waits before outputting voltage after the drive has gone below the frequency in FUN-25.

FUN-25 [DC Injection Braking Frequency] is the frequency at which the drive will start to output DC voltage during deceleration.

FUN-26 [DC Injection Braking Time] is the time that the DC current is applied to the motor.

FUN-27 [DC Injection Braking Value] is the DC current applied to the motor and is based on DRV-05, Rated Current of Motor.

**Caution:** Do not set the value of FUN-27 too high as it may cause the motor to overheat or the drive to overload trip.

**Note:** Do not set FUN-25 [DC Braking Frequency] too high. Otherwise excessive drive tripping may occur.

**FUN-28: Safety Stop**

FUN► Safety Stop  
 28 No

Factory Default: No

This function allows the drive to stop by decelerating the load upon loss of line power or a brownout condition. It can be very important to control the decelerating motor when power is lost depending on the application (for example to prevent check valve slamming in a pump system). The drive will use the regenerative energy from the motor and load to keep itself powered as it decelerates the motor under full

control to a safe stop. See parameters AFN-46 (Load Inertia), AFN-52 (Decel Rate) and AFN-53 (Decel Percentage) to fine tune the operation of this function.

**Note:** This function can only be applied to applications that have a high enough inertia to provide enough stored energy to complete the deceleration profile. Deceleration time will depend on available load inertia.

If line power returns and the drive has a valid run command the drive will accelerate the load back to its appropriate speed. There is a delay of 2 – 3 seconds after line power has returned before the drive will respond. If a Stop command is made, the drive will coast to a stop.

**FUN-29: Line Frequency**

FUN▶ Line Freq  
29 60.00 Hz

Factory Default: 60.00 Hz

This parameter sets the value of the incoming line frequency.

**Caution:** This parameters will affect the settings of other parameters such as Max frequency, Base frequency, and Upper limit. To set these related frequencies differently than the line frequency, the user should set these parameters manually AFTER setting FUN-29.

**FUN-30: Maximum Frequency**  
**FUN-31: Base Frequency**  
**FUN-32: Starting Frequency**

FUN▶ Max freq  
30 60.00 Hz

Factory Default: 60.00 Hz

FUN-30 [Maximum Frequency] is the highest frequency the drive will output.

FUN▶ Base freq  
31 60.00 Hz

Factory Default: 60.00 Hz

**CAUTION!**

**Consult with the motor manufacturer before exceeding the base speed of the motor. Verify that the driven equipment can operate at the maximum speed set.**

FUN-31 [Base Frequency] is the frequency where the drive outputs full motor rated voltage. This parameter is normally set to 50Hz or 60Hz. When using a 60Hz motor, set this parameter to 60Hz.

FUN▶ Start freq  
32 0.50 Hz

Factory Default: 0.50 Hz

FUN-32 [Starting Frequency] is the frequency where the drive starts to output voltage. For example, if FUN-32 it is set to 5Hz, the drive starts running when the reference frequency is 5 Hz.

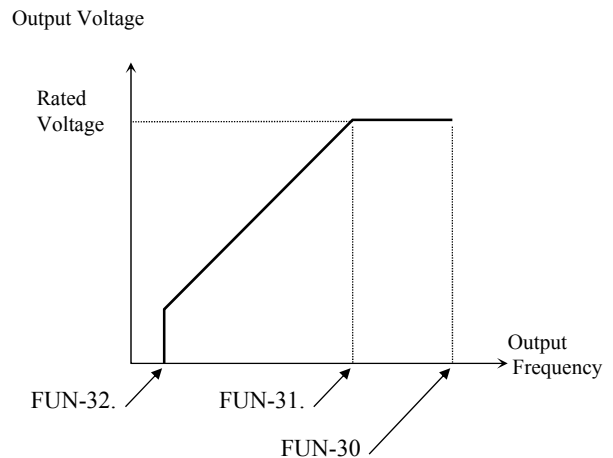

**Caution:** Note that these functions are reset when FUN-29 [Line Frequency] is set.

**Caution:** Note that improper setting of FUN 31 [Base Frequency] can cause overload trips and lack of motor torque.

**FUN-33: Frequency Limit Selection**  
**FUN-34: Low Limit Frequency**  
**FUN-35: High Limit Frequency**

FUN▶ Freq limit  
 33 No

Factory Default: No

FUN▶ Lim Lo Freq  
 34 0.50 Hz

Factory Default: 0.50 Hz

FUN▶ Lim Hi Freq  
 35 60.00 Hz

Factory Default: 60.00 Hz

When FUN-33 is set to Yes, it allows the user to set high and low limits for the drive. The drive will operate at the upper or the lower limit when the frequency reference is outside the frequency limit range.

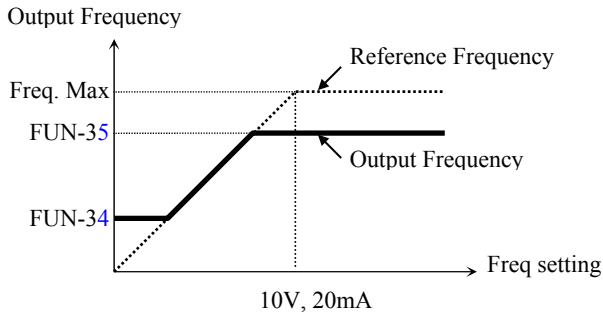

Freq. limit: Yes

**Note:** If the frequency reference is below the frequency low limit, the drive will operate at the low limit.

**FUN-40: Volts/Hz Pattern**

FUN▶ V/F pattern  
 40 Linear

Factory Default: Linear

This is the pattern of voltage/frequency ratio. Select the proper V/F pattern according to the load. The motor torque is dependent on this V/F pattern.

**[Linear]** pattern is used for constant torque loads. This pattern maintains a linear volts/frequency ratio from zero to base frequency. This pattern is appropriate for applications that require high starting torque. The performance will be improved with the help of AFN-67~69 [Torque boost].

**[Square]** pattern is used for variable torque loads such as fan and pumps. This pattern maintains a “squared” volts/hertz ratio and will increase energy savings in variable torque applications.

**[User V/F]** pattern is used for special applications. Users can adjust the volts/frequency ratio according to their application. This is accomplished by setting the frequency and voltage at four points between starting frequency and base frequency. The four points of voltage and frequency are set in FUN-41 through FUN-48.

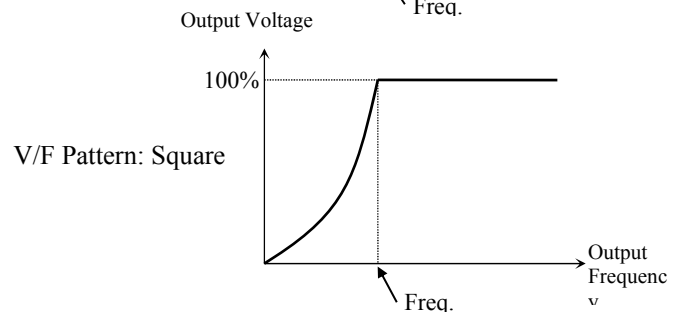
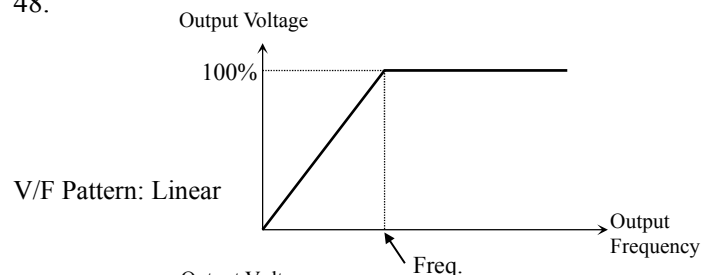

**FUN-41 ~ FUN-48: User V/F Frequency and Voltage**

FUN▶ User freq 1  
41           15.00 Hz

Factory Default: 15.00 Hz

FUN▶ User volt 1  
42           25 %

Factory Default: 25 %

- 
- 

FUN▶ User freq 4  
47           60.00 Hz

Factory Default: 60.00 Hz

FUN▶ User volt 4  
48           100 %

Factory Default: 100 %

These functions are available only when ‘User V/F’ is selected in FUN-40 [V/F pattern]. Users can make a custom V/F pattern by setting four points between FUN-32 [Starting Frequency] and FUN-31 [Base Frequency].

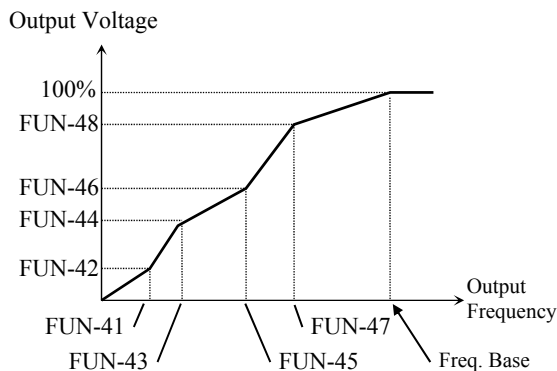

User V/F

**Note:** When the ‘User V/F’ is selected, the torque boost of AFN-67 through AFN-69 is ignored.

**FUN-49: AC Input Voltage Adjustment**

FUN▶ VAC 460.0V  
49           100.0 %

Factory Default: 100.0 %

230V models display VAC 230.0V (default)  
460V models display VAC 460.0V (default)  
600V models display VAC 575.0V (default)

The actual input voltage should be measured and the percentage calculated based on the following:  
% = Measured Input / default x 100%

Parameter	Display	Default	Setting
FUN-49	AC Input Volt	100 [%]	73 – 115 [%]

**Note:** It is very important to set this parameter correctly as this parameter affects the drive’s LV trip (low voltage trip) level and is also used by the Sensorless Vector control algorithm.

**FUN-50: Motor Rated Voltage**

FUN▶ Motor Volt  
50           460 V

Factory Default: 230V, 460V, 575V  
Model Dependant

This parameter sets the actual motor rated voltage. This information can be found on the motor nameplate. The drive will automatically adjust its output voltage to compensate for any input voltage fluctuations.

If this parameter is set to 0V the drive will automatically detect the incoming voltage and use the incoming voltage level as the motor rated voltage. Use caution when setting this value to 0V (auto), as the drive may not always sense the proper input voltage, if the input voltage is too high.

**Note:** When the actual input voltage is less than FUN-50 [Motor rated voltage] the maximum output voltage will be equal to the input voltage.



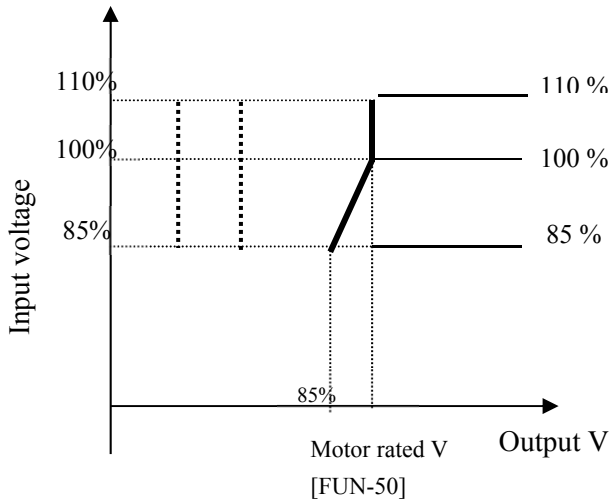

**FUN-51~52: Energy Save, Energy Save Level**

FUN▶ Energy save  
51                      None

Factory Default:    0

FUN▶ Manual save%  
52                      0 %

Factory Default:    0 %

This function is used to reduce the output voltage in applications that do not require high torque and current when running at steady speed. The drive will reduce its output voltage after accelerating to the reference frequency (steady speed) if the energy save level is set at a non-zero value.

**CAUTION** ⚠  
**This function may cause over-current trips to occur due to the lack of output torque when used on a fluctuating load. If the manual energy saver value is reduced too much, the applied motor voltage may be too low for correct motor operation and motor stalling and/or overheating may result.**

**Note:** When Energy Save is ON, it may take longer to decelerate to a stop.

FUN-51 Setting Range	Description
None	Disabled (Factory setting)
Manual	Energy save ON by decreasing the output with the value set in FUN-52.
Auto	Energy save ON automatically.

Param	LCD	Name	Default	Range
FUN-52	Manual Save %	Energy save %	0 [%]	0~30 [%]

**FUN-54: Integrating Wattmeter**

This parameter displays both MWh and kWh.  
Ex) 1500kWh

FUN▶ Kilowatts  
54 1M 500.0KWh

Max Cumulative value is displayed in FUN-54 as shown below.

Ex) 9,999,999.9 kWh (maximum reading)

FUN▶ Kilowatts  
54 9999M999.9KWh

Press [PROG] key for 5 sec to reset the value stored in FUN-54.

Note: FUN-54 values may differ from the actual values slightly due to measurement tolerance issues.

**FUN-55: Inverter temperature**

FUN▶ Inv. Temp  
55                      44

Factory Default:    44

The power section's temperature (in Celsius) is displayed in FUN-55.

**FUN-56: Motor temperature**

FUN▶ Motor Temp  
56 0

Factory Default: 0

The Motor temperature (in Celsius) detected by an externally connected thermal sensor is displayed in FUN-56. See I/O-98 for more description.

**FUN-57: No Motor Sel**  
**FUN-58: No Motor Level**  
**FUN-59: No Motor Time**

FUN▶ No Motor Sel  
57 No

Factory Default: No

FUN▶ NoMotorLevel  
58 25 %

Factory Default: 5

FUN▶ NoMotorTime  
59 3.0 sec

Factory Default: 3.0 sec

**Low Output Current Level Detection**

With FUN-57 set to “Yes”, these parameters can be used to generate a trip when the output current is below a set level (FUN-58) for a period of time (FUN-59). The current level is based on the set Motor rated current, DRV-05. A “HW-Diag” fault will occur displaying the message “No Motor Trip”.

**No Motor Connection**

These parameters can be used to detect an open output contactor or disconnect switch between drive output and the motor.

Description	LCD Display	Setting Range
No Motor Selection	No Motor Sel	No/Yes
Trip Current Level	No Motor Level	5 – 100 [%]
Trip Time Setting	No Motor Time	0.5 – 10.0 [sec]

**FUN-64: Overload Warning Level**  
**FUN-65: Overload Warning Time**

FUN▶ OL level  
64 110 %

Factory Default: 110 %

FUN▶ OL time  
65 10.0 sec

Factory Default: 10.0 sec

One of the auxiliary relay outputs must be configured as “OL” (parameters I/O-76 through I/O-79) to activate OL Warning. The drive will then generate an alarm signal (contact closure) and the display will flash “OL Warning” when the output current has reached the FUN-64 [Overload Warning Level] for the FUN-65 [Overload Warning Time]. The alarm signal will continue for the FUN-65 time even if the current has fallen below the FUN-64 current level.

**Note: FUN-64 is set as the percentage of DRV-05 [Rated Motor Current].**

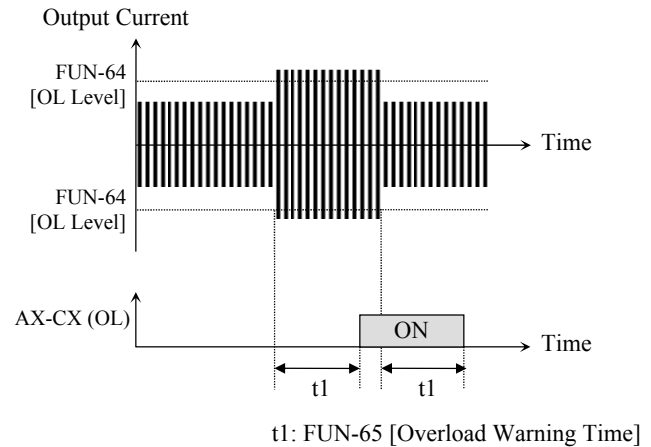

Overload Warning

**FUN-66: Overload Trip Selection**  
**FUN-67: Overload Trip Level**  
**FUN-68: Overload Trip Delay Time**

FUN▶ OLT select  
 66 --- No ---

Factory Default: No

FUN▶ OLT level  
 67 120 %

Factory Default: 120 %

FUN▶ OLT time  
 68 60.0 sec

Factory Default: 60.0 sec

When set to “yes”, the drive will trip and display a fault message when the output current persists over the FUN-67 [Overload Trip Level] for the time of FUN-68 [Overload Trip Time]. This function protects the drive and motor from abnormal load conditions. The drive cannot be reset immediately after an overload trip. A cool down period of approximately one minute is required prior to resetting the drive.

**Note:** The set value is the percentage of DRV-05 [Rated Motor Current].

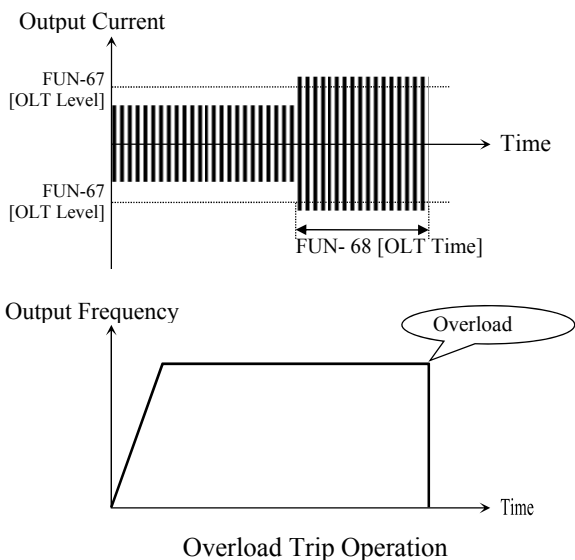

**FUN-69: Input/Output Phase Loss Protection (Bit Set)**

FUN▶ Trip select  
 69 001

Factory Default: 001

This function will cause the drive to trip upon a phase loss or opening. Phase loss detection can be selected for the input as well as the output.

**FUN-69 [Phase Loss Protection Mode Selection]**

Setting Range			FUN-69	Description
Bit 2	Bit 1	Bit 0		
0	0	1	001	Output phase loss protection active
0	1	0	010	Input phase loss protection active
1	0	0	100	Phase loss protection during exchange operation active

**Bit 0: Output phase loss protection Enable/Disable**

0: Disabled for Output phase loss protection.  
 1: Enabled for Output phase loss protection. The drive will fault upon loss of output phase.

**Bit 1: Input phase loss protection Enable/Disable**

0: Input phase loss protection disabled.  
 1: Input phase loss protection enabled. The drive will shut down and stop upon loss of input phase.

**Bit 2: Protection Enable/Disable selection at Exchange function**

0: Disabled at Exchange function (Inverter-Commercial line exchange).  
 1: Enabled at Exchange function.

**FUN-70: Stall Prevention Mode**  
**FUN-71: Stall Prevention Level**

FUN▶ Stall prev.  
 70 No

Factory Default: No

FUN▶ Stall level  
 71 100 %

Factory Default: 100 %

This function is used to prevent the motor from stalling by reducing the drive output frequency until the motor current decreases below the stall prevention level. When enabled (FUN-70 set to “yes”), this function is active for all modes of operation: acceleration, steady speed, and deceleration.

**Note:** FUN-71 is set as the percentage of DRV-05 [Rated Motor Current].

**Note:** When enabled, the maximum level will be limited to 120% of Inverter rated Current.

**Note:** The stall level will be automatically reduced if the drive is operated at the frequency higher than base frequency.

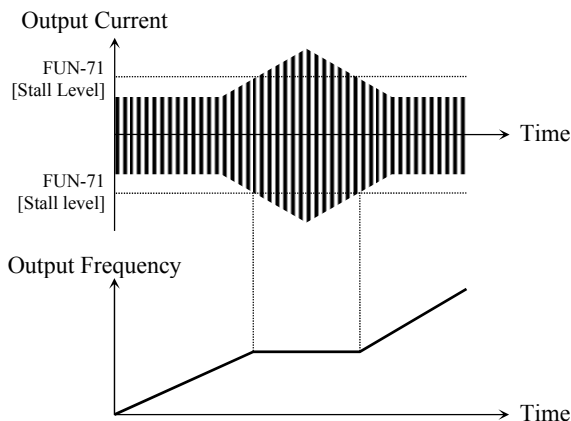

Stall Prevention during Acceleration

**Note:** The actual Acceleration time may extend due to stall prevention during Acceleration.

**Note:** The drive starts deceleration when a Stop command is applied even while a motor stall state is present.

**Note:** The output frequency and hence the motor speed may oscillate due to stall prevention action during constant run mode.

**Note:** The actual deceleration time (i.e. the time for the motor to slow down or stop) may lengthen due to stall prevention.

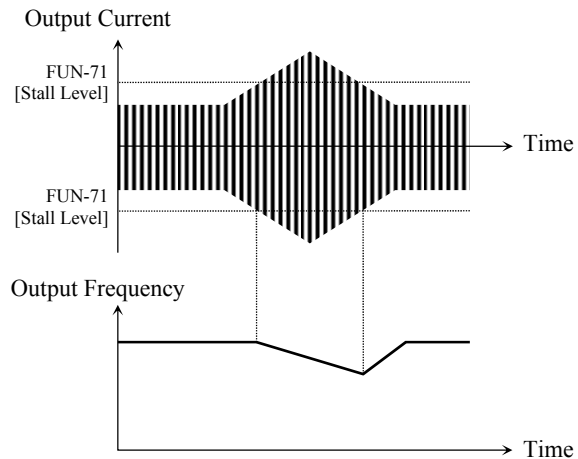

Stall Prevention during Constant Run

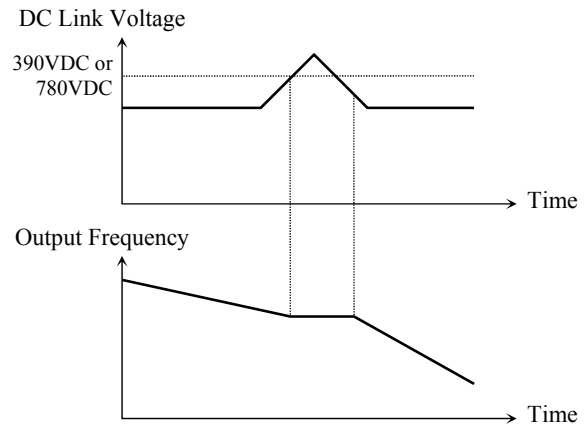

Stall Prevention during Deceleration

**FUN-72: Accel/Decel Change Frequency**

FUN▶Acc/Dec ch F  
72            0.00 Hz

Factory Default: 0.00 Hz

This function is used to change Accel/Decel ramps at a certain frequency. The drive will ramp the speed to FUN-72 using I/O-50 (Acceleration Time1). At that point it will switch to DRV-01 (Acceleration Time). Likewise, upon deceleration, the drive will use DRV-02 (Deceleration Time) until the drive reaches FUN-72, where it will switch to I/O-51 (Deceleration Time 1).

**Note:** If Accel/Decel change frequency is set and ‘XCEL-L’, XCEL-M’, and XCEL-H’ defined in multi-function terminals are ON, Multi Accel/Decel operation has the priority.

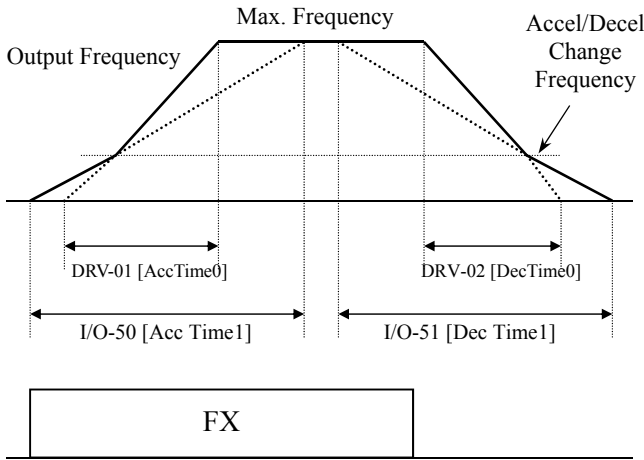

Accel/Decel Change Operation

**FUN-73: Reference Frequency for Accel/Decel**

FUN▶Acc/Dec freq  
73            Max

Factory Default: Max

This parameter determines the reference for the Accel / Decel times. For most applications, the Max freq. setting is appropriate.

LCD Setting Range	Description
Max freq	The Accel/Decel time is the time that takes to reach the maximum frequency from 0 Hz.
Delta freq	The Accel/Decel time is the time that takes to reach a target frequency from any frequency.

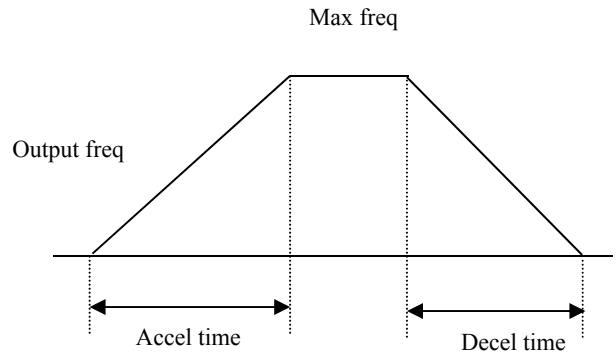

FUN-73: Max. Freq

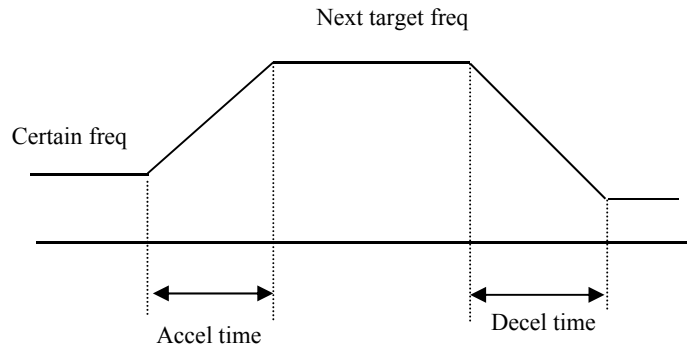

FUN-73: Delta Freq

**FUN-74: Accel/Decel Time Scale**

FUN▶ Time scale  
74      0.1 sec

Factory Default: 0.1 sec

This parameter is used to change the number of significant digits displayed for the Accel and Decel parameters. It also affects the time scale (maximum range) of the acceleration and deceleration times.

LCD Setting Range	Description
0.01 sec	The Accel/Decel time is changed by 10 msec. The maximum setting range is 60 seconds.
0.1 sec	The Accel/Decel time is changed by 100 msec. The maximum setting range is 600 seconds.
1 sec	The Accel/Decel time is changed by 1 sec. The maximum setting range is 6000 seconds.

**FUN-75: Up/Down Save Mode**

FUN▶ UpDnSaveMode  
75      No

**FUN-76: Up/Down Save Frequency**

FUN▶ UpDnSaveFreq  
76      0.00 Hz

These parameters are used in conjunction with the digital input terminals (I/O-20 ~ I/O-27) when set to Up and Down (EMOP) control. The saved frequency (FUN-76, view only) is the frequency at the time the input terminal (Up/Down) is released (deactivated). Enable the Up/Down Save mode with FUN-75 set to “yes”. The saved frequency can be cleared with a digital input set to “Up/Dn Clr”.

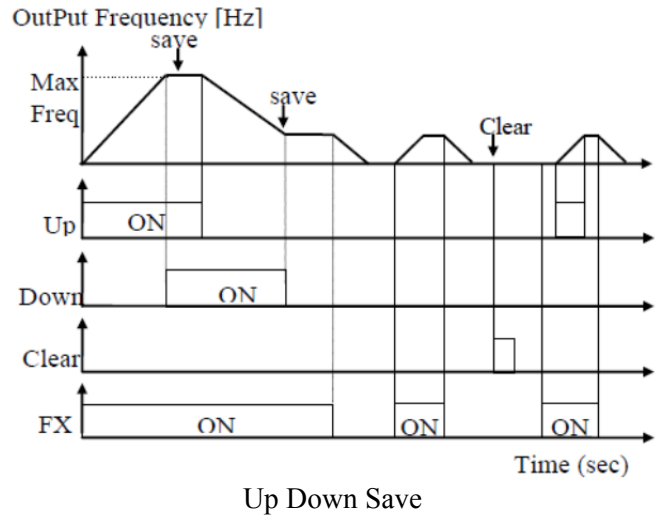

**FUN-80: Over Heat Warning Level**

FUN▶ OH Warn Levl  
80      90%

This parameter is used to activate an auxiliary relay when set to “OH Warn” with parameters I/O-76~I/O-79. The percentage is based on an Over Heat Fault occurring at 100%. The actual trip temperature is based on the drives internal thermistor(s) and varies depending on horse power rating of drive.

FUN-81: Analog Stall Source  
 FUN-82: Current Limit Level

FUN▶ AnaStall Src  
 81                   None

FUN▶Max Ana Perc  
 82                   100%

When FUN-70 (Stall Mode) is set to “yes” user can select a remote variable source (I, V1, Pulse) to limit current instead of a fixed level (FUN-71). The FUN-82 percentage is at the maximum of the analog signal (FUN-81).

FUN-81 Setting Range	Description
None	Uses FUN-71 level.
I	0(4)-20 mA signal used for current limit.
V1	0-10V signal used for current limit.
Pulse	0-100kHz signal used for current limit.

Ex) FUN-81 set to “V1”, 0 - 10V scale  
 FUN-82 set to 150% (10V = 150%)  
 With 5V input at V1:

**Stall level = 150% x 5V/10V = 75%**  
 Current is limited to 75% of DRV-05, motor amps.

The calculated stall level is displayed in FUN-71.

**NOTES:**



### 6.3 Advanced Function Group [AFN]

#### AFN-00: Jump to Desired Parameter

AFN▶ Jump code  
00 1

Factory Default: 1

Jumping directly to any parameter can be accomplished by programming the desired parameter number.

- AFN-01: Last trip 1
- AFN-02: Last trip 2
- AFN-03: Last trip 3
- AFN-04: Last trip 4
- AFN-05: Last trip 5
- AFN-06: Erase Trips

AFN▶ Last trip-1  
01 None

Factory Default: None

AFN▶ Last trip-5  
05 None

Factory Default: None

These parameters display the past five faults of the drive. AFN-01 is the most recent fault. Use the **PROG**, **▲** and **▼** keys to check the fault log content. Output frequency, output current, drive temperature, DC Link Voltage and the mode of operation when the fault occurred, are displayed. Press the **ENTER** key to exit. AFN-83 [Last Trip Time] is the elapsed time after the last trip.

**Note:** Faults such as WDOG error, EEP error, and ADC Offset, HW-Diag are not resettable. Repair the fault before turning on the power.

AFN▶ Erase trips  
06 --- No ---

Factory Default: No

This function erases all fault histories of AFN-01 to AFN-05 from memory. However, AFN-83 [Last Trip Time] cannot be reset.

#### AFN-07: Dwell Time AFN-08: Dwell Frequency

AFN▶ Dwell time  
07 0.0 sec

Factory Default: 0.0 sec

AFN▶ Dwell freq  
08 5.00 Hz

Factory Default: 5.00 Hz

When a run command is initiated, the drive will ramp to the dwell frequency and remain there for the dwell time.

**Note:** If the dwell time is set at '0', this function is not available.

**Note:** Do not set the Dwell frequency above the frequency command. Otherwise, it may lead to incorrect operation.

**Note:** This function is disabled when operating in Sensorless control mode.

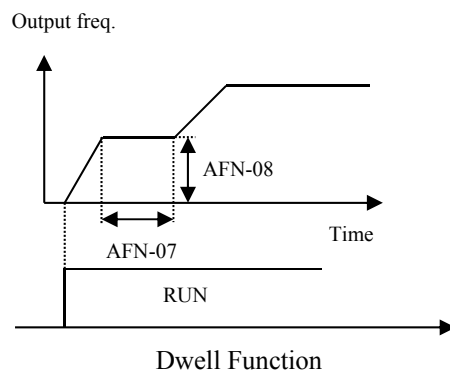

**AFN-10 ~ AFN-16: Frequency Jump**

AFN▶ Jump freq  
10 --- No ---

Factory Default: No

AFN▶ jump Lo 1  
11 10.00 Hz

Factory Default: 10.00 Hz

AFN▶ jump Hi 1  
12 15.00 Hz

Factory Default: 15.00 Hz

- 
- 
- 

AFN▶ jump Lo 3  
15 30.00 Hz

Factory Default: 30.00 Hz

AFN▶ jump Hi 3  
16 35.00 Hz

Factory Default: 35.00 Hz

These parameters allow the user the ability to lock out certain frequencies that can cause resonance in the driven equipment. Three different jump frequency ranges may be set. The drive will accelerate and decelerate through the jump frequencies, but will not be allowed to sit at the locked out frequencies.

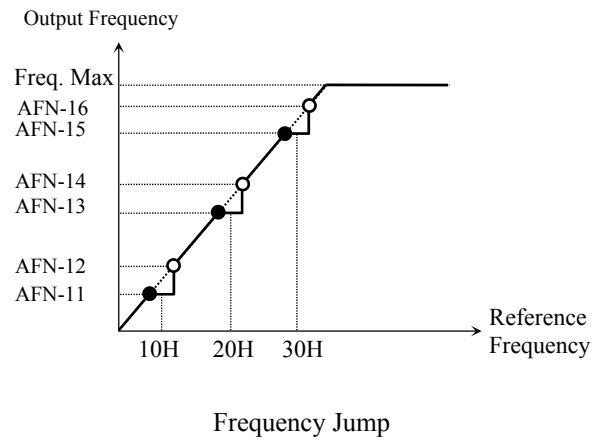

**Note:** When the reference frequency is set between the jump frequency low/high limit, it follows the low limit frequency, marked by “●”.

**Note:** If jump range 1 and range 2 are overlapped, the lower freq. will become a low limit.

**AFN-20: Power ON Start Selection**

AFN▶ Power-on run  
20 No

Factory Default: No

If AFN-20 is set to 'No', upon loss of power, the user will be required to open the run command and then close the run command to restart the drive. **If AFN-20 is set to 'Yes', and the run command remains closed, the drive will restart after power is restored.** The drive will start at its normal starting frequency and accelerate normally based on its settings. If the motor is still rotating when power is restored, the drive may trip. To avoid this trip, use 'Speed Search' function (AFN-22).

**CAUTION**  
Careful attention must be directed to this function as the motor will start to run immediately upon applying AC input power.

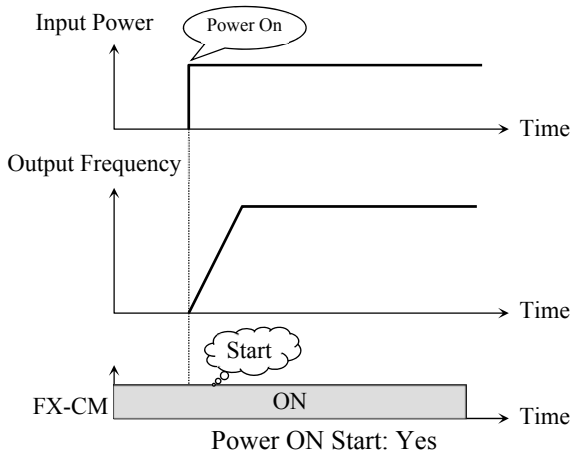
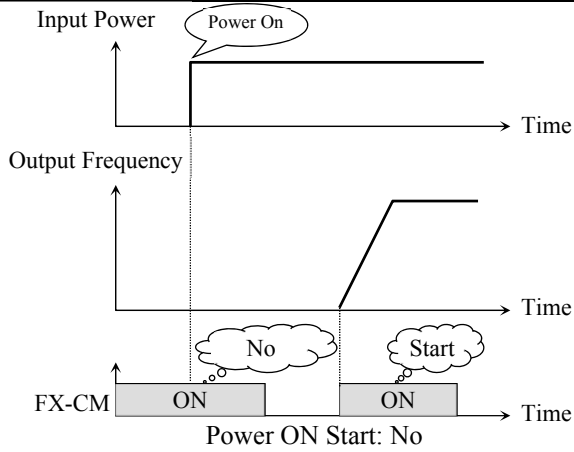

**Note:** When setting 'Power ON Start' to 'Yes', make sure to use appropriate warning notices and safety interlocks to minimize the potential for injury or equipment damage.

**AFN-21: Restart After a Fault Reset**

AFN▶ RST restart  
21 No

Factory Default: No

If AFN-21 is set to 'No', upon resetting a fault, the user will be required to open the run command and then close the run command to restart the drive. **If AFN-21 is set to 'Yes', and the run command remains closed, the drive will restart after the fault is reset.** The drive will start at its normal starting frequency and accelerate normally based on its settings. If the motor is still rotating when power is restored, the drive may trip. To avoid this situation, use 'Speed Search' function (AFN-22).

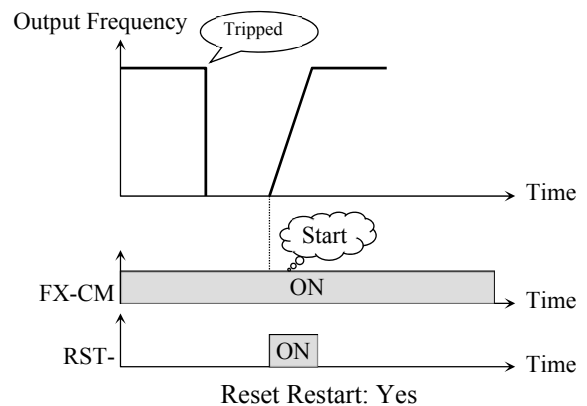
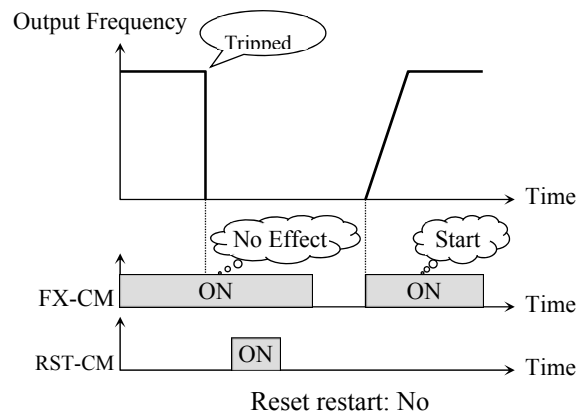

**AFN-22: Restart after Instantaneous Power Failure  
AFN-23: Speed Search**

AFN▶ IPF Mode  
22 No

Factory Default: No

AFN▶ estimated SS  
23

Factory Default: estimated SS

This function is used to permit automatic restarting into a spinning motor after an Instantaneous Power Failure. When AFN-22 is set to “yes”, the Speed Search function is activated regardless of FUN-20 (Start Mode) setting. AFN-20 (Power On Run) must also be set to “yes” and the run command active (Fx closed) to perform the Speed Search Flying Start. See also AFN-27, Flying Percentage and AFN-46, Inertia Rate.

Speed Search synchronizes the drive output (Voltage, Frequency, and Direction) to that of the spinning motor. This is accomplished by sweeping the output frequency from the reference frequency down while increasing the output voltage from zero up.

**Note:** Speed search during Acceleration can also be independently activated by setting FUN-20 [Start Mode] to “Flying Start”.

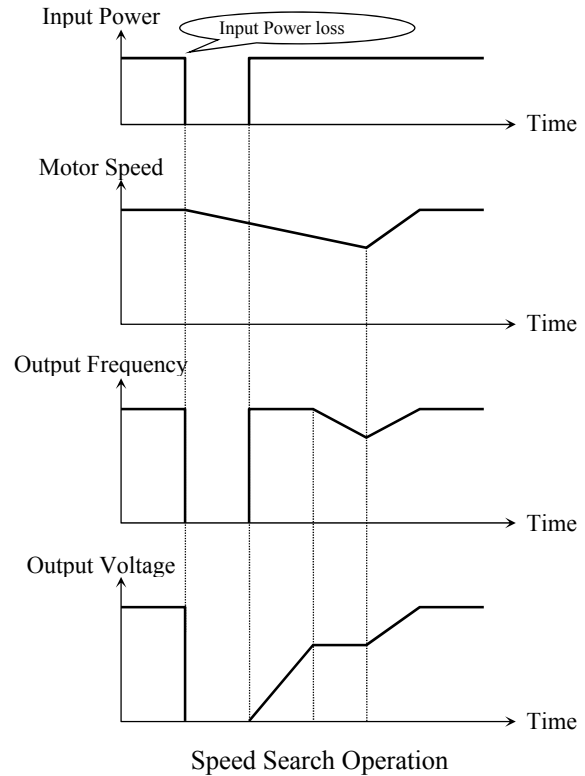

**AFN-24: Auto Fault Reset  
AFN-25: Number of Auto Retry  
AFN-26: Delay Time Before Auto Retry**

AFN▶ Retry Mode  
24 No

AFN▶ Retry number  
25 0

AFN▶ Retry delay  
26 1.0 sec

When AFN-24 is set to “yes” the drive has the ability to automatically reset itself after a fault occurs. The drive will reset itself up to the number of times set in AFN-25. The drive will wait the amount of time set in AFN-26 after a fault before attempting a restart. The motor may be coasting when the restart occurs. To catch the spinning load, use the speed search function, AFN-22.

Some faults cannot be automatically reset. These include Low Voltage (LV) trip, Inverter Disable (BX) and OC-2 Output Short circuit.

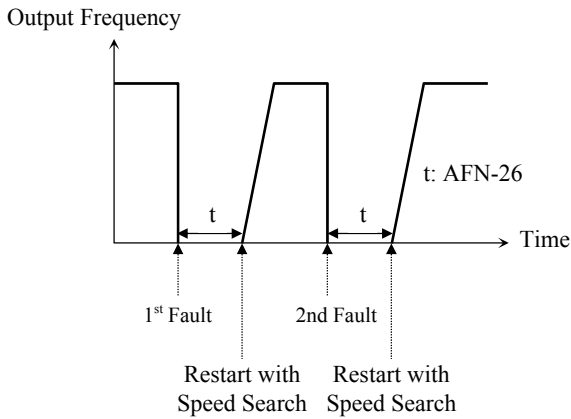

**Note:** The drive decreases the retry number by one as each fault occurs. If a trip does not occur after the drive is running for 30 seconds, the drive increases the retry number by one until it reaches the amount in AFN-25.

**⚠ CAUTION**

Careful attention must be directed to this function as the motor restarts automatically after a fault is reset.

**AFN-27: Flying Percentage**

AFN▶ Flying Perc  
27                      70%

This parameter limits the output current during Speed Search/Flying Start. Percentage is based on DRV-05, Motor Amps.

- AFN-40: Motor Capacity Selection
- AFN-41: Number of Motor Poles
- AFN-42: Rated Motor Slip
- AFN-44: No Load Motor Current
- AFN-45: Motor Efficiency
- AFN-46: Load Inertia

If the user does not set these values, the drive will use factory default values.

AFN▶ Motor select  
40                      7.5HP

Factory Default: 7.5 HP  
Model Dependant

This parameter sets the motor capacity. The following parameters are automatically set according to motor capacity.

- AFN-42 Rated Motor Slip
- DRV-05 Rated Motor Current (Recheck DRV-05 after changing HP setting).
- AFN-44 No Load Motor Current
- AFN-62 Stator Resistance
- AFN-63 Rotor Resistance
- AFN-64 Leakage Inductance

If AFN-44 [Motor No-load Current] is not correct, run the drive without the load in V/F mode and check the current at the constant run state and enter this value to AFN-44 [No load current].

AFN▶ Pole number  
41                      4

Factory Default: 4

This is used to display the motor speed. If you set this value to 2, the drive will display 3600 rpm instead of 1800 rpm at 60Hz output frequency. (See motor nameplate)

AFN▶ Rated-Slip
42            2.34 Hz

Factory Default:    2.34 Hz Automatically set according to the motor capacity (AFN-40)
---

This is used in ‘Slip Compensation’ control, AFN-60. If you set this value incorrectly, the motor may stall during slip compensation control (See motor nameplate).

Motor rated slip freq [Hz] =  
(Rated input freq. [Hz] – (Motor rpm \* P/120))  
P: Number of motor poles

**(Ex) In the case of 60Hz, 4 pole, 1760 rpm motor**  
Motor rated slip freq [Hz] = (60[Hz]-(1760[rpm] \* 4/120))  
= 60[Hz]-58.67[Hz] =1.33[Hz]

AFN▶ No-load-Curr
44            6.6 A

Factory Default:    6.6 A Automatically set according to the motor capacity (AFN-40)
---

If this value is not right, check the current after operating in V/F mode without a load connected and enter that current value.

**Note: Verify the correct value for AFN-44 [Motor No-load Current]. Otherwise, the Sensorless vector control may not operate properly.**

**Note: The default motor parameters may differ with the actual motors used. In this case, enter the nameplate value of your motor to the corresponding parameters. If the motor rating exceeds the drive capacity, poor performance may result.**

AFN▶ Efficiency
45            86 %

Factory Default:    86 % Automatically set according to the motor capacity (AFN-40)
--

The value of this parameter is used for calculating the output wattage when AFN-81 is set to ‘Watt’.

AFN▶ Inertia rate
46            10

Factory Default:    10
------------------------

This parameter is used by many drive functions such as Sensorless Vector control [AFN-60], Speed Search [AFN-22], and Safety Stop [FUN-28]. When using these functions, the inertia value can be fine tuned to provide better performance. The available range is 1 to 40. Set to low numbers for loads that have low load inertias for a quicker search time. Set to higher numbers for loads that have high load inertias for a slower search time.

During Speed Search operation, if overvoltage trips occur increase the value of this parameter and retest.

During Safety Stop operation, if undervoltage trips occur then decrease the value of this parameter. If overvoltage trips occur increase the value of this parameter and retest. The higher the inertia setting the slower the deceleration rate is during Safety Stop operation.

### AFN-47: Gain for Motor Speed Display

AFN▶ RPM factor
47            100 %

Factory Default:    100 %
---------------------------

This parameter is used to change the motor speed display to rotating speed (r/min) or the load’s mechanical speed (m/min). The display is calculated by following equation:

$$\text{Rotating speed (r/min)} = 120 * F / P * \text{Motor RPM Display Gain [AFN-47]}$$

Where, F=Output frequency, P= motor pole number

**AFN-48: Carrier Frequency**

AFN▶ Carrier freq  
48            X.X kHz

Factory Default: Model Dependent

Param	LCD Display	Description	Setting Range
AFN-48	Carrier freq	Carrier Frequency	0.7 ~ 15 [kHz]

This parameter sets the switching frequency for the PWM output. The switching frequency will affect the audible sound of the motor, electrical interference from the drive, internal drive temperature, and leakage current. If the ambient temperature where the drive is installed is high or other equipment may be affected by potential electrical interference, set this value lower.

If this paramter is set above 10kHz, reduce the rated output current by 5% for each 1kHz above 10kHz. Do not set the carrier frequency below 1.5kHz when AFN-60 [Control mode selection] is set to Sensorless Vector, otherwise poor performance can result.

**Note:** AFN-48 [Carrier freq] setting range varies with inverter capacity.

**AFN-49: PWM Mode Selection**

AFN▶ PWM Select  
49            Low Leakage

Factory Default: Low Leakage

Electrical noise and leakage currents can be reduced by changing the PWM carrier characteristics without changing the PWM carrier frequency (AFN-48).

AFN – 49 Setting Range	Description
Normal	Operation via standard Space Vector PWM pattern. PWM frequency may be automatically adjusted at low speed for optimal performance.
Low Leakage	Space Vector PWM pattern to reduce leakage currents.

**Note:** Reducing the PWM carrier frequency may increase audible motor noise.

**Note:** The carrier frequency cannot be set below 2.0 kHz if low leakage (default) is selected in AFN-49.

**AFN-52: Decel Rate  
AFN-53: Safety Stop Output**

AFN▶ Dec Rate  
52            100 secs

AFN▶ safety\_perc  
53            21

These parameters are used in conjunction with FUN-28, Safety Stop (when active) to control the stopping of the motor upon a loss of power. The decel rate (secs.) should be set to the amount of time the motor takes to coast to a stop under normal conditions. The safety percentage is the percentage that the output voltage is decreased when safety stop is activated. For low inertia loads, increase the percentage to lower the output voltage. This helps the drive maintain the DC Bus voltage for a longer period of time.

**AFN-60: Control Mode Selection**

AFN▶Control mode  
60 V/F

Factory Default: V/F

Selects the control mode of the drive.

AFN-60 Setting	Description
V/F	V/F Control
Slip compensation	Slip compensation
Sensorless	Sensorless vector control speed operation

**◆ V/F control:**

This parameter provides a constant voltage/frequency ratio. It is recommended for most general-purpose applications. To increase the starting torque with this method, increase the torque boost function.

Related function: AFN-67~69 [Torque boost]

**◆ Slip compensation:**

This function is used to maintain a constant motor speed, even with varying loads. To keep the motor speed constant, the actual output frequency will change in response to varying loads. The amount of frequency that the load varies is limited by the Rated Slip, (AFN-42). For example, when the motor speed decreases below the reference speed (frequency) due to a heavy load, the drive increases the output frequency higher than the reference frequency to increase the motor speed. The drive increases or decreases the output by the delta frequency shown below.

$$\text{Delta freq (Slip Comp. Freq.)} = \text{Motor Rated slip} * (\text{Output current} - \text{Motor No load current}) / (\text{Motor rated current} - \text{Motor No load current})$$

$$\text{Output freq} = \text{Reference freq} + \text{Delta freq}$$

Motor parameters AFN-41~46 and DRV-05 are automatically determined by AFN-40 [Motor selection]. The default settings are typically acceptable; however the parameters may be fine-tuned if necessary. **AFN-40~46, DRV-05 [Motor related parameters for Slip Compensation]**

Param	LCD Display	Description
AFN-40	Motor select	Select motor capacity
AFN-42	Rated-Slip	Motor rated slip (Hz)
DRV-05	Rated-Curr	Motor rated current (rms)
AFN-44	Noload-Curr	Motor no load current (rms)
AFN-45	Efficiency	Motor efficiency (%)
AFN-46	Inertia rate	Motor inertia rate

**Note: Incorrectly setting AFN-44 [Motor No-load Current] may degrade the Sensorless Vector control performance.**

**◆ Sensorless Vector speed control operation:**

Use sensorless vector control when 1) high starting torque is required at low speeds 2) the load fluctuates 3) fast torque response times are needed.

For proper operation set AFN-40~46, DRV-05 [Motor parameters] and AFN-60 [Control mode select] properly.

Set “Yes” in AFN-61 [Auto tuning] first before using this control.

**Related parameters: AFN-40~46, DRV-05, AFN-60, AFN-62~66**

Parameter	LCD display	Parameter
AFN-62	RS	Stator resistance
AFN-63	Lsigma	Leakage inductance
AFN-65	SL P-gain	Sensorless P gain
AFN-66	SL I-gain	Sensorless I gain

**Guide for Optimal Use of Sensorless Vector Control**

For optimum use of sensorless vector control, the following conditions should be met. If one of the following conditions is not satisfied, the drive and motor may not work properly due to insufficient torque, cogging, or excessive motor noise. In any of the following situations are not satisfied, it is recommended to use V/F Control or Slip Compensation control instead of sensorless vector control.

- ▣ The motor capacity should be equal to or one horsepower level lower than the drive capacity.



- ▣ The drive should only use one set of motor parameters. The drive should not be set to use the second set of motor parameters.
- ▣ For best performance, the auto tuning feature in AFN-61 should be used.
- ▣ Set the appropriate values for the overload limit function and the stall prevention. The values set should exceed 100% of the rated motor current.
- ▣ When using analog signals to control the speed of the drive, the wires should be shielded and installed to reduce electrical interference.
- ▣ The number of motor poles should be 2, 4 or 6.
- ▣ The distance between the drive and the motor should not exceed 100m (328 ft).

**CAUTIONS WHEN USING SENSORLESS VECTOR CONTROL**

- ▣ Forced-cooling should be used for the motor when the average operating speed is under 20Hz and more than 100% load is applied.
- ▣ The motor may rotate 0.5% faster than the maximum speed under light loads or if the motor temperature does not reach normal operating temperature.
- ▣ Use the auto-tuning feature when the motor is at normal temperature (average temperature where the motor normally operates).
- ▣ The output torque may be reduced when an output filter option is used between the drive and the motor.
- ▣ Overcurrent trips may occur if AFN-62 [Stator resistance] is set to more than double the auto-tuned value.

**Additional Tuning for Sensorless Vector Control**

- ▣ Adjust the AFN-44 [No Load Motor Current (RMS)] value larger or smaller by 5% if the measured current is higher or lower than that of V/F control when under a light load.
- ▣ Adjust the AFN-42 [Rated Motor Slip] value larger or smaller by 5% if the actual speed is faster or slower than that of V/F control with rated load.

**AFN-61~63: Auto tuning**

AFN▶ Auto tuning
61 NO

Factory Default: NO
---------------------

All of the motor parameters can be tuned by setting AFN-61 to “YES”. Auto tuning is deactivated when “No” is selected.

The auto tuning function automatically measures the motor parameters needed for Sensorless Vector control and Auto Torque Boost such as stator resistance, rotor resistance, leakage inductance and no-load current.

**Note: The rated current, voltage, efficiency and slip described in the motor nameplate should be entered before performing auto tuning. If efficiency is not indicated on the nameplate, use the default value.**

AFN▶ Stator Resistance
62 Rs

AFN▶ Leakage Inductance
63 Lσ

These parameters display default settings based on motor horse power, set with parameter AFN-40. When Sensorless Vector control is selected in AFN-60, and Auto tuning is performed with AFN-61, the values detected during auto tuning are displayed.

**AFN-64: Pre-excitation Time**

AFN▶ PreExTime  
64            1.0 sec

Factory Default: 1.0 sec

When the start command (FWD or REV) is issued, the drive will pre-excite the motor automatically for the time specified by this parameter. This function is used in order to fully magnetize the motor so that full torque can be produced immediately upon starting the motor.

After AFN-64 [Pre-excitation Time] elapses the drive will start normal operation as shown in the following graph.

Param	LCD display	Factory setting	Setting range
AFN-64	PreExTime	1 [sec]	0 ~ 60 [sec]

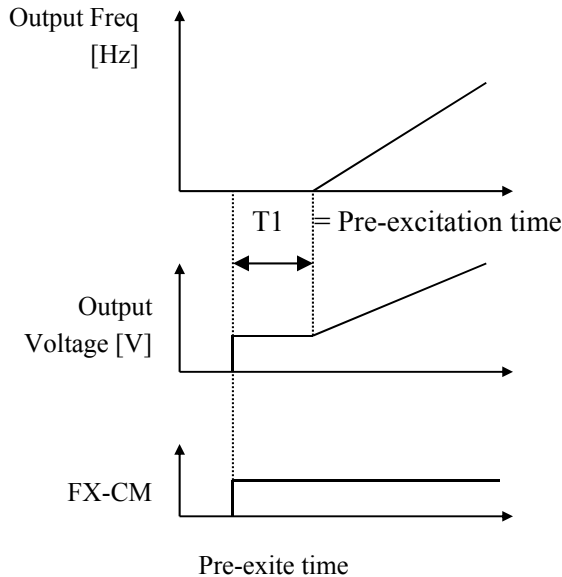

**AFN-65: P Gain for Sensorless Control  
AFN-66: I Gain for Sensorless Control**

AFN▶ SL P-gain  
65            3000

Factory Default: 3000

SL P-gain is the proportional gain of the speed loop controller during Sensorless Vector control. If this value is set high, you can get fast speed response characteristics. However, if this value is set too high, the steady state characteristics may become unstable. The default settings are typically acceptable, and this parameter should only be changed to increase the performance of the system.

AFN▶ SL I-gain  
66            1000

Factory Default: 1000

SL I-gain is the integral gain of the speed loop controller during Sensorless Vector control. If this value is set low, you can get better transient response characteristics and steady state characteristics. However, if this value is set too low, there may be an overshoot in speed control. The default settings are typically acceptable, and this parameter should only be changed to increase the performance of the system.

**Note:** The response time of a system is affected by the load inertia. For better control performance, set AFN-46 [Load Inertia] correctly.

AFN-67: Manual/Auto Boost Selection  
 AFN-68: Torque Boost in Forward Direction  
 AFN-69: Torque Boost in Reverse Direction

AFN▶ Torque boost  
 67 Manual

Factory Default: Manual

AFN▶ Fwd boost  
 68 2.0 %

Factory Default: 2.0 %

AFN▶ Rev boost  
 69 2.0 %

Factory Default: 2.0 %

These functions are used to increase the starting torque at low speeds by increasing the output voltage of the drive. If the boost value is set higher than required, it may cause the motor flux to saturate causing an over-current trip. Increase the boost value when there is excessive distance between drive and motor to compensate for  $I^2R$  losses in the wires.

**Manual Torque Boost**

When AFN-67 [Manual/Auto torque boost select] is set to “Manual”, AFN-68 [Forward torque boost] and AFN-69 [Reverse torque boost] set values are applied.

Param	LCD display	Default	Range
AFN-67	Torque boost	Manual	Manual/Auto
AFN-68	Fwd boost	2 [%]	0~15 [%]
AFN-69	Rev boost	2 [%]	0~15 [%]

**Note:** The torque boost value is set as the percentage of the drives rated voltage.

**Note:** When FUN-40 [Volts/Hz Pattern] is set to ‘User V/F’ or when operating in Sensorless Vector Control mode, AFN-67~69 [Torque boost] is ignored.

**Note:** If the torque boost is set higher than needed, it is possible to over-flux or saturate the motor.

This can result in high currents, motor overheating, and over current trips.

**Auto Torque Boost**

When AFN-67 [Manual/Auto torque boost select] is set to “Auto”, the drive will increase the torque boost automatically to match the required load.

**Note:** Auto torque boost can only be applied to the 1<sup>st</sup> set of motor parameters. Only Manual torque boost is available for the 2<sup>nd</sup> set of motor parameters.

**Note:** Auto torque boost is not available when AFN-60 [Control Mode] is set to ‘Sensorless’.

**Note:** For proper operation, it is recommended to Auto Tune the motor before using the auto boost function. See AFN-61.

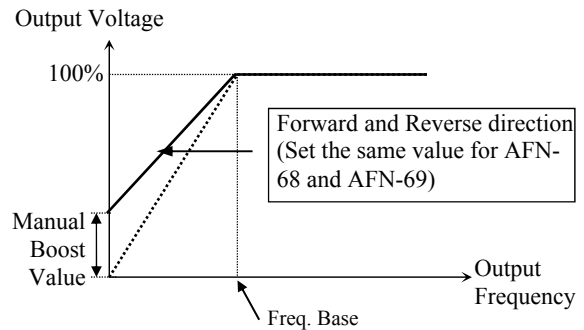

Constant Torque Loads: Conveyor, Moving Equip. etc.

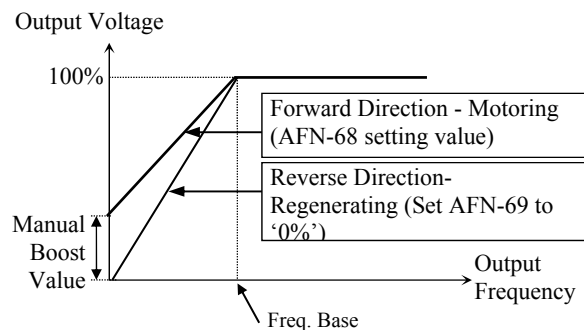

Ascending and Descending Loads: Parking, Hoist etc.

**Related Functions:** FUN-40 [Volts/Hz Pattern]  
 AFN-60 [Control Mode selection]

**AFN-80: Power On Display**

AFN▶ PowerOn disp  
80                    0

Factory Default: 0

This parameter selects which parameter will be displayed first on the keypad when the power is turned on.

Setting Range	Description
0	DRV-00 [Command Frequency]
1	DRV-10 [Output Current]
2	DRV-11 [DC Link Voltage]
3	DRV-12 [Power], Select with AFN-81
4	DRV-15 [Target/Output]
5	DRV-16 [Ref/Fdbk] when in PI Mode
6	DRV-18 [PI Parameters] when in PI Mode
7	DRV-20 [Ext-PID]
8	DRV-24 [Output Currents]
9	FUN-54 [KiloWattHour]
10	FUN-55 [Inverter Temperature]
11	AFN-84 [On Time]
12	AFN-85 [Run Time]

**AFN-81: User display selection**

AFN▶ User Disp  
81                    Voltage

Factory Default: Voltage

**Related Function:** DRV-12 [User display selection]

This parameter selects what function is to be displayed in DRV-12.

AFN-81 Setting Range	Name	Description
Voltage	Output voltage	Display the output voltage of the drive (Factory setting)
Watt	Output power	Display the output power of the drive

**AFN-82: Software Version**

AFN▶ S/W Version  
82                    Ver 1.0

Factory Default: Ver. 1.0

This parameter displays the software version. This will vary depending on software version installed in the drive. Version 1.0 and later applies to new control board.

**AFN-83, 84, 85: Last Trip Time, On-time, Run-time**

AFN▶ LastTripTime  
83 0:00:00:00:00

Factory Default: 0:00:00:00:00

Displays time elapsed after the last trip occurs.

**Note:** Time is reset automatically after each trip.

AFN▶ On-time  
84 0:00:00:00:00

Factory Default: 0:00:00:00:00

This parameter displays the total time that the drive has had input power applied.

AFN▶ Run-time  
85 0:00:00:00:00

Factory Default: 0:00:00:00:00

This parameter displays the total time that the drive has been operating. Pre-heat time is included in this reading.

**FUN-83~85 display → X : XX : XX : XX : XX  
(Year:Month:Day:Hour:Minute)**

**AFN-87: Output Power Display Adjustment**

```
AFN▶ Power set
87      100%
```

Factory Default: 100%

Used to adjust the drive output power display (AFN-81, DRV-12) and the KiloWattHour display (FUN-54).

**AFN-90: Parameter Display**

```
AFN▶ Para. disp
90      Default
```

Factory Default: Default

This parameter selects which parameters can be viewed by the user.

AFN-90 Setting Range	Description
Default	Displays basic parameters. (factory default)
All Para	Displays all parameters.
Diff Para	Displays parameters changed from default settings.

**AFN-91: Parameter Read  
AFN-92: Parameter Write**

```
AFN▶ Para. read
91 --- No ---
```

Factory Default: No

```
AFN▶ Para. write
92 --- No ---
```

Factory Default: No

These are useful for programming multiple drives that have the same parameter settings. The LCD keypad can read (upload) the parameter settings from the drive memory and can write (download) them to other drives. See related parameter AFN-95.

**Note:** When AFN-91, 92 is used, motor parameters such as DRV-05, AFN-40~46 and AFN-62~63 will be initialized.

1) Set AFN-91 to “Yes” and press Enter key to read the parameters. “Yes” will be displayed while reading. Display will change to “No” when completed.

```
AFN▶ Para. read
91 --- Yes ---
```

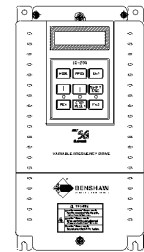

2) Take the LCD keypad out.

```
AFN▶ Para. write
92 --- Yes ---
```

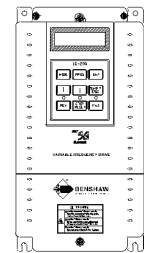

3) Install the keypad into the next drive and set AFN-92 to “Yes”. Then press Enter to download the parameters.

**NOTE:** The above Read/Write function can only be performed on drives with the same software. Check parameter AFN-82 for drive software version.

```
AFN▶ Para. Write
92   VER. Err
```

**VER. Err** is displayed if software is not the same version.

**AFN-93: Parameter Initialize**

AFN▶ Para. init  
93            No

Factory Default:    No

This is used to initialize parameters back to the factory default values. Each parameter group can be initialized separately or all parameters can be initialized at once.

**Note:** Set DRV-05 and AFN-40~46 [Motor parameters] again after this function.

**Note:** Parameter initialize cannot clear trip information. Instead, use AFN-06 [Erase trips].

LCD Setting Range	Description
No	Displayed after initializing is finished.
All Groups	All parameter groups initialized to factory default value.
DRV	Only Drive group initialized.
FUN	Only Function group initialized.
AFN	Only Advanced Function group initialized.
I/O	Only Input/Output group initialized.
APP	Only Application group initialized.

**AFN-94: Parameter Lock**

AFN▶ Para. lock  
94            0

Setting Range: 0 - 9999

This function is used to lock the parameters from being changed. Enter the password (four digits) registered in AFN-96, Password Register. When the parameters are locked, the display arrow changes from solid to dashed line. To Unlock, enter the same password (four digits) registered in AFN-96, Password Register. The display arrow changes from dashed line to solid.

**Note:** Speed Reference at the Keypad (DRV-04 set to Keypad) can be changed while parameters are locked.

**Note:** Parameter Initialize (AFN-93) cannot be performed when locked.

**AFN-95: Parameter Save (Manual Save)**

AFN▶ Para. save  
95            No

Setting AFN-95 to “Yes” causes the changed parameters to be saved to non-volatile memory. When programming multiple drives using the parameter read and write functions (AFN-91 and AFN-92) from one keypad, perform a parameter save prior to performing the first parameter read (AFN-91) to the keypad. Parameters are also saved when power is removed from the drive.

**AFN-96: Password Register**

AFN▶ PW Register  
96            0

Setting Range: 0 - 9999    0

This parameter is used to register a password (four digits). The registered password can now be used to lock (and unlock) the parameters using AFN-94. When parameters are locked, user cannot register another password.

## 6.4 Input/Output Group [I/O]

### I/O-00: Jump to Desired Parameter

I/O► Jump code  
00 1

Factory Default: 1

Jumping directly to any parameter can be accomplished by programming the desired parameter number.

### I/O-01 ~ I/O-05: Analog Voltage Input (V1) Signal Adjustment

These parameters are used to adjust the scaling of the V1 analog input signal. The scaling and slope of the analog signal is adjusted by setting parameters I/O-02 through I/O-05. A filter time (I/O-01) can also be set to reduce the affects of noise on the analog signal.

Parameter	Factory Default	Setting Range
I/O-01	10 msec	0~9999[msec
I/O-02	0 V	0 ~ 12V (or max of I/O-04)
I/O-03	0 Hz	0 ~ Max Freq
I/O-04	10 V	0 ~ 12 V
I/O-05	60 Hz	0 ~ Max Freq

I/O► V1 filter  
01 10 ms

Factory Default: 10 ms

This is the filtering time constant for V1 signal input. Increasing this value will reduce the drive's response to noise. However, increasing this parameter will also make the drive respond slower to speed changes.

I/O► V1 volt x1  
02 0.00 V

Factory Default: 0.00 V

This is the minimum voltage of the V1 input at which the drive will output minimum frequency (I/O-03).

I/O► V1 freq y1  
03 0.00 Hz

Factory Default: 0.00 Hz

This is the drives output minimum frequency (or target value) when there is the minimum voltage (I/O-02) on the V1 terminal.

I/O► V1 volt x2  
04 10.00 V

Factory Default: 10.00 V

This is the maximum voltage of the V1 input at which the drive will output maximum frequency (I/O-05).

I/O► V1 freq y2  
05 60.00 Hz

Factory Default: 60.00 Hz

This is the drives output maximum frequency (or target value) when there is the maximum voltage (I/O-04) on the V1 terminal.

Reference Frequency

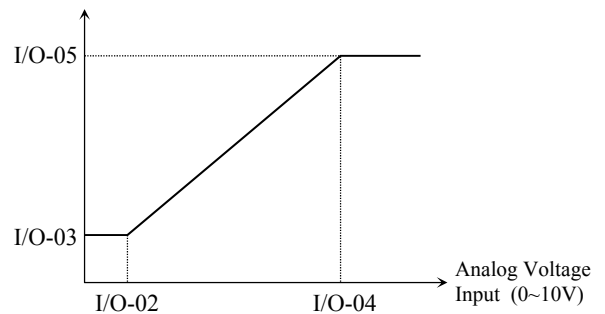

Reference Frequency vs. Analog Voltage Input (0 to 10V)

**I/O-06 ~ I/O-10: Analog Current Input (I) Signal Adjustment**

These parameters are used to adjust the scaling of the "I" analog input signal. The scaling and slope of the analog signal is adjusted by setting parameters I/O-07 through I/O-10. A filter time (I/O-06) can also be set to reduce the affects of noise on the analog signal.

Parameter	Factory Default	Setting Range
I/O-06	10 msec	0 ~ 9999 msec
I/O-07	4 mA	0 ~ 20mA (or max of I/O-09)
I/O-08	0 Hz	0 ~ Max freq
I/O-09	20 mA	0 ~ 20 mA
I/O-10	60 Hz	0 ~ Max freq

I/O► I filter  
06 10 ms

Factory Default: 10 ms

This is the filtering time constant for I signal input. Increasing this value will reduce the drive's response to noise. However, increasing this parameter will also make the drive respond slower to speed changes.

I/O► I curr x1  
07 4.00 mA

Factory Default: 4.00 mA

This is the minimum current of the 'I' input at which the drive outputs minimum frequency (I/O-08).

I/O► I freq y1  
08 0.00 Hz

Factory Default: 0.00 Hz

This is the drives output minimum frequency (or target value) when there is minimum current (I/O-07) input on the 'I' terminal.

I/O► I curr x2  
09 20.00 mA

Factory Default: 20.00 mA

This is the maximum current of the 'I' input at which the drive outputs maximum frequency (I/O-10).

I/O► I freq y2  
10 60.00 Hz

Factory Default: 60.00 Hz

This is the drives output maximum frequency (or target value) when there is the maximum current input (I/O-09) on the 'I' terminal.

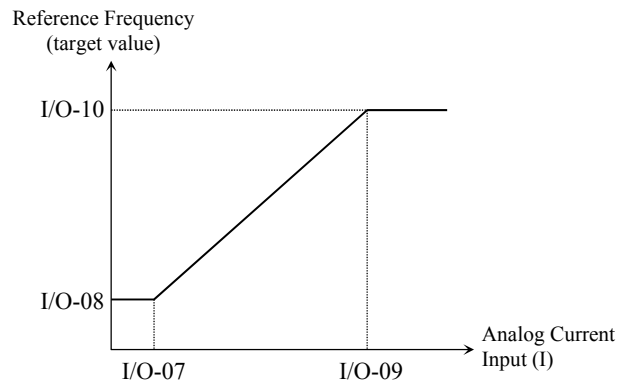

Reference Frequency vs. Analog Current Input (4 to 20mA)



**I/O-11~16: Frequency command setting via pulse (A0/B0)**

I/O▶ P pulse set  
11 (A)

Factory Default: (A)

I/O▶ P filter  
12 10 msec

Factory Default: 10 msec

I/O▶ P pulse x1  
13 0 KHz

Factory Default: 0.0 KHz

I/O▶ P freq y1  
14 0 Hz

Factory Default: 0.0 Hz

I/O▶ P pulse x2  
15 10.00 KHz

Factory Default: 10.0 KHz

I/O▶ P freq y2  
16 60.00 Hz

Factory Default: 60.00 Hz

These parameters are displayed when DRV-04 is set to Pulse. These parameters are used to configure a pulsed input.

Param	Factory setting	Setting range
I/O-11	(A)	(A), (A+B)
I/O-12	10 msec	0 ~ 9999 msec
I/O-13	0 KHz	0 ~ 10KHz
I/O-14	0 Hz	0 ~ Max frequency
I/O-15	10 KHz	10 ~ 100KHz
I/O-16	60 Hz	0 ~ Max frequency

**Note: Do not apply pulse to both A0, B0 terminals when I/O-11 set value is A.**

**Pulse Specification**

Term	HP	Setting Range
A0/B0	7.5 ~ 40	High: +3~+5V Max Low: +2V Max Max Input Freq.: 100KHz
A0/B0	50 ~ 700	High: +12+15V Max Low: +2.5V Max Max Input Freq.: 100KHz

**Note: Use Open Collector type encoder for Pulse input.**

Param	LCD Display	Description
I/O-11	P Pulse Set	Set one of the frequency setting input method either A or A+B.
I/O-12	P filter	Set the embedded filter constant for P Pulse input.
I/O-13	P Pulse x1	Set the Minimum frequency for P Pulse input.
I/O-14	P freq y1	Set the output frequency corresponding to P Pulse input minimum frequency (I/O-13).
	P [**] y1	Set the target value corresponding to P Pulse input minimum frequency (I/O-13)
I/O-15	P Pulse x2	Set the Maximum frequency for P Pulse input.
I/O-16	P freq y2	Set the output frequency corresponding to P Pulse input Maximum frequency (I/O-15).
	P [**] y2	Set the target value corresponding to P Pulse input maximum frequency (I/O-15)

**Note: Increase the filter time constant when the noise interference deteriorates stable operation. Increasing the time makes the response time slower.**

**Note:** When setting P Pulse Input Min/Max Freq. via motor encoder, set the value for encoder pulse per the following example:

**To give 60Hz (1800 rpm) command from 1000 Pulse encoder:**

I/O-15 [Max Freq of P Pulse Input] =  
 Rated rpm/60 sec \* Number of Encoder Pulse =  
 1800 [rpm]/60[sec] \* 1000 = 30000 Hz,  
 Therefore, set I/O-15 to 30 KHz

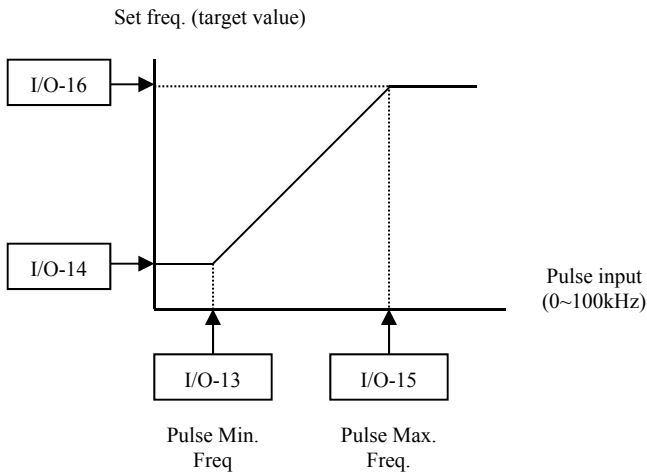

**I/O-17, 18, 19: Criteria for Analog Input Signal Loss**

I/O▶ Wire broken  
 17 None

Factory Default: None

I/O▶ Lost command  
 18 None

Factory Default: None

I/O▶ Time out  
 19 1.0 sec

Factory Default: 1.0 sec

I/O-17 sets the criteria for losing the analog input signal when DRV-04 [Frequency Mode] is set to 'V1', 'VIS' 'I', or 'Pulse'. This function does not operate when DRV-04 is set to V1 + I.

The following table describes the settings in I/O-17.

LCD Setting Range	Description
None	Disabled.
half of x1	The drive determines that the frequency reference is lost when the analog input signal is <u>less than half of the minimum</u> set value (I/O-02, I/O-07 or I/O-13).
below x1	The drive determines that the frequency reference is lost when the analog input signal is <u>less than the minimum</u> set value (I/O-02, I/O-07 or I/O-13).

I/O-18 [Operating method after loss of analog freq. command] selects the action the drive will take after losing the analog signal.

The following table describes the settings in I/O-18.

LCD Setting Range	Description
None	Continuous operation.
FreeRun	The driver shuts down by coasting to a stop.
Stop	The drive stops using its Decel pattern and Decel time.
Protection	The drive trips and displays Lost Cmd fault.

When the analog input signal is lost, the drive will display one of the following messages, as shown in the table below.

LCD Setting Range	Description
LOV	Loss of analog input signal, V1
LOI	Loss of analog input signal, I
LOA	Loss of pulsed reference frequency
LOR	Loss of communications reference frequency
Lost Cmd	Fault when I/O-18 is set to protection

I/O-19 [Time out] sets the delay time after the signal is lost before the drive determines loss of signal.

Parameter	Factory setting	Setting range
I/O-19	1.0 secs.	0.1 ~ 120 secs.

**I/O-20~27: Multi-function Input Terminal 'M1, M2, M3', 'M4', 'M5', 'M6', 'M7', 'M8' Define**

I/O▶ M1 define  
20 Speed-L

Factory Default: Speed-L

I/O▶ M2 define  
21 Speed-M

Factory Default: Speed-M

I/O▶ M3 define  
22 Speed-H

Factory Default: Speed-H

- 
- 
- 

The multi-function input terminals can be defined for many different applications. The following table shows the default settings for terminals M1 through M8.

Param	LCD display	Default	Setting
I/O-20	M1 define	SPEED-L	See the table to the right
I/O-21	M2 define	SPEED-M	
I/O-22	M3 define	SPEED-H	
I/O-23	M4 define	Reset	
I/O-24	M5 define	BX	
I/O-25	M6 define	JOG	
I/O-26	M7 define	FX	
I/O-27	M8 define	RX	

**Note:** BX is the Drive Disable function. When activated (On), parameter changing is disabled.

The following table shows the various functions that can be programmed (I/O-20 ~ I/O-27) for terminals M1 through M8.

LCD Setting Range	Description
Speed-L	Multi-step speed - Low
Speed-M	Multi-step speed - Mid
Speed-H	Multi-step speed - High
XCEL-L	Multi-accel/decel - Low
XCEL-M	Multi-accel/decel - Mid
XCEL-H	Multi-accel/decel - High
Dc-brake	DC injection braking during stop
2nd Func	Exchange to 2 <sup>nd</sup> functions
Exchange	Exchange to commercial line
-Reserved-	Reserved for future use
Up	Increase Speed
Down	Decrease Speed
3-Wire	3 wire operation
Ext Trip	External trip
Pre-heat	Motor Pre-heat function
iTerm Clear	Used for PID control
Open-loop	Exchange between PID mode and V/F mode
Loc / Rem	Local or Remote start control
Analog hold	Hold the analog command frequency input signal
XCEL stop	Disable Accel and Decel
P Gain2	Used for PID P2 gain control
-Reserved-	Reserved for future use
Interlock1	Used for MMC operation
Interlock2	
Interlock3	
Interlock4	
Speed-X	Additional Step frequency selection
Reset	Reset a fault
BX	BX (Drive Disable)
JOG	Jog
FX	Forward Run/Stop
RX	Reverse Run/Stop
Ana Change	Analog input Switch-over
Ext.PID Run	Ext PID Control On / Off
Up/Dn Clr	Clears the saved frequency when Up/Down functions are used.

**Note:** If any two terminals are programmed to the same function, the drive will display the flashing message “Over Lap”.

**I/O-28: Terminal Input Status**

I/O▶ In status  
28 000000000000

Factory Default: 000000000000

This parameter displays the input status of control terminals M1-M8. P4-P6 are for future use.

Input Term	P6	P5	P4	M8	M7	M6	M5	M4	M3	M2	M1
	10 bit	9 bit	8 bit	7 bit	6 bit	5 bit	4 bit	3 bit	2 bit	1 bit	0 bit
OFF status	0	0	0	0	0	0	0	0	0	0	0
ON status	1	1	1	1	1	1	1	1	1	1	1

**I/O-29: Multi-function input terminal filter time constant**

I/O▶ Ti Filt Num  
29 15 ms

Factory Default: 15 ms

Debounces and sets the responsiveness of input terminals M1-M8. Increasing the filter time is effective when noise level is high. Increasing this parameter will make response time slower and decreasing it will make response faster.

**Note:** Set the parameter higher than 100msec when attempting Inverter-Commercial Line Exchange operation. This will prevent chattering during the transition.

**I/O-30: Jog Frequency**

I/O▶ Jog freq  
30 10.00 Hz

Factory Default: 10.00 Hz

This parameter sets the jog frequency.

**I/O-31~42: Step Frequency 4, 5, 6, 7, 8, 9, 10, 11, 12, 13, 14, 15**

I/O▶ Step freq-4  
31 40.00 Hz

Factory Default: 40.00 Hz

I/O▶ Step freq-5  
32 50.00 Hz

Factory Default: 50.00 Hz

- 
- 
- 

**[Speed-L, Speed-M, Speed-H, Speed-X]**

By setting M1, M2, M3 terminals to ‘Speed-L’, ‘Speed-M’ and ‘Speed-H’ respectively, the drive can operate at seven preset frequencies set in DRV-21 ~ DRV-23 and I/O-31 ~ I/O-34. An additional terminal M(x) can be set to Speed X to allow eight additional preset frequencies (total of 15) using parameters I/O-35 ~ I/O-42.

The step frequencies are determined by the combination of M1, M2, M3 and Mx terminals as shown in the following table.

Parametr	Step Speed Frequency	Spd-X	Spd-H	Spd-M	Spd-L	JOG
DRV-00 (Note 1)	S. Freq-0 (Spd-0)	0	0	0	0	0
I/O-30 (Note 2)	Jog Freq	X	X	X	X	1
DRV-21	S. Freq-1 (Spd 1)	0	0	0	1	0
DRV-22	S. Freq-2 (Spd 2)	0	0	1	0	0
DRV-23	S. Freq-3 (Spd-3)	0	0	1	1	0
I/O-31	S. Freq-4 (Spd-4)	0	1	0	0	0
I/O-32	S. Freq-5 (Spd-5)	0	1	0	1	0
I/O-33	S. Freq-6 (Spd-6)	0	1	1	0	0
I/O-34	S. Freq-7 (Spd-7)	0	1	1	1	0
I/O-35	S. Freq-8 (Spd-8)	1	0	0	0	0
I/O-36	S. Freq-9 (Spd-9)	1	0	0	1	0
I/O-37	S. Freq-10 (Spd-10)	1	0	1	0	0
I/O-38	S. Freq-11 (Spd-11)	1	0	1	1	0
I/O-39	S. Freq-12 (Spd-12)	1	1	0	0	0
I/O-40	S. Freq-13 (Spd-13)	1	1	0	1	0
I/O-41	S. Freq-14 (Spd-14)	1	1	1	0	0
I/O-42	S. Freq-15 (Spd-15)	1	1	1	1	0

0: OFF, 1: ON, X: Ignored (Jog takes priority)  
 Speed-L: Lowest bit in Multi-Step speed input  
 Speed-M: Middle bit in Multi-Step speed input  
 Speed-H: High bit in Multi-Step speed input  
 Speed-X: Highest bit in Multi-Step speed input  
 Note 1: 'Speed 0' is based on the Freq. Ref. source set in DRV-04.  
 Note 2: If the 'Jog' terminal is ON, drive operates at Jog frequency regardless of other terminal inputs.

DRV-04 Data	DRV-00 Speed 0	Freq source
Keypad-1	Digital Freq Ref	Keypad
Keypad-2	Digital Freq Ref	Keypad
V1	Analog Freq Ref.	Terminal
V1S	Analog Freq Ref.	Terminal
I	Analog Freq Ref.	Terminal
V1+I	Analog Freq Ref.	Terminal
Pulse	Pulse Freq Ref.	Terminal
Int. 485	Communication	Terminal
Ext. PID	Ext. PID Freq Ref.	Keypad or Terminal

♣ Setting example (Seven Preset Speeds)

M1=Speed-L, M2=Speed-M, M3=Speed-H, M4=Jog  
 M5=BX, M7=FX, M8=RX  
 Step speeds are set in parameters DRV-21~23 and I/O-31~34.

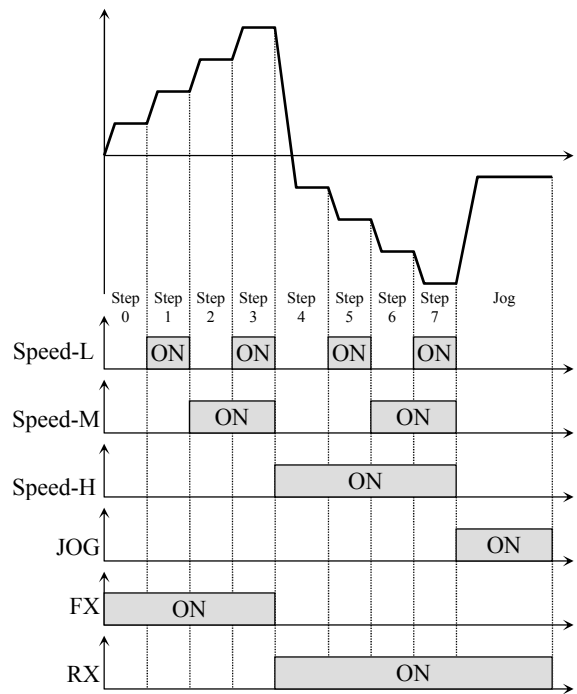

Multi-Step Frequency Operation

**I/O-50~63: 1<sup>st</sup>~7<sup>th</sup> Accel/Decel Time**

I/O▶ Acc time-1  
50      20.0 sec

Factory Default: 20.0 sec

I/O▶ Dec time-1  
51      20.0 sec

Factory Default: 20.0 sec

**Description of Digital I/O Selections**

**[XCEL-L, XCEL-M, XCEL-H]**

By setting M1, M2 and M3 terminals to ‘XCEL-L’, ‘XCEL-M’ and ‘XCEL-H’ respectively, up to eight different Accel and Decel times can be used. The Accel/Decel times are set in DRV-01, DRV-02 and I/O-50 ~ I/O-63.

The Accel/Decel time is determined by the combination of M1, M2 and M3 terminals as shown in the following table.

Parameter	Accel/Decel Time	XCEL-H (M3)	XCEL-M (M2)	XCEL-L (M1)
DRV-01	Accel Time-0	0	0	0
DRV-02	Decel Time-0			
I/O-50	Accel Time-1	0	0	1
I/O-51	Decel Time-1			
I/O-52	Accel Time-2	0	1	0
I/O-53	Decel Time-2			
I/O-54	Accel Time-3	0	1	1
I/O-55	Decel Time-3			
I/O-56	Accel Time-4	1	0	0
I/O-57	Decel Time-4			
I/O-58	Accel Time-5	1	0	1
I/O-59	Decel Time-5			
I/O-60	Accel Time-6	1	1	0
I/O-61	Decel Time-6			
I/O-62	Accel Time-7	1	1	1
I/O-63	Decel Time-7			

0: OFF, 1: ON

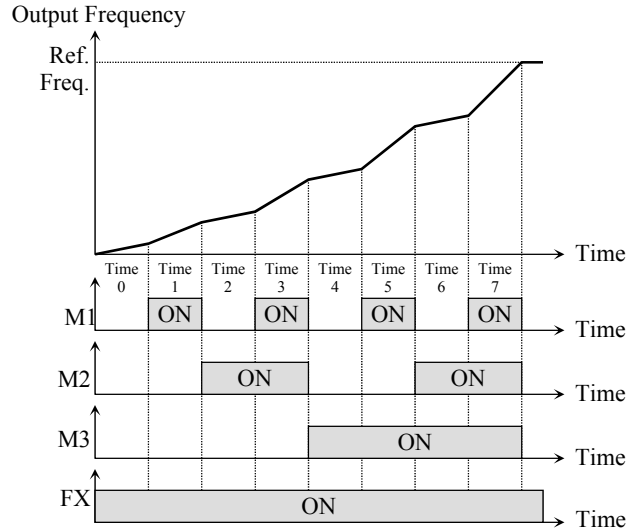

Multi-Accel/Decel Time Operation

**[Dc-brake]**

DC Injection Braking can be activated by configuring one of the multi-function input terminals (M1-M8) to ‘Dc-brake’. The preset DC-start value in FUN-22 is applied to the motor only when stopped. To activate the DC Injection Braking, close the contact of the assigned terminal while the drive is stopping.

**CAUTION** – DC is applied to the motor the entire time the input is closed.

While DC Brake is activated, the “FWD” and “REV” LED’s will blink.

**[2<sup>nd</sup> function]**

This function provides a second set of motor parameters when a different motor is connected to the drive. See APP 20~29 for details. Drive must be stopped to activate the second set of motor parameters.

**[EXCHANGE]**

Exchange is used to switch the motor from the drive output to line (commercial) power or from line to drive output. To bypass the motor to commercial line, set the 'Exchange' function in one of the multi-function input terminal in I/O-20~27 and set one multi-function output terminal (Ax-Cx) to 'INV line', and another to 'COMM line' with parameters I/O-76~79.

**Note:** Speed search function (AFN-22) is activated automatically during exchanging operation, enabling smooth exchange.

The following 3 settings should be made to activate the exchange function:

- 1) Set one of the Multi-function input terminals (I/O-20~27) to "Exchange."
- 2) Set one of the Multi-function Aux. Contact Output terminals to "INV line."
- 3) Set another Multi-function Aux. Contact Output terminal to "COMM line."

**Note:** I/O-29 [Filtering Time Constant for Multi-function Input Terminals] must be set to more than 100 [msec] to prevent chattering and resulting problems during the exchange.

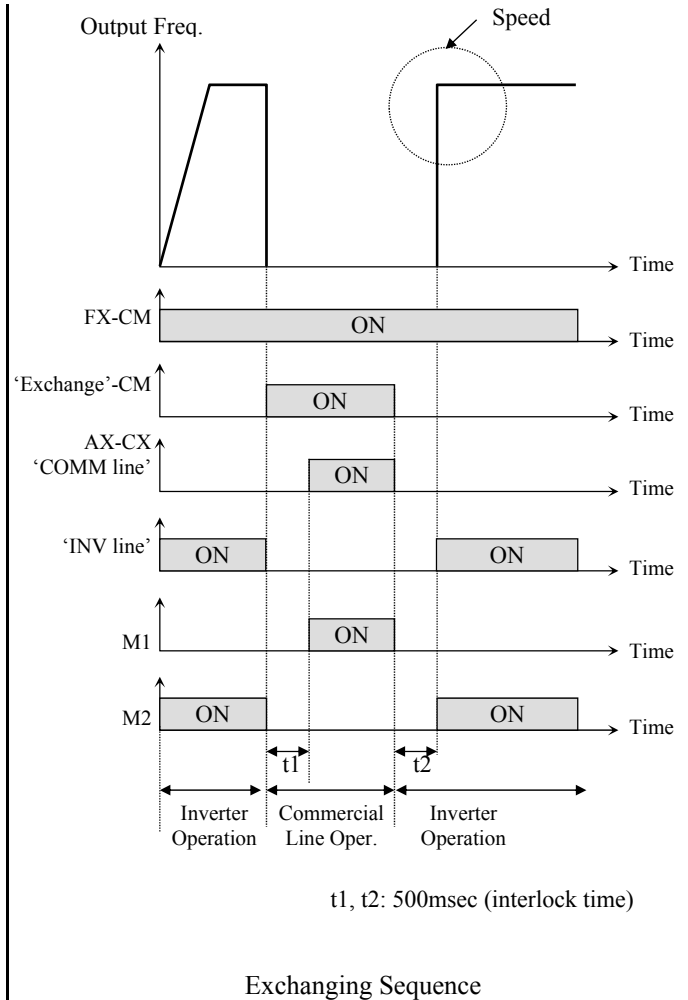

**[Up, Down]**

The speed of the drive can be controlled using two multi-function input terminals. Externally connected momentary switches can increase (Up) or decrease (Down) the speed of the drive. Setting limit is Maximum frequency. See also FUN-75 and FUN-76 for saving Up/Down speeds.

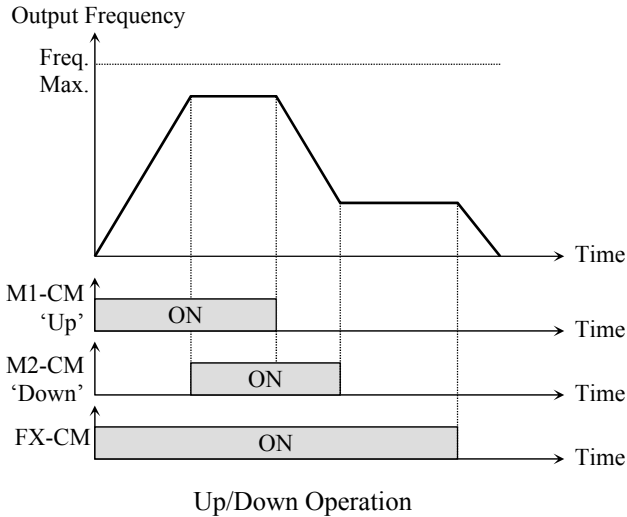

**[3-Wire]**

This function is used for 3-wire start/stop control. This function is used with a momentary push button (NO) to start and a momentary (NC) pushbutton for stop.

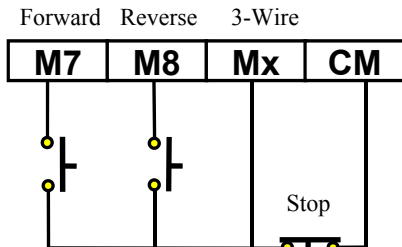

Wiring for 3-Wire Operation, Mx set to '3-Wire'

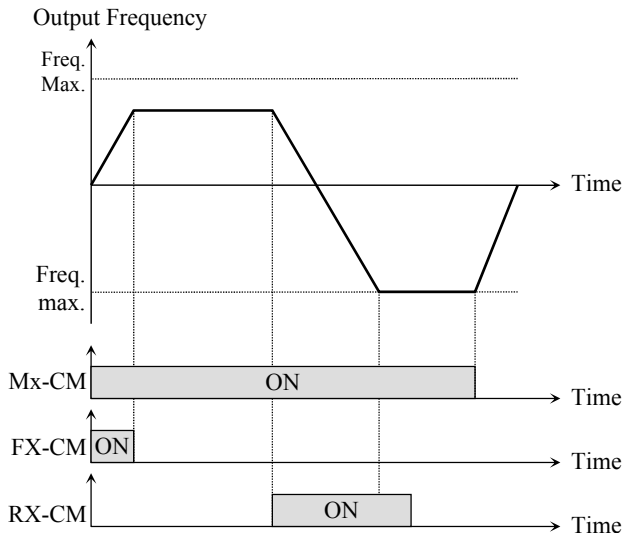

**[Ext Trip]**

This is a normally open contact input. When a terminal set to 'Ext Trip' is ON, the drive cuts off its output and displays an external fault. This can be used as an external latch trip or used when an external motor overload protection relay is used. The logic is programmable in I/O-95 [Normal Open/Normal Close select].

**[Pre-Heat]**

When a digital input, programmed to Pre-Heat is activated, the drive applies low levels of DC current to the motor. See FUN-10, 11 and 12.

**[iTerm Clear]**

This function is used for PID control. When this terminal is ON, the accumulated value of the integrator used by the I-Gain is set to '0'. Refer to the PID Control Block Diagram for more information.

**[Open-loop]**

This function is used to switch the control mode of the drive from PID mode to V/F mode (Open Loop). When a digital input, programmed to Open Loop is activated, DRV-03 [Drive Mode] and DRV-04 [Frequency Mode] control the drive.

**Note:** This function is only used when the drive is stopped.

**[LOC / REM]**

When the Local / Remote input is activated (ON), the Remote parameters, DRV-91 and DRV-92 control the drive command and drive frequency. When the input is deactivated (OFF), the Local parameters DRV-03 and DRV-04 control the drive command and drive frequency.



**[Analog hold]**

When there is an analog input signal for frequency reference and 'Analog hold' terminal is ON, drive fixes its output frequency regardless of the frequency reference. When the terminal is OFF, the actual frequency reference will be applied.

This function is useful when a system requires constant speed after acceleration or when the freq reference is not necessary to be changed.

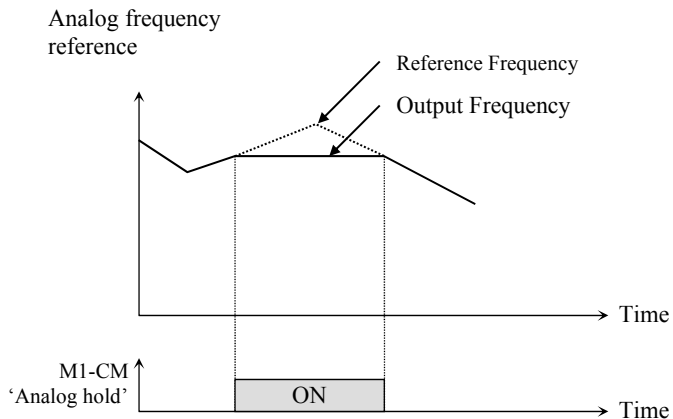

Analog Hold Operation

**[XCEL stop]**

Drive stops accelerating and decelerating when this terminal is ON.

**[P Gain 2]**

This function is used to change P-Gain during PID operation. When this terminal is ON, PID controller changes P-Gain to PID P2-Gain.

Refer to PID Control Block Diagram.

**[Interlock 1, 2, 3, 4]**

This function is used for MMC operation. When MMC is selected in APP-01 and interlock is set, M1, M2, M3 and M4 are automatically assigned for Interlock function. Therefore, these terminals cannot be used for setting other functions when interlock is active. Use M5, M6, M7, and M8 for other function setting. Refer to MMC operation.

**[Reset]**

This function is used as a fault reset terminal when ON. It requires a momentary contact closure for fault reset.

**[BX]**

This function is used to disable the drive output when ON. Can be used as an E-Stop function, requires a manual reset. The logic is programmable in I/O-95 [Normal Open/Normal Close select].

**[JOG]**

This function is used for Jog operation when ON. Jog speed is set with I/O-30.

**[FX/RX]**

These functions are used to issue Forward/Reverse run commands.

**[Ana Change]**

The drive changes its frequency reference source from V1 to I when ON.

**Ex) When DRV-04 is set to V1+I operation, V1 is the default setting and is changed to I operation when the terminal is turned ON.**

**[Ext.PID Run]**

External PID controller begins operation when the defined terminal is turned ON. This can be operated regardless of the drive reference command or used in conjunction with internal PID operation. Refer to External PID operation for details.

**[Up/Dn Clr]**

This function is used to reset (clear) the saved frequency when FUN-75, Up/Down Save Mode is set to "yes".

**I/O-70-73: S0, S1 terminal select**

I/O► S0 mode  
70 Frequency

Factory Default: Frequency

I/O► S0 adjust  
71 100 %

Factory Default: 100 %

I/O► S1 mode  
72 Voltage

Factory Default: Voltage

I/O► S1 adjust  
73 100 %

Factory Default: 100 %

Analog output signals from the S0, S1 terminals can be used to monitor/display the drive Output Frequency, Current, Voltage, DC link voltage, External PID and/or Power (Watts). The output voltage range is 0V to 10V. Parameters I/O-71, 73 are used to adjust the S0, S1 output gain value.

**[Frequency]**

The S0/S1 terminal provides an analog output corresponding to output frequency. The output value is determined by the following formula:

$$S0/S1 \text{ Output Voltage} = (\text{Output freq.} / \text{Max. freq.}) \times 10V \times (IO-71 \text{ or } 73) / 100.$$

**[Current]**

The S0/S1 terminal provides an analog output corresponding to current. The output value is determined by the following formula:

$$S0/S1 \text{ Output Voltage} = (\text{Output current} / \text{Rated current}) \times 10V \times (IO-71 \text{ or } 73) / 100.$$

**[Voltage]**

The S0/S1 terminal provides an analog output corresponding to the drives output voltage. The output value is determined by the following formula:

$$S0/S1 \text{ Output Voltage} = (\text{Output voltage} / \text{Max. output voltage}) \times 10V \times (IO-71 \text{ or } 73) / 100.$$

**[DC link vtg]**

The S0/S1 terminal provides an analog output corresponding to the dc link voltage. The output value is determined by the following formula:

$$S0/S1 \text{ Output Voltage} = (\text{DC link voltage} / \text{Max. DC link voltage}) \times 10V \times (IO-71 \text{ or } 73) / 100.$$

**Note:** Maximum DC Link Voltage for 230V class is 410V and for 460V class 820V.

**[Ext.PID Out]**

The S0/S1 terminal provides an analog output corresponding to the External PID output. The output value is determined by,

$$S0/S1 \text{ output voltage} = (\text{External PID output} / 10000) \times 10V \times S0, S1 \text{ output gain (I/O-71 or 73)} / 100.$$

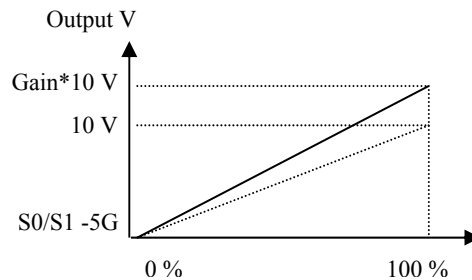

**[Watts]**

The S0/S1 terminal provides an analog output corresponding to output power. The output value is determined by the following formula:

$$S0/S1 \text{ Output Voltage} = (\text{Output Power} / 200\% \text{ Drive Rating}) \times 10V \times (IO-71 \text{ or } 73) / 100.$$

**Note:** Power calculation is effective power,  $\sqrt{3} \times V \times I$ .

**Note:** Output voltage of 10V is based on 200% drive rated power.

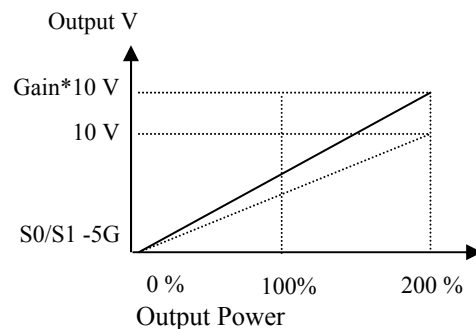

**I/O-74: FDT (Frequency Detection) Level  
I/O-75: FDT Bandwidth**

I/O▶ FDT freq  
74 30.00 Hz

Factory Default: 30.00 Hz

I/O▶ FDT band  
75 10.00 Hz

Factory Default: 10.00 Hz

These functions are used with I/O-76-79 [Multi-function Auxiliary Contact Output] when set to FDT-#. See [FDT-#] in I/O-76~79.

**I/O-76~79: Multi-function Auxiliary Contact Output mode 1, 2, 3, 4 define (Ax-Cx)**

I/O▶ Aux mode 1  
76 None

Factory Default: None

Terminals A1-C1, A2-C2, A3-C3, and A4-C4 are Form A relays that are programmable to the functions listed in the table below. The auxiliary contact will close when the defined condition has occurred. Each terminal can be programmed to a different function. In the following descriptions AX-CX is used to represent any one of the relay output terminals.

LCD Setting Range	Description
None	None
FDT-1	Reference frequency detection level – (At speed)
FDT-2	Specific frequency level detection
FDT-3	Frequency detection bandwidth
FDT-4	Frequency detection 1 with contact closure
FDT-5	Frequency detection 2 with contact closure
OL	Overload detection
IOL	Inverter overload detection
Stall	Stalling

LCD Setting Range	Description
OV	Over voltage detection
LV	Low voltage detection
OH	Inverter overheat detection
Lost Command	Lost command detection
Run	Inverter running detection
Stop	Inverter stop detection
Steady	Steady speed detection
INV line	Exchange signal outputs
COMM line	
Search	Speed search mode detection
Ready	Drive ready detection
MMC	Used for MMC operation
OH Warn	Over Heat Warning–See FUN-80, Over Heat Warning Level
FAN Signal	Closes when Fan On–See I/O-84
RMT Status	Closes when in Remote Control

**[FDT-1]**

When the output frequency reaches the reference frequency (target frequency), AX-CX terminal is CLOSED.

**Detecting Condition: Value (Ref. Freq-Output Freq) ≤ Freq Detection Bandwidth (I/O-75)/2**

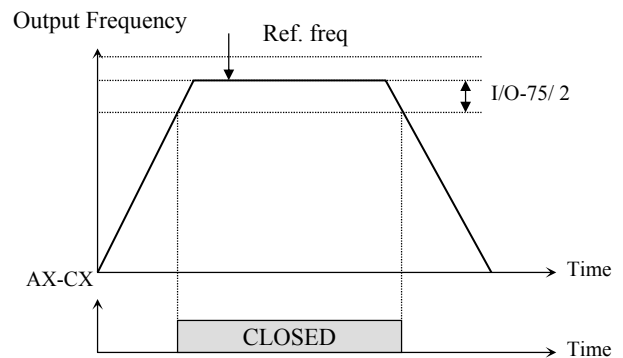

AX-CX configured as 'FDT-1'

\*AX: A1-A4, CX: C1-C4

**[FDT-2]**

AX-CX is CLOSED when the reference frequency is in I/O-75 [FDT Bandwidth] centered on I/O-74 [FDT Frequency], and the output frequency reaches I/O-75 centered on I/O-74.

**Detecting Condition:**  $FDT-1 \text{ condition} \ \& \ (Value \ (Output \ Freq - Freq \ Detection) \leq Freq \ Detection \ Bandwidth \ (I/O-75)/2)$

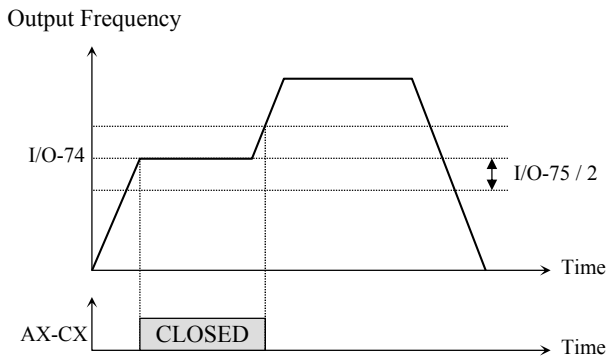

AX-CX configured as 'FDT-2'

**[FDT-3]**

AX-CX is CLOSED when the output frequency reaches the band centered on the FDT frequency. The output is OPENED when the output frequency goes outside the FDT bandwidth centered on the FDT frequency.

**Detecting Condition:**  $Value \ (Freq \ Detection \ (I/O-74) - Output \ Freq) \leq Freq \ Detection \ Bandwidth \ (I/O-75)/2$

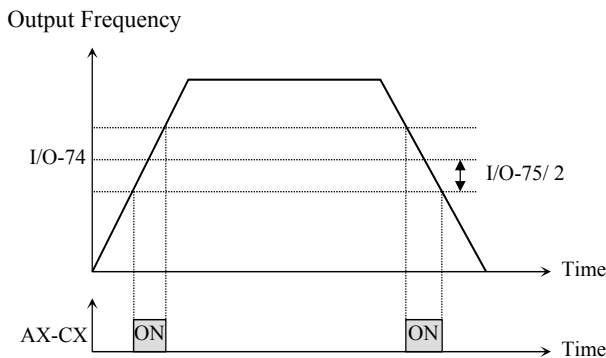

AX-CX configured as 'FDT-3'

**[FDT-4]**

AX-CX is CLOSED when the output frequency reaches the FDT frequency. The output is OPENED when the output frequency goes below the FDT bandwidth centered on the FDT frequency.

**Detecting Condition:**

**During Accel:**  $Output \ freq \geq Freq \ Detection$

**During Decel:**  $Output \ freq > (Freq \ Detection \ (I/O-74) - Freq \ Detection \ Bandwidth \ (I/O-75)/2)$

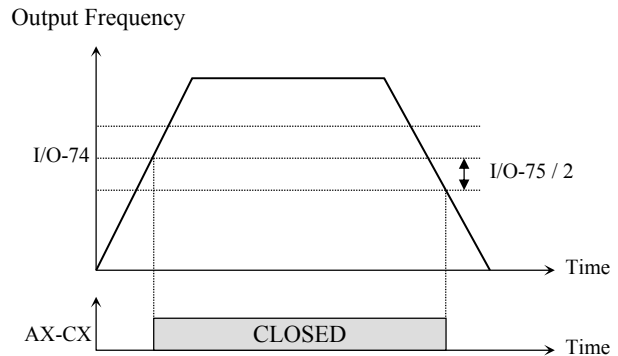

AX-CX configured as 'FDT-4'

**[FDT-5]**

This is the inverted output of [FDT-4].

**Detecting Condition:**

**During Accel:**  $Output \ freq \leq Freq \ Detection$

**During Decel:**  $Output \ freq < (Freq \ Detection \ (I/O-74) - Freq \ Detection \ Bandwidth \ (I/O-75)/2)$

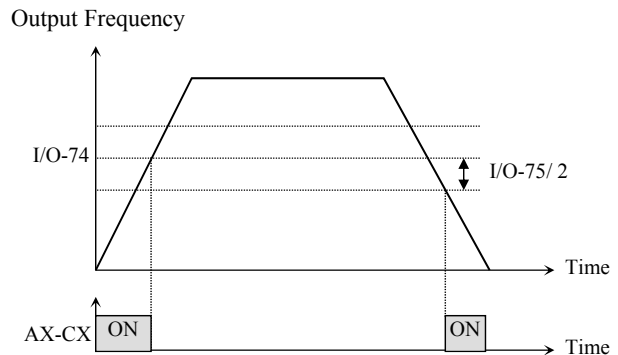

AX-CX configured as 'FDT-5'

**[OL]**

AX-CX is CLOSED when the output current has reached the FUN-64 [Overload Warning Level] for the FUN-65 [Overload Warning Time].

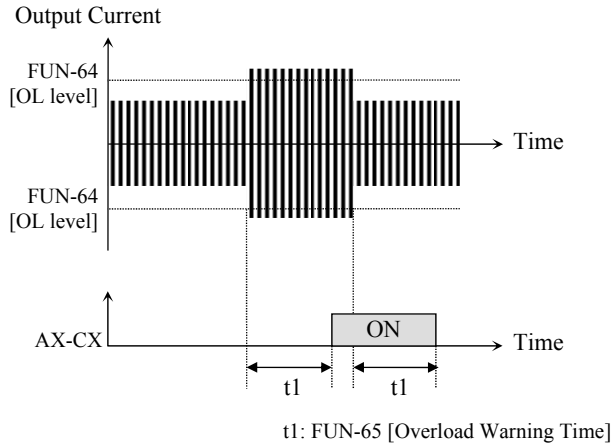

AX-CX configured as 'OL'

**[IOL]**

AX-CX is CLOSED when the output current is above the 110% of the drives standard duty rated current for 36 seconds. If this situation is continued for one minute, the drive will cut off its output and displays 'IOL' (Inverter overload) Trip. See the nameplate for the rated inverter current. The IOL function has an Inverse Time ( $I^2t$ ) characteristic and provides an alarm (closes relay) at 60% (36 secs) of the one minute time period.

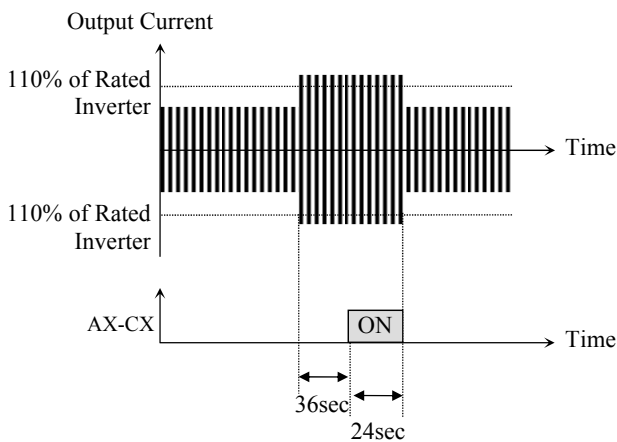

AX-CX configured as 'IOL'

**[Stall]**

AX-CX is CLOSED when the drive is in the stall prevention mode.

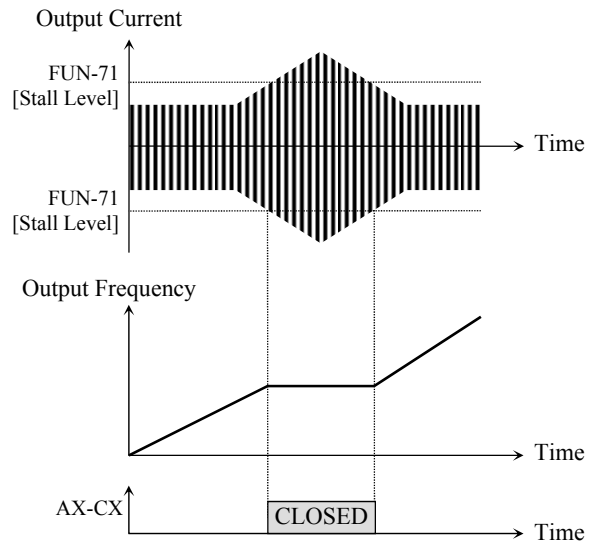

AX-CX configured as 'Stall'

**[OV]**

AX-CX is CLOSED when the DC link voltage is above the Over-voltage level.

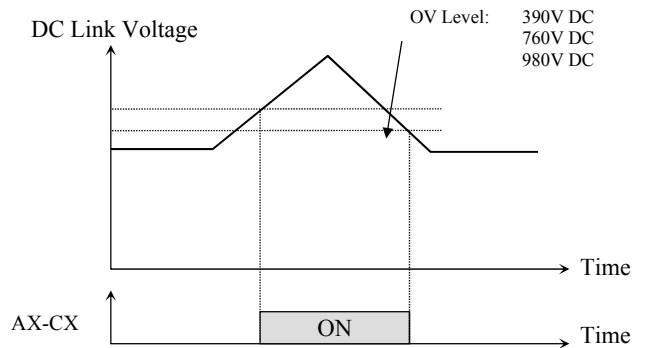

AX-CX configured as 'OV'

**[LV]**

AX-CX is CLOSED when the DC link voltage is below the Low-voltage level.

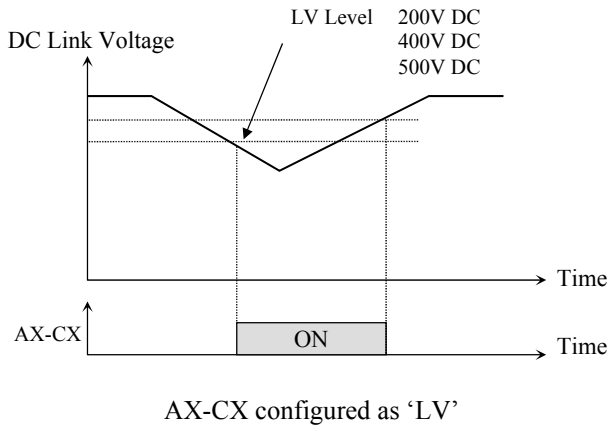

**[OH]**

AX-CX is CLOSED when the heat sink of the drive is above the reference level.

**[Lost Command]**

AX-CX is CLOSED when frequency reference is lost.

**[Run]**

AX-CX is CLOSED when the drive is running (above the start frequency, FUN-32). It does not close a 0 Hz.

**[Stop]**

AX-CX is CLOSED when the drive is stopped.

**[Steady]**

AX-CX is CLOSED when the drive is running at a constant speed.

**[INV line, COMM line]**

These functions are used in conjunction with the 'Exchange' function to transfer the output of the drive to commercial line power.

The following three conditions should be set:

- 1) Define one of the Multi-function input terminals to "Exchange".
- 2) Define one of the Multi-function output terminals to "INV line".
- 3) Define one of the Multi-function output terminals to "COMM line".

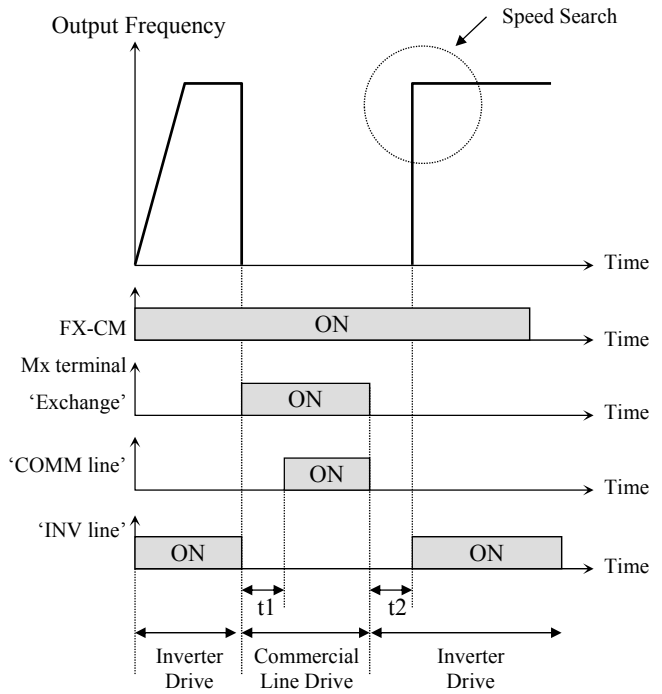

t1, t2: 500msec (interlock time)

AX-CX configured as 'COMM line' and 'INV line'. Mx terminal configured as 'Exchange'.

**[Search]**

AX-CX is CLOSED when the drive is speed searching.

**[Ready]**

AX-CX is CLOSED when the drive is ready to receive a start command and is ready to run.

**[MMC]**

Automatically set to 'MMC' when 'MMC' is selected in APP-01. See also APP-40 ~ APP-72.

**[OH Warn]**

AX-CX is closed when drive temperature reaches the percentage set in FUN-80, Over Heat Warning Level.

**[FAN Signal]**

AX-CX closes when fans are running. See I/O-84, Fan Control.

**[RMT Status]**

AX-CX closes when drive is in Remote Control.

**I/O-80: Fault Output Relay (3A, 3B, 3C)**

I/O▶ Relay mode  
80            010

Factory Default:    010

This parameter determines how the fault relay will operate during a fault condition and during low voltage conditions.

Bit	Setting	Display	Description
Bit 1 (LV)	0	000	Fault output relay does not operate at 'Low voltage' trip.
	1	001	Fault output relay operates at 'Low voltage' trip.
Bit 2 (Trip)	0	000	Fault output relay does not operate at any fault.
	1	010	Fault output relay operates at any fault except 'Low voltage' and 'BX' (inverter disable) fault.
Bit 3 (Retry)	0	000	Fault output relay does not operate regardless of the retry number.
	1	100	Fault output relay operates when the retry number set in AFN-26 decreases to 0 by faults. Disabled while Auto retry is ON.

When several faults occurred at the same time, Bit 1 has the first priority. (Active order: Bit 1->Bit 2->bit3)

**I/O-81: Terminal Output Status**

I/O▶ Out status  
81            00000000

Factory Default:    00000000

This parameter displays the condition of each of the outputs. This is useful in monitoring the status of the terminals.

----Not Used----

Output Terminals	3A-3C	Q3	Q2	Q1	AUX 4	AUX 3	AUX 2	AUX 1
	Bit 7	Bit 6	Bit 5	Bit 4	Bit 3	Bit 2	Bit 1	Bit 0
OFF status	0	0	0	0	0	0	0	0
ON status	1	1	1	1	1	1	1	1

**I/O-82, 83: Fault Relay On/Off Delay Time**

I/O▶ Relay On  
82            0.0 sec

Factory Default:    0.0 sec

I/O▶ Relay Off  
83            0.0 sec

Factory Default:    0.0 sec

The Fault relay ON time is delayed for the time set in I/O-82 and its OFF time is delayed by the amount of time in I/O-83.

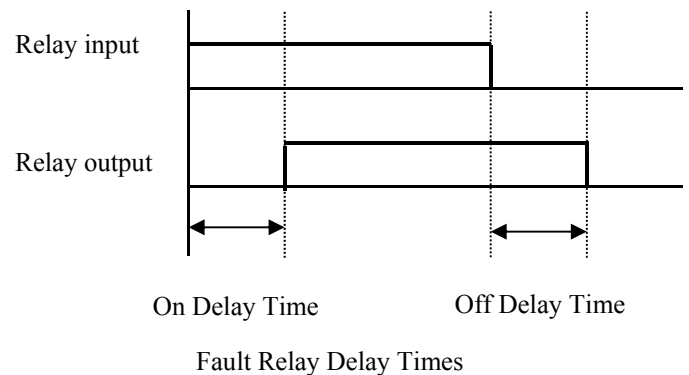

**I/O-84: Cooling Fan Control Selection**

I/O▶Fan Con. Sel  
84

Factory Default: PowerOn\_Fan

This parameter determines the operating condition of the drives cooling fans.

I/O-84 Setting Range	Description
PowerOn Fan	Fan is ON when power is ON.
Run Fan	Fan is ON when the drive runs (outputs frequency).
Temper Fan	Fan is ON when the drive temp exceeds the preset value in I/O-85.

**Note:** I/O-84, 85 are only programmable for drives 50HP and higher.

**I/O-85: Fan Temperature**

I/O▶Fan Temp  
85                      70

When I/O-84 is set to Temper Fan, this parameter sets the temperature at which the fans turn on.  
Range 0 – 70 degrees Celsius

**Note:** I/O-84, 85 are only programmable for drives 50HP and higher.

**I/O-86: User Unit selection (PI Mode only)  
I/O-87: Units Maximum Value**

I/O▶ Unit Sel  
86                      Percent

Factory Default: Percent (PSI in PI Mode)

When PID operation is selected in APP-02, APP-80, or APP-62, the drive displays units in PSI, rather than speed (Hz.). The user can chose units to display listed in the table below.

I/O-86 Setting Range	Description
Percent	Flow rate, pressure and temperature are displayed in [%].
Bar	Pressure is displayed in [Bar].
mBar	Pressure is displayed in [mBar].
kPa	Pressure is displayed in [kPa].
Pa	Pressure is displayed in [Pa].
Psi	Pressure is displayed in [Psi].

I/O Unit Max Val  
87                      100.0%

Factory Default: 100.0 % (PSI in PI Mode)

**Scaling: I/O-87,** Unit Maximum Value is used to set the maximum value of the units selected in I/O-86. If PSI (I/O-86) is selected and sensor maximum pressure is 300 PSI, enter 300 PSI. When “I” is selected as the feedback (APP-06 default), scaling of the “I” is done with parameters I/O-87, Max. Pressure along with parameter APP-31 “meter I max”. These two parameters set the maximum pressure at the maximum feedback signal (default is 20mA). See table below.

Scaling of feedback signal “I”.

Param	Factory setting	Description
<b>I/O-86</b>	<b>PSI</b>	<b>Units select</b>
<b>I/O-87</b>	<b>100.0 PSI</b>	<b>Max. Pressure</b>
<b>APP-06</b>	<b>I</b>	<b>Feedback select</b>
<b>APP-31</b>	<b>20 mA</b>	<b>Max. Feedback signal at Max. Pressure</b>



Likewise if “V1” is chosen as feedback (APP-06), parameter APP-32, “meter V max” is the maximum value of the feedback voltage (default is 10V) corresponding to the maximum PSI value, I/O-87.

Scaling of feedback signal “V1”.

Param	User setting	Description
I/O-86	PSI	Units select
I/O-87	100.0 PSI	Max. Pressure
APP-06	V1	Feedback select
APP-32	10 V	Max. Feedback signal at Max. Pressure

**Note:** When APP-02, APP-80 or APP-62 are set to “No”, units in I/O-86 are not used, all parameters default to Speed [Hz].

I/O-90: Inverter Number  
 I/O-91: Baud Rate  
 I/O-92: COM Lost Cmd  
 I/O-93: COM Time Out  
 I/O-94: Delay Time

I/O► Inv No.  
 90 1

Factory Default: 1

I/O-90 [Inverter Number] sets the drives ID number for RS-485/Modbus communication.

I/O► Baud rate  
 91 9600 bps

Factory Default: 9600 bps

I/O-91 [Baud rate] sets the communication speed. Terminals C+ and C- are used for RS-485 communication.

I/O► COM Lost Cmd  
 92 None

Factory Default: None

I/O-92 [Com Lost command] determines the method of operation if the communication signal is lost. If lost, the drive will display LOR on the LCD display. The possible functions for I/O 92 are shown in the following table:

Setting Range	Description
None	Continuous operation after loss of communication signal.
FreeRun	Drive cuts off its output after determining loss of communication signal.
Stop	Drive stops by its Decel pattern and Decel time after determining loss of communication signal.

I/O► COM Time Out  
 93 1.0 sec

Factory Default: 1.0 sec

I/O-93 [Communication time out] sets the delay time before the drive faults after the communication signal is lost. When lost, the drive will display LOR on the LCD display.

I/O► Delay Time  
 94 5

Factory Default: 5 ms

I/O-94 setting is for communications using RS232-RS485 converters. It should be set properly according to RS232-RS485 converter specification.

**I/O-95: Normal Open/ Normal Closed select**

I/O► In No/NC Set  
95 00000000

Factory Default: 00000000

The digital inputs, M1, M2, M3, M4, M5, M6, M7, and M8 can be programmed as a NO or a NC contact. If the terminal is programmed as NO, the input will have to be closed to activate the programmed function. If the terminal is programmed as NC, the input will have to be opened to activate the function.

Input T/M	M8	M7	M6	M5	M4	M3	M2	M1
	Bit 7	Bit 6	Bit 5	Bit 4	Bit 3	Bit 2	Bit 1	Bit 0
0: NO	0/1	0/1	0/1	0/1	0/1	0/1	0/1	0/1
1: NC	0/1	0/1	0/1	0/1	0/1	0/1	0/1	0/1

**I/O-96: Input Checking Time**

I/O► In CheckTime  
96 1 ms

Factory Default: 1 ms

This sets the amount of time the drive will wait to confirm a valid input signal on one of the digital inputs.

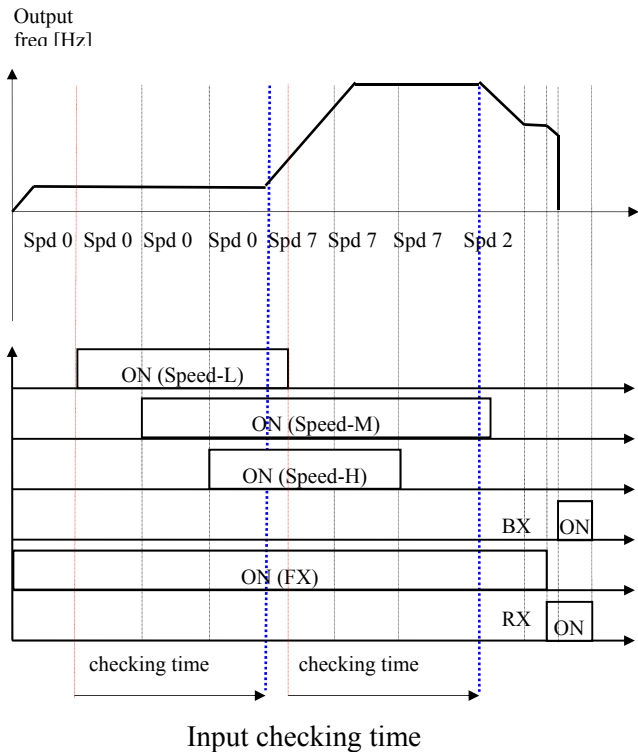

**I/O-97: Overheat Trip Selection**

I/O► OH Trip Sel  
97 010

Factory Default: 010

**I/O-98: Motor Trip Temperature**

I/O► MotTripTemp  
98 110

Factory Default: 110 [°C]

Setting Range 0 – 255 °C

The drive can monitor motor temperature by connecting a motor thermistor (PTC/NTC) to terminals NT-5G (40 HP and below) or terminals ET-CM (50 HP and above). See Thermistor Specifications on the following page. Motor trip temperature is set with I/O-98. Motor temperature can be viewed at parameter FUN-56, Motor Temperature.

Param	Bit set			Function
	2	1	0	
I/O-97			1	Motor overheat trip activation 0=Off, 1=On
		1		-Reserved-
	1			External temperature sensor selection 0=NTC, 1=PTC

Note: Bit 1 is not used.

Examples:

Setting I/O-97 to 001 activates the motor overheat protection using an NTC sensor.

Setting I/O-97 to 101 activates the motor overheat protection using a PTC sensor.

In both cases, set motor trip temperature in I/O-98. The fault displayed when using this protection is “EXT. OHT”, External Over Heat fault.

**NOTE: Inverter Overheat protection is activated regardless of motor temp setting condition.**

**NOTE: Overheat protection can be monitored by setting one of the Aux Relays (I/O-76 ~ 79) to OH.**

**Specification of External PTC/NTC Thermistor**

Sensor	Resistance based on 25 C	Resistance by temperature	Measurable Temp range
PTC	1KΩ] (±5%)	$R(T)=[1+A*(\text{Measured temp}-25)+B*(\text{Measured temp}-25)^2][K]$ A=7.635X10 <sup>-3</sup> , B=1.371 X10 <sup>-5</sup>	0~125[C]
NTC	2.545KΩ] (±5%)	See the table below for NTC resistance by temperature.	0~150[C]

**Note :** Measurable temp range varies by thermal sensors. Select the sensor after checking the measurable temp range specification.

**NTC resistance according to temperature**

Temp [C]	R [KΩ]	Temp [C]	R [KΩ]	Temp [C]	R [KΩ]	Temp [C]	R [KΩ]	Temp [C]	R [KΩ]	Temp [C]	R [KΩ]	Temp [C]	R [KΩ]
80	0.3562	90	0.2649	100	0.2002	110	0.1536	120	0.1195	130	0.0942	140	0.0752
81	0.3455	91	0.2574	101	0.1949	111	0.1497	121	0.1167	131	0.0921	141	0.0736
82	0.3353	92	0.2502	102	0.1897	112	0.1459	122	0.1139	132	0.0900	142	0.0720
83	0.3254	93	0.2432	103	0.1847	113	0.1423	123	0.1112	133	0.0880	143	0.0705
84	0.3158	94	0.2364	104	0.1798	114	0.1387	124	0.1085	134	0.0860	144	0.0690
85	0.3066	95	0.2299	105	0.1751	115	0.1353	125	0.1060	135	0.0841	145	0.0675
86	0.2976	96	0.2236	106	0.1705	116	0.1319	126	0.1035	136	0.0822	146	0.0661
87	0.2890	97	0.2174	107	0.1661	117	0.1287	127	0.1011	137	0.0804	147	0.0647
88	0.2807	98	0.2115	108	0.1618	118	0.1255	128	0.0987	138	0.0786	148	0.0633
89	0.2727	99	0.2058	109	0.1577	119	0.1225	129	0.0965	139	0.0769	149	0.0620
												150	0.0608

**Note:** Use the external NTC having the specification shown above and adjust I/O-98 when there is a temperature difference between the drive and external sensor.

**NOTES:**

## 6.5 Application group [APP]

### APP-00: Jump to Desired Parameter

APP▶ Jump code  
00 1

Factory Default: 1

Jumping directly to any parameter can be accomplished by programming the desired parameter number.

### APP-01: Application Mode Selection

APP▶ App. mode  
01 None

Factory Default: None

This parameter sets the desired application mode.

LCD Setting Range	Description
None	Application mode is not selected.
MMC	MMC (Multi-Motor Control) mode is selected in application group. Related parameters (APP-40~72) are displayed. Relay parameters I/O-76~79 are automatically set to “MMC” for controlling multiple motors via across the line starting. If less than 4 auxiliary motors are connected, the remaining relays can be used for other functions.

**Caution:** When APP-01 is set to “MMC”, then set back to “None”, parameters I/O-76 ~ 79 need to be programmed to their desired function. They do not automatically return to their previous setting.

### APP-02: PID Operation Selection

APP▶ Proc PI mode  
02 No

Factory Default: No

This function can be used for process control. It can control flow, pressure, temperature or other process variables. To use this function, set APP-02 [proc PI mode] to “Yes”. PID control detects the amount of feedback from a sensor and compares it with the target value. If the values differ, this function produces an output to eliminate the deviation. In other words, this control matches the target value with the feedback amount.

For HVAC or Pump applications, the PID control can be used to adjust the actual output by comparing a feedback signal with a ‘Set-point’ given to the drive. This ‘Set-point’ can be in the form of Speed, Temperature, Pressure, Flow, Level, etc. The ‘Set-point’ can be entered via the keypad or via the analog input terminals. See APP-04 and APP-05. The feedback signal is provided externally to the drive via the analog input terminals. The drive compares the signals to calculate ‘total-error’ which is reflected in the drive's output.

**Note:** PID control can be bypassed to manual operation temporarily by defining one of the multifunction input terminals (M1~M8) to “Open-loop”. The drive will change to manual operation from PID control when this terminal is ON, and change back to PID control when this terminal is OFF.

**[P Control]** The P gain is the proportional part of the feedback loop. The higher the P value, the faster the drive will respond to process error. When P control is used alone, the system could become unstable. The I Control parameter should also be used.

**[I Control]** The I Control is the integral part of the feedback loop. This is used to compensate the steady state error by accumulating them. Using this control alone makes the system unstable. The P control should also be used.

**[PI control]** This control is stable in many systems. If “D control” is added, it becomes the 3<sup>rd</sup> order system. In some systems this may lead to system instability.

**[D Control]** The D control is the derivative part of the feedback loop. Its primary purpose is to remove “hunting” in the control. The D control typically is more complicated to implement, but will result in a more stable system. This control does not affect the steady state error directly, but increases the system gain because it has an attenuation effect on the system. As a result, the differential control component has an effect on decreasing the steady state error. Since the D control operates on the error signal, it cannot be used alone. Always use it with the P control or PI control.

**Parameter setting example for PID operation**

- ① Set APP-02 [PID operation selection] to “Yes.”
  
- ② Select the set-point source if different from keypad in APP-04~05 (Aux. Ref. Signal). Refer to the following PID block diagram.  
**Note:** When APP-04 is set to “No,” DRV-04 [Freq Mode] becomes PID set point source. The default setting for DRV-04 is Keypad-1. Program the set point via the keypad at the main screen (DRV-00). If APP-04 is set to “Yes”, the selection set in APP-05 becomes PID set point source.
  
- ③ Set APP-06 [PID feedback selection] to I, V1 or Pulse.
  
- ④ Select the desired units (default PSI) of the process signals in I/O-86 [User unit selection]. This changes the units of the parameters related to the process (Target, Set Point, Feedback). They can be set to Percent, Bar, mBar, kPa, Pa, or PSI.
- ⑤ Select the maximum value of the sensor (units) in I/O-87.

⑥ Select the maximum value of the feedback signal in APP-31 (default 20 mA for “I”), APP-32 (default 10V for “V1”) or APP-33 (default 100kHz for “P”).

⑦ Select frequency limits of the drive output (if required) with APP-10 and APP-11.

⑧ Select the polarity of the PID output with APP-15.  
 “No” is direct (normal)  
 Feedback increase, Speed decrease.  
 “Yes” is indirect (inverse)  
 Feedback increase, Speed increase.

⑨ Adjust P and I gains (APP-07 and APP-08) as necessary to obtain stable operation.

⑩ Viewable parameters are:

DRV-15	TAR 0.00 Hz OUT 0.00 Hz
DRV-16	REF 0.00 PSI (Units per I/O-86) FBK 0.00 PSI
DRV-18	R 0.0 Hz T 0.0 Hz F 0.0 Hz O 0.0 Hz

**Open Loop function:** To disable PID control, program one of the multi-function input terminals (I/O-20 through 27) to the “Open loop” function. In Open Loop Mode, parameter DRV-04 will be the source of the drives speed reference. To change to another source for speed reference in Open Loop, use the Loc/Rem function. See I/O-20 ~ I/O-27, Loc/Rem function.

**Note:** The accumulated integrator value used by I-Gain can be set to ‘0’ by setting a multi-function input terminal (M1 ~ M8) to ‘iTerm Clear’ in I/O-20 ~ I/O-27.

**Note:** The P-Gain 2 can be selected for PID controller by setting a multi-function input (I/O-20 ~ I/O-27) to ‘P Gain 2’.

# PID Block Diagram

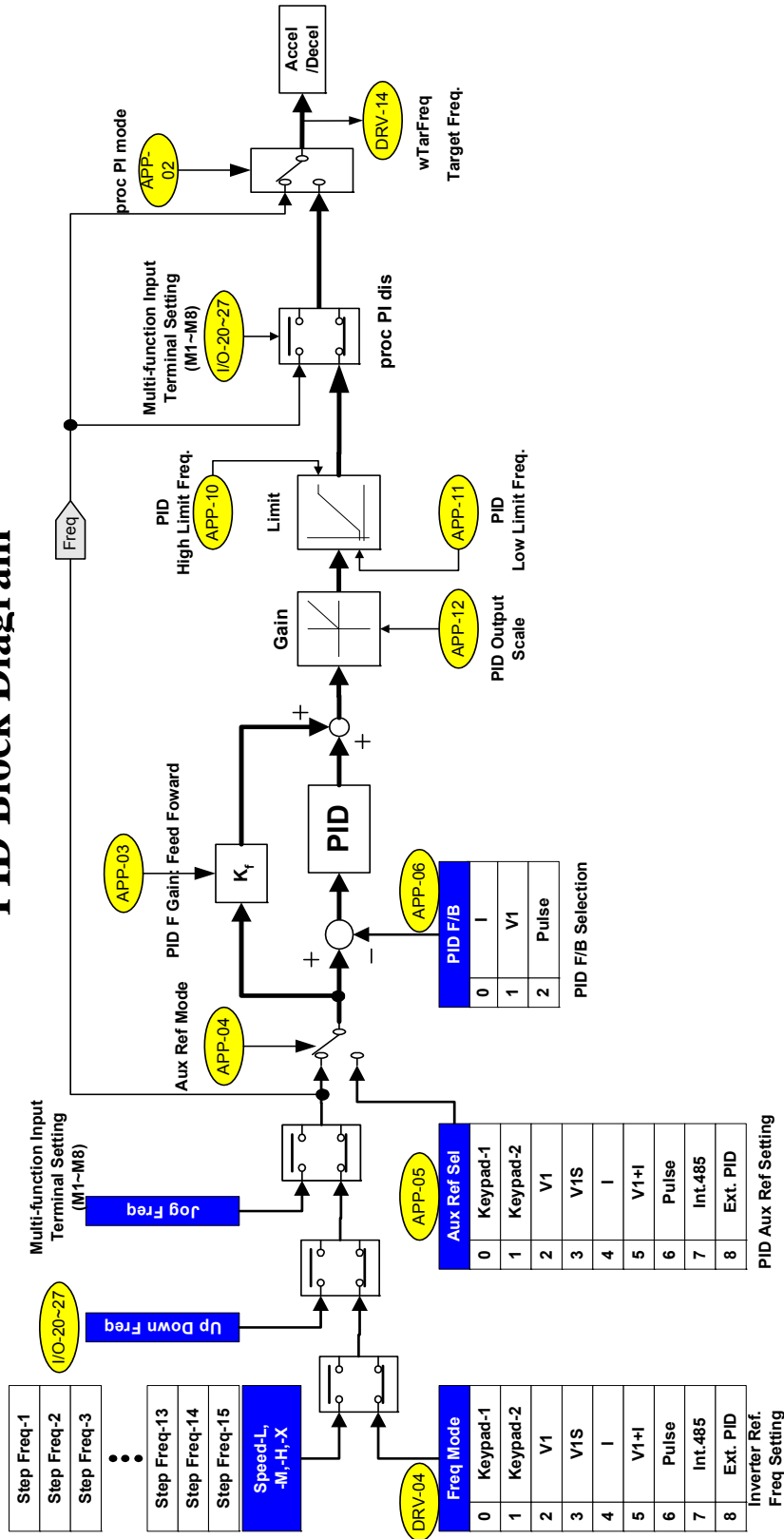

In general, the PID output becomes the drive's "Target Freq". In this case, PID is controlling the whole system and the PID output becomes the target freq of the system and the drive is operating according to Accel/Decel Time. PID control sampling time is 10msec.

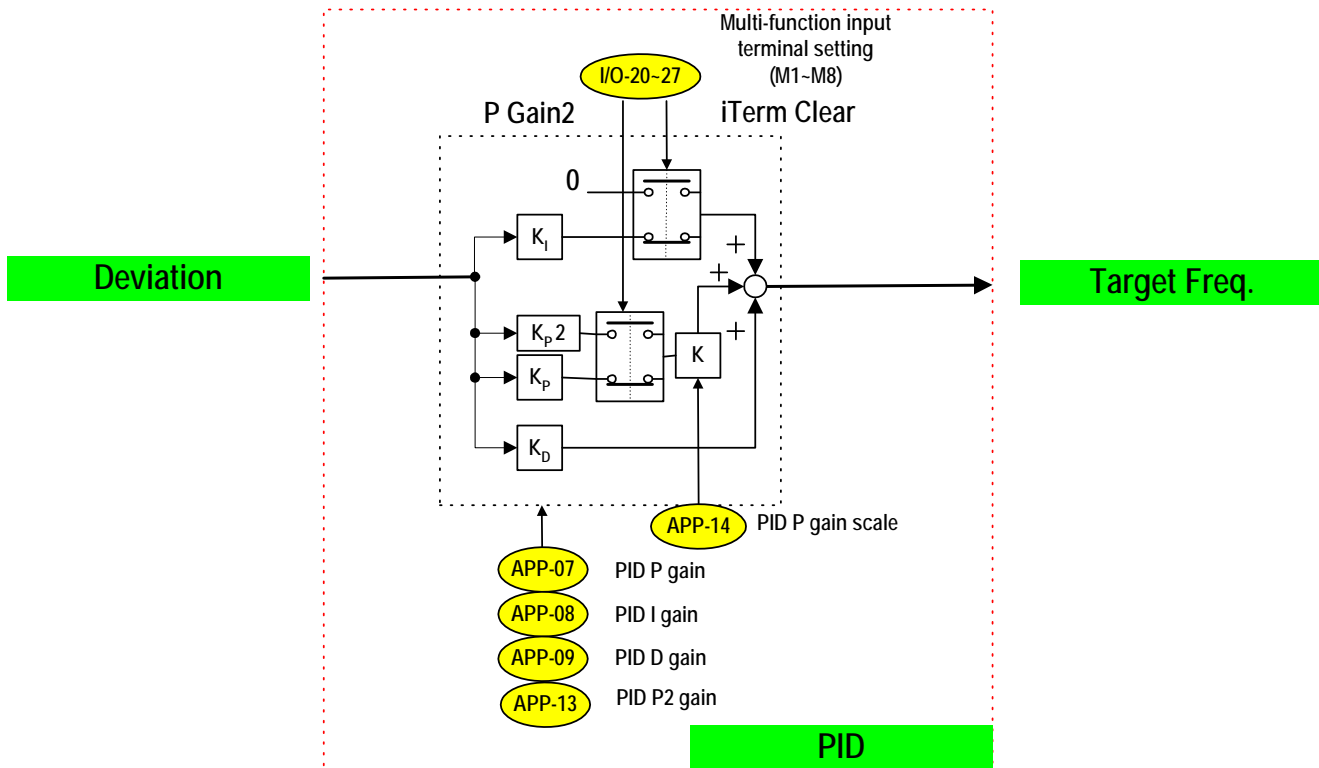



**PID Wiring Example**

**Keypad as Set point**  
**Feed Back as I (4-20mA)**

DRV-04 Keypad  
 DRV-00 Set Point (program)  
 APP-06 I (4-20mA) Feedback  
 I/O-26 FX (M7 Fwd Run/Stop)  
 I/O-27 RX (M8 as Rev Run/Stop)  
 I/O-20 Open Loop (M1 to disable PI Control)

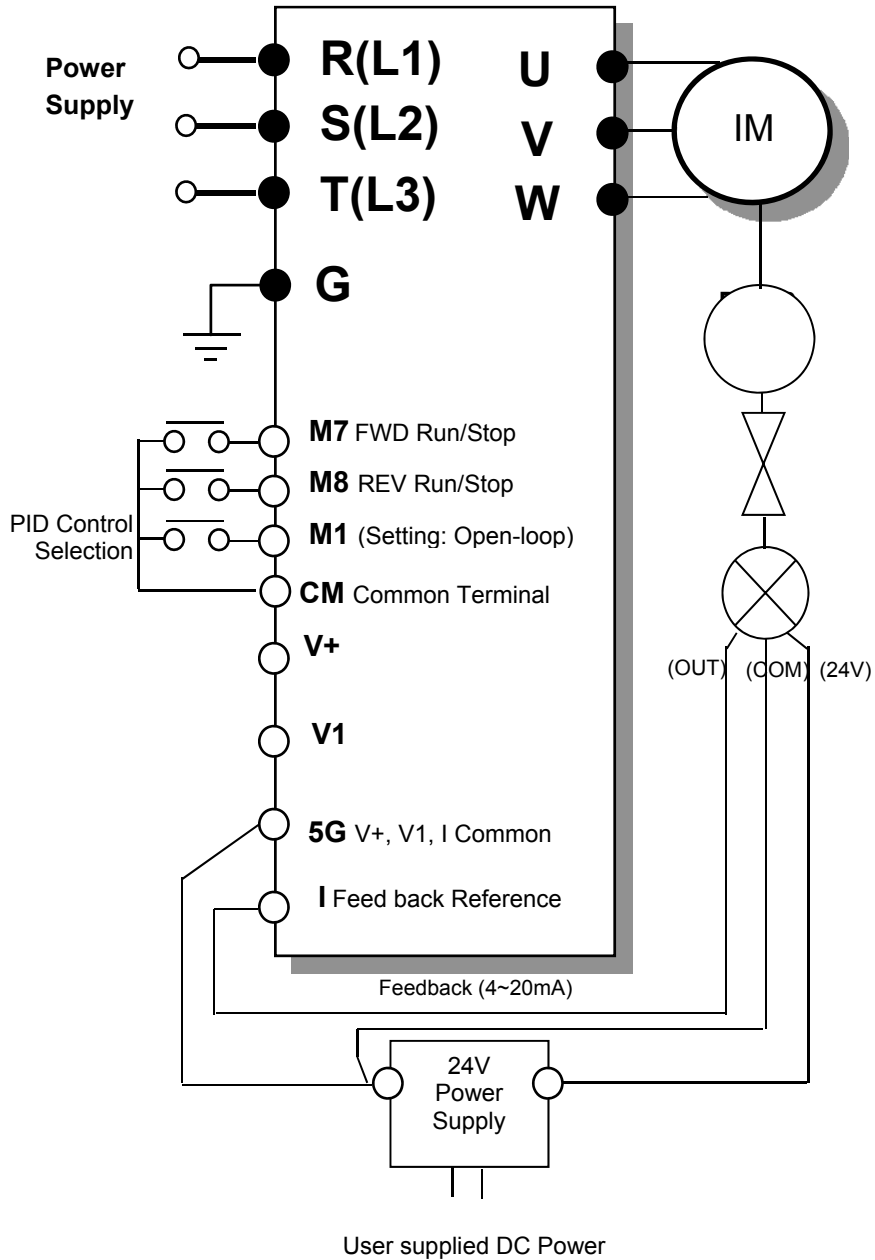

APP-03: PID F Gain  
 APP-04: PID Aux. Reference Mode Selection  
 APP-05: PID Aux. Reference Selection

APP► PID F-Gain  
 03            0.0 %

Factory Default: 0.0%

This parameter sets F Gain for use in Feed Forward control. When it is set to 100%, the responsiveness (%) of output F gain from the controller reference value is 100%. Use when fast response is needed.

**Caution: Control System output may become unstable if this value is set too high. This parameter is not typically required for most PID systems.**

APP► Aux Ref Mode  
 04            No

Factory Default: No

This parameter selects PID Aux Ref. Input Enable/Disable. See PID Block Diagram for details. When this parameter is set to “No”, the drive uses the source set in DRV-04 as its set point (reference). If this value is set to “Yes”, the drive will use the source set in APP-05 as its set point (reference).

APP► Aux Ref Sel  
 05            V1

Factory Default: V1

This parameter sets the source of Aux reference (set point) signal.

APP-06: PID Feedback Signal Selection  
 APP-07: P Gain for PID Control  
 APP-08: I Time for PID Control  
 APP-09: D Time for PID Control

APP► PID F/B  
 06            I

Factory Default: I

This parameter determines which input will be the feedback signal for the PID loop. The default is set to the "I" terminal, but can be changed to the “V1”, “VIS”, or Pulse input terminals.

APP► PID P-gain  
 07            1.0 %

Factory Default: 1.0 %

This parameter sets the proportional gain of the PID controller. When P-Gain is set at 100% and I-Time at 0.0 second, the PID controller output is 100% for 100% error value. When P-Gain is set to 50% and I-Time to 0.0 sec, the PID controller output becomes 50% for 100% error value.

APP► PID I-time  
 08            10.0 sec

Factory Default: 10.0 sec

This parameter sets the integral gain of the PID controller. This is the time the PID controller takes to output 100% for 100% error value. For example, when it is set to 30 sec, it takes 30 sec. for the PID controller to output 100% for 100% error value. 100% error means that the feedback value is 0 as compared to the preset reference value (setpoint).

APP► PID D-time  
 09            0.0 ms

Factory Default: 0.0 ms

This parameter set the differential gain of the PID controller.

**APP-10: High Limit Frequency for PID Control**  
**APP-11: Low Limit Frequency for PID Control**

APP► PID limit-H  
 10          60.00 Hz

Factory Default: 60.00 Hz

This is the upper limit frequency at which the output frequency is limited during PID control.

APP► PID limit-L  
 11          0.50 Hz

Factory Default: 0.50 Hz

This is the lower limit frequency at which the output frequency is limited during PID control.

**APP-12: PID Output Scale**  
**APP-13: PID P2 Gain**  
**APP-14: P Gain Scale**

APP►PID Out Scale  
 12          100.0 %

Factory Default: 100.0 %

This parameter sets the scale of PID controller output.

APP► PID P2-gain  
 13          100.0 %

Factory Default: 100.0 %

This parameter sets the second P-Gain for PID control.

APP►P-gain Scale  
 14          100.0 %

Factory Default: 100.0 %

This parameter sets the conversion scale of P-Gain and P2-Gain.

**APP-15: PID Output Inversion**

APP► PID Out Inv.  
 15                  No

Factory Default: No

Parameter APP-15 [Output inversion] sets the PID controller's output polarity. The output can be direct (No) or inverted (Yes).

**Note:** Most applications require (No), this means as the pressure (or process variable) rises in the system, the speed will fall. If this parameters is set to (Yes), the speed will increase if the pressure (or process variable) increases.

**APP-17: PID Feedback U Adjustment**

APP► PID U Fbk  
 17                  No

Factory Default: NO

This feature can be useful for fan and pumps application. It converts the linear pattern of a feedback sensor to the squared pattern without any additional settings.

**APP-20 ~ APP-29: 2<sup>nd</sup> Functions**

APP▶2<sup>nd</sup> Acc time  
20      5.0 sec

Factory Default: 5.0 sec

APP▶2<sup>nd</sup> Dec time  
21      10.0 sec

Factory Default: 10.0 sec

The purpose of these parameters is to provide the user with a second set of motor parameters. This can be useful on test stands with different motors or where a user will be testing different types of applications using two different motors. These parameters are displayed only when one of the multifunction inputs in parameters I/O-20 to I/O-27 is set to '2nd func'. Contact closure to the input activates the 2<sup>nd</sup> Function parameters. Drive must be stopped to activate the second set of parameters.

Description	1 <sup>st</sup> Functions	2 <sup>nd</sup> Functions
Acceleration time	DRV-01 [Acc. time]	APP-20 [2nd Acc time]
Deceleration time	DRV-02 [Dec. time]	APP-21 [2nd Dec time]
Base Frequency	FUN-31 [Base freq]	APP-22 [2nd BaseFreq]
Volts/Hz mode	FUN-40 [V/F Pattern]	APP-23 [2nd V/F]
Forward torque boost	AFN-68 [Fwd Boost]	APP-24 [2nd F-boost]
Reverse torque boost	AFN-69 [Rev Boost]	APP-25 [2nd R-boost]
Stall prevention level	FUN-60 [Stall Level]	APP-26 [2nd Stall]
ETH level for 1 minute	DRV-07 [ETH 1min]	APP-27 [2nd ETH 1min]
ETH level for continuous	DRV-08 [ETH cont]	APP-28 [2nd ETH cont]
Motor rated current	DRV-05 [Rated-Curr]	APP-29 [2nd R-Curr]

**APP-31: Meter I Max Value  
APP-32: Meter V1 Max Value  
APP-33: Meter P Max Value**

APP▶ meter I max  
31      20.00 mA

APP▶ meter V max  
32      10.00 V

APP▶ meter P max  
33      100.0 kHz

When PI Control is selected in APP-02, these parameters are used for scaling the maximum feedback signal level at the maximum sensor pressure set in I/O-87.

## APP-40~APP-72: MMC Operation Control

**Multiple Motor Control**

[MMC]: The 'PID' control should be selected in APP-02 to use this function.

◆ One drive can control multiple motors. This function is often used when controlling the flow rate or pressure of fans or pumps. The built-in PI controller directly controls a drive connected motor after receiving process control feedback value and keeps the control value constant by adjusting the speed of the drive connected motor and connecting and removing auxiliary motors to and from the commercial line when needed.

◆ In the case that the flow rate or flow pressure is beyond or below the reference and the drive connected motor cannot achieve the desired set point by itself, auxiliary motors are automatically turned on or off. A maximum of four (Aux.1-4 output) auxiliary motors can be controlled. Each motor's Starting and Stopping Frequency can be set to automatically run four auxiliary motors.

◆ **Auto Change** can be selected (APP-66) to automatically switch the order of the running motors for balancing motor run-time. Set to AUX\_EXCH mode for automatic changing of auxiliary motors only and set to MAIN\_EXCH mode for automatic changing of all motors including main motor. For MAIN\_EXCH mode APP-67/68 should be set and external sequence (APP-66) should be configured.

◆ A malfunctioning motor can be skipped from running by programming the multi-function input terminals (M1, M2, M3, and M4) as Interlock1 → Interlock4. If a programmed multi-function terminal (M1, M2, M3 and M4) is opened (tripped), the drive stops all running motors and restarts operation with only the normal motors and leaves the malfunctioning motor off. (Refer to APP-69)

◆ Sleep function is initiated when demand is low. The drive stops the motor when the motor runs below the Sleep Frequency after the Sleep Delay Time has expired. While in the sleep state, the drive continues monitoring the input (feedback) and initiates a Wake-Up function when the feedback has decreased below the Wake-Up level (APP-65).

**Note: Up to 4 auxiliary motors can be connected to the AUX terminals on the control board terminal strip.**

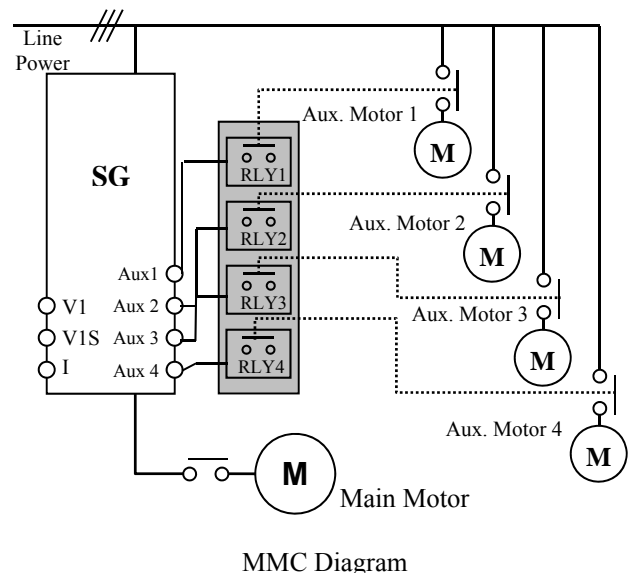

See Parameter Descriptions for MMC Control on the following pages

**Multiple Motor Control Parameters**

APP▶ Aux Mot Run  
40                    0

Factory Default: 0

This parameter is a display only parameter and displays how many auxiliary motors are being run by MMC control.

APP▶ Starting Aux  
41                    1

Factory Default: 1

This parameter selects which motor starts first (i.e. which auxiliary relay closes first).

APP▶ Auto Op Time  
42                    00:00

Factory Default: 00:00

This parameter displays the operation time (run time) since last Auto Change was accomplished.

APP▶ Nbr Aux's  
43                    4

Factory Default: 4

Sets the number of auxiliary motors connected to the drive.

**APP-44~47: Start Frequency of Aux. Motor 1~4**

For each auxiliary motor, select a frequency (of the running main motor) to turn on the auxiliary motors.

APP▶ Start freq1  
44                    49.99 Hz

Factory Default: 49.99 Hz

APP▶ Start freq2  
45                    49.99 Hz

Factory Default: 49.99 Hz

APP▶ Start freq3  
46                    49.99 Hz

Factory Default: 49.99 Hz

APP▶ Start freq4  
47                    49.99 Hz

Factory Default: 49.99 Hz

The drive turns on AUX1, AUX2, AUX3, and AUX4 if the output frequency is over the frequencies set in APP-44 to APP-47, the delay time APP-58 has expired, and the difference between reference and feedback value exceeds the value set in APP-71 [Aux Start Diff].

**APP-51~54: Stop Frequency of Aux. Motor 1~4**

APP▶ Stop freq1  
51                    20.00 Hz

Factory Default: 20.00 Hz

APP▶ Stop freq2  
52                    20.00 Hz

Factory Default: 20.00 Hz

APP▶ Stop freq3  
53                    20.00 Hz

Factory Default: 15.00 Hz

APP▶ Stop freq4  
54                    20.00 Hz

Factory Default: 15.00 Hz

The drive turns off AUX4, AUX3, AUX2 and AUX1 in this order if the output frequency is below the frequencies set in APP-51 to APP-54, the delay time [APP-59] has expired, and the pressure difference between reference and feedback value decreases below the set value set in APP-72 [Aux Stop Diff].

APP-58: Delay Time before Starting Aux. Motor  
 APP-59: Delay Time before Stopping Aux. Motor  
 APP-60, 61: Accel/Decel time when the number of pumps is increasing/decreasing

APP▶ Aux Start DT  
 58      5.0 sec

Factory Default: 5.0 sec

Sets the delay time before starting the auxiliary motors.

APP▶ Aux Stop DT  
 59      5.0 sec

Factory Default: 5.0 sec

Sets the delay time before stopping the auxiliary motors.

APP▶ Pid AccTime  
 60      2.0 sec

Factory Default: 2.0 sec

APP▶ Pid DecTime  
 61      2.0 sec

Factory Default: 2.0 sec

APP-60 and APP-61 set the acceleration and deceleration time of the Main motor when auxiliary motors are added and removed.

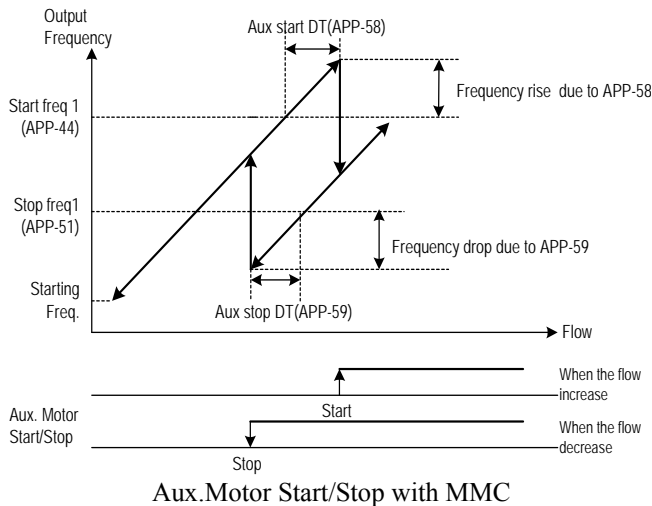

APP-62: PID Bypass Selection

APP▶ Regul Bypass  
 62      No

Factory Default: No

This parameter is used to bypass the PID operation selected in APP-02. Change this parameter to ‘Yes’ when using the MMC function without PID control. The output frequency is determined by actual value (feedback) instead of PID controller output. The actual value is also used as the Start/Stop reference of Aux. motors.

The following figure shows the running pattern with this function applied for controlling the flow rate of a tank. To control the flow rate proportional to the water level of a tank, divide the water level in the tank into the region for the number of Aux. motors plus one, and map each region by starting frequency to maximum frequency. The drive increases output frequency to lower the water level in the tank when the water level in the tank rises. When reaching maximum frequency, the drive connects auxiliary motors as needed. After connecting an auxiliary motor, the drive starts again from the starting frequency. By selecting APP-62 [Regul Bypass] to ‘Yes’, PID operation is disabled and Control Mode is changed to ‘V/F’. PID Bypass is available only when DRV-04 [Freq. Mode] is set to ‘V1’, ‘I’ or ‘Pulse’.

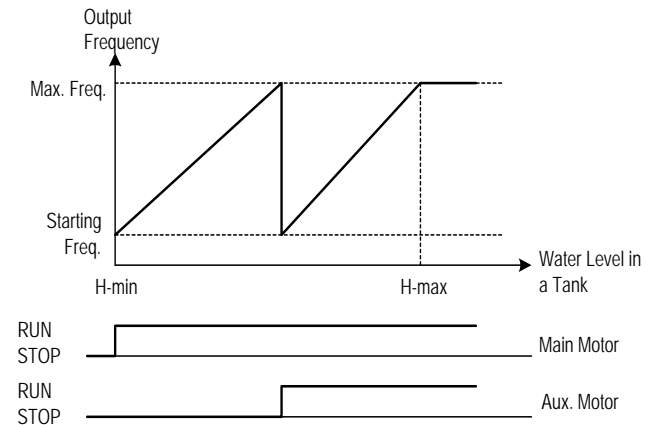

**Steps to use MMC operation**

**A. Set MMC in APP-01**

**B. Set Process PI to Yes in APP-02**

**C. Set Pre PID operation enable/disable**

Related Parameter: APP-74, 75, 76 and 77.

- a. Used for trial operation to check such as pipe damage before operation.
- b. Used to know the starting set point before PID operation

**D. Set PID set point value input method in APP-04**

- a. Keypad, V1, I ...
- b. Set target value

**E. Set PID Feedback input method in APP-06**

- a. Set according to sensor used.
- b. Analog input (4~20mA, 0~10V ...)
- c. Select Units of Process Variable (PSI, percent, etc) in I/O-86.
- d. Scale Feedback with I/O-87 and APP-31, 32 or 33.
  - e. Check whether the setting performs well.
    - i. Pre-operation is needed.
    - ii. Checks whether output to feedback value is generated.

**F. Set Multi-motor driving sequence in APP-66**

- a. Modes EXCH\_NONE and AUX\_EXCH: Main motor and Aux motors used
  - i. Available motor: Main motor 1 + Aux motors 4 (max).
  - b. MAIN\_EXCH Mode: Exchange of Main/Aux motors to drive output
    - ii. Available motor: Aux motors 4 (max).

**G. Set the number of Aux motors in APP-43**

**H. Set the starting Aux motor in APP-41**

**I. Set the start freq of Aux motors in APP-44~47**

**J. Set the stop freq of Aux motors in APP-51~54**

**K. Start operation.**

**Related MMC functions and parameters**

- A. Energy-saving under light load  
Sleep, Wake up APP-63, 64, 65.**

**B. To easily and effectively use Process PID operation, Pre PID APP-74, 75, 76, 77.**

**C. To divide the load to the motor equally  
Auto Change APP-66, 67, 68.**

**D. To associate other conditions with Aux motor operation, INTERLOCK APP-69.**

**E. Adjusting Aux motor ON/OFF condition and output (pressure, air/wind volume) variation  
Aux Start Diff APP-71  
Aux Stop Diff APP-72.**

**F. To change response characteristics  
PI Control APP-03, 07, 08 and 09.**

APP-63: Sleep Delay Time  
APP-64: Sleep Frequency  
APP-65: Wake-Up Level

APP▶ Sleep Delay  
63      60.0 sec

Factory Default:    60.0 sec

APP▶ Sleep Freq  
64      0.00 Hz

Factory Default:    0.00 Hz

APP▶ WakeUp level  
65      2 %

Factory Default:    2 %

The Sleep function is initiated when output demand is low. The drive stops the motor when the frequency output dips below the Sleep Frequency (APP-64) for the duration of the Sleep Delay Time (APP-63). While in the sleep state, the drive keeps monitoring the process (feedback) and initiates the Wake-Up function when the feedback has decreased below the Wake-Up level (APP-65).



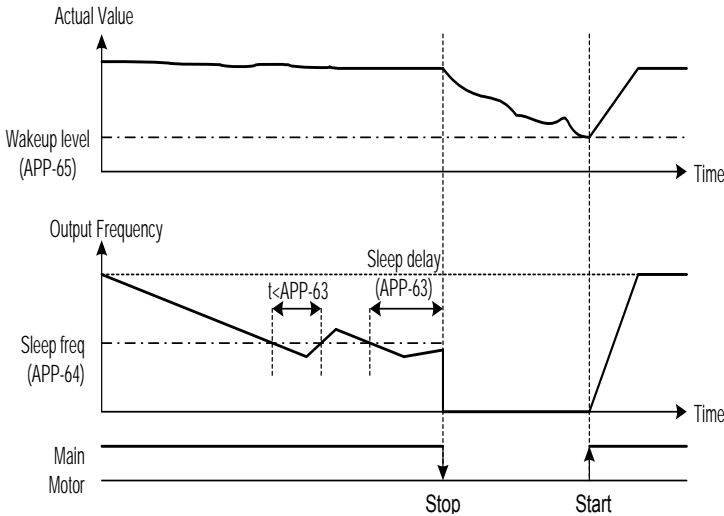

**Note:** Sleep function does not operate if the Sleep Delay Time (APP-63) is set to '0'.

Sleep Operation

**APP-66: Auto Change Mode Selection**

APP▶ AutoCh\_Mode  
66 EXCH\_NONE

Factory Default: EXCH\_NONE

This function is used to change the running order of the motors to regulate and balance their run-times when multiple motors are connected for MMC use.

**EXCH\_NONE Mode:** Auto Change Function Disabled.

The drive is controlling a main motor (permanently connected to output of drive) and activating relays (AUX1~AUX4) to connect Auxiliary motors in a fixed order. For example, starting from the Aux motor 1 (APP-41 = 1), the drive turns the relays ON from **RLY1 → RLY2 → RLY3 → RLY4** and turns off the auxiliary motors from **RLY4 → RLY3 → RLY2 → RLY1**.

**AUX\_EXCH Mode:** Auto Change Function is applied only to aux. motors. Starting of Auxiliary motors is automatically rotated by the drive in AUX\_EXCH Mode to prevent a specific motor from operating more than the other motors. On/Off sequence of auxiliary motors is fixed using EXCH\_NONE Mode but rotates the sequence (alternates) using AUX\_EXCH Mode. For example, when Aux motors running order is presently **RLY1 → RLY2 → RLY3 → RLY4** and the Auto change condition is met, the drive would then turn the relays On from **RLY 2→ RLY3 → RLY4 → RLY1**.

→ EXCH\_NONE and AUX\_EXCH Modes are for use when a Main motor is permanently connected to the output of the drive.

**MAIN\_EXCH Mode:** Auto Change of motors to drive output.

All motors are alternately connected to the drive output via relays/contactors. The sequence operation is the same as AUX\_EXCH Mode, except that there is no main motor permanently connected to output of drive. See Interlock diagram.

**APP-67: Auto Change Time  
APP-68: Auto Change Level**

APP▶ AutoEx-intv  
67 72:00

Factory Default: 72:00 (hh:mm)

APP▶ AutoEx-Freq  
68 20.00 Hz

Factory Default: 20.00 Hz

The Auto Change function is used to prevent one motor from running for a long time by changing operation to another motor.

## Chapter 6 - Parameter Description [APP]

Auto Change is accomplished when the following conditions are satisfied:

The time set in APP-67 is over.

The drive output speed (Hz.) is less than the APP-68 setting.

The difference between the Reference (Set point) and the Feedback signal is greater than the percent set in APP-71.

All Aux motors Off (in **AUX\_EXCH Mode**)  
OR One motor is running (in **MAIN\_EXCH Mode**).

When the above conditions are met, the drive stops the running motor, and changes the motor to run by the order set in APP-66 and then continues operation according to the new run order. The drive starts counting only when the auxiliary motor is running.

In MAIN\_EXCH Mode, when the drive output frequency is below Auto Change Level (APP-68), the drive automatically stops the motor and performs an Auto change function to operate the next motor.

Refer to the wiring example when Interlock is used during Auto change MAIN\_EXCH Mode.

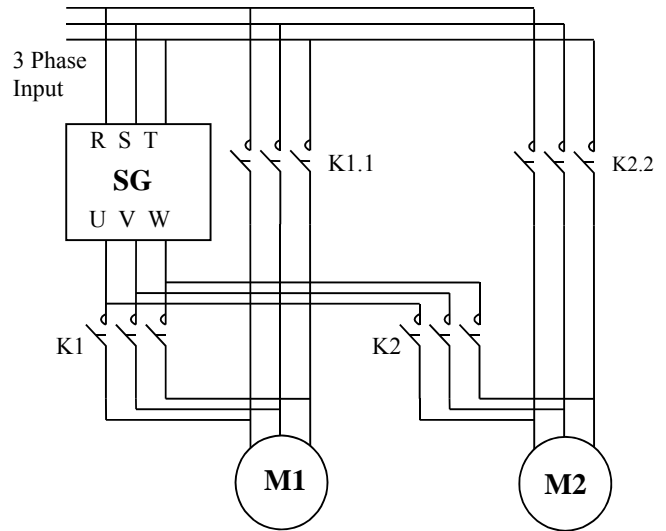

Wiring Diagram for Inter-Lock Configuration

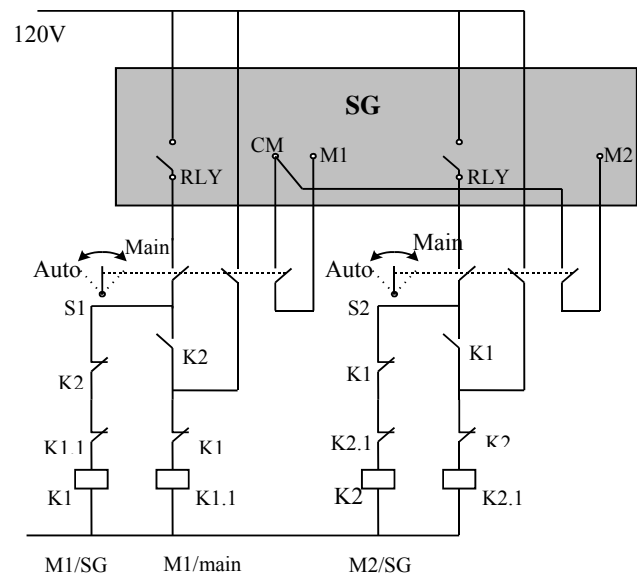

Sequence Circuit for Inter-Lock Configuration

**APP-69: Interlock Selection**

APP▶ Inter-lock  
69 No

Factory Default: No

When APP-69 [Interlock selection] is set to “Yes”, M1~M4 can be used as the same activating condition for AUX1~AUX4. Multi-function input terminals are activated when turned ON. If one of them is turned off, all motors will start running except the motor connected to the off terminal. If the input signal is turned off in the midst of running, drive stops all the motors and restarts the operation with normal active motors.

**Interlock during Stop**

When Run signal is input during Stop, MMC operation is started with all the Auxiliary motors (Relays) available to be turned ON.

Ex) When Interlock is not selected:

**RLY1→RLY2→RLY3→RLY4**

When Interlock is active (the terminal defined as Interlock/RLY2 is turned Off to signify that motor 2 should not run):

**RLY1→RLY3→RLY4**

**Interlock during RUN**

When Interlock is active during RUN (the terminal defined as interlock/RLY is turned Off during RUN), drive stops all motors and restart MMC operation with auxiliary motors except the interlocked one (terminal turned Off).

Ex) Normal operation:

**RLY1→RLY2→RLY3→RLY4**

When Interlock is active (the terminal defined as Interlock/RLY3 is turned OFF), all Aux motors are turned Off and stopped. MMC operation is restarted except Aux motor 3 (RLY 3 Off).

Aux motors start rotating in the order of

**RLY1→RLY2→RLY4.**

**Aux motor starting condition** and output (Pressure, air volume.) adjustment

Drive turns Aux motors ON automatically when it is impossible for a main motor to control increased load, causing shortage in flow rate or pressure. For the drive to turn the On Aux motors (maximum 4), starting frequencies for each motor should be set.

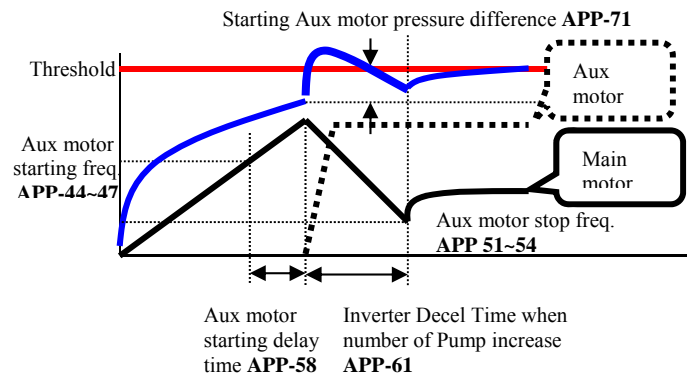

**Aux motor starting condition:** Main motor speed exceeds Aux motor starting frequency (APP-44~47), for the time set in APP-58[Aux motor starting delay time] and the Difference between PID reference and Feedback value exceeds APP-71 [Pressure difference for Aux Motor Start].

**APP-44~47: Frequency to turn Aux motor ON. It is based on the main motor frequency output.**

**APP-58: Should be set greater than system response delay time.**

**APP-71: Set by comparing the pressure difference between the PID reference and the Feedback values to determine when Aux motor is turned ON.**

**APP-61: This is the time the drive frequency is decreased after Aux motor is turned ON. It should be set higher than System delay time because it can cause the Aux motor to run longer than necessary.**

**Aux motor stopping condition** and output (Pressure, air volume) adjustment

Drive turns off the Aux motors when flow rate or pressure is too high due to decreased load. To turn off the Aux motors (maximum 4) automatically, stopping frequencies for each motor should be set.

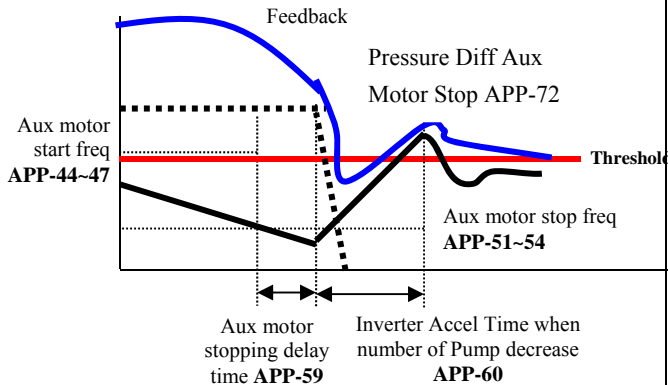

Aux motors are disconnected when the main motor operates at a speed below APP-51~54 [Aux motor stopping frequency] for the time longer than that set in APP-59 [Aux motor stopping delay time] and the pressure difference between the PID reference and the Feedback value exceeds the set value in APP-72 [Pressure difference for Aux Motor Stop].

**APP-51~54: Frequency to turn Aux motors OFF.**  
It is based on the main motor frequency output

**APP-59: Should be set higher than System Delay Time.**

**APP-60: This is the acceleration time that sets how fast the drive frequency is increased after an Auxiliary motor is turned OFF. It should be set higher than System delay time because it can cause the Aux motor to stay off for a longer than desired time.**

**APP-72: Set by comparing the pressure difference between the PID reference and the Feedback values to determine when Aux motor is turned OFF.**

**APP-71: Pressure Difference for Aux Motor Start**  
**APP-72: Pressure Difference for Aux Motor Stop**

APP▶Aux Stt Diff  
71            2%

APP▶Aux Stp Diff  
72            2%

When using MMC control, these parameters set the pressure difference between the PID reference and the Feedback values to determine when the Aux motors are turned On (APP-71) and Off (APP-72).

**APP-74: Pre PID Reference Frequency**  
**APP-75: Pre PID Exit Level**  
**APP-76: Pre PID Stop Delay**  
**APP-77: Pipe Broken**

APP▶ PrePID Freq  
74            0.00 Hz

APP▶ PrePID Exit  
75            0.0 %

APP▶ PrePID dly  
76            600 sec

APP▶ Pipe Broken  
77            No

Pre PID operation is a function for smoother PID operation. For example, before pump operation is started, Pre PID can be used to fill the pump and pipe. It can also be used to clear the pump at low speed before normal operation or to perform Accel/Decel operations before a machine's speed reaches a certain level.

**APP-74** [Frequency before PID operation begins]  
Enter the frequency to run at during Pre PID operation.

**APP-75** [condition to activate PID operation]  
Set the feedback value which when exceeded will allow the start of normal PID operation. If the feedback value exceeds the set value in APP-75, Pre PID operation ends and PID operation begins.

**APP-76** [Pre PID delay time]

Set the time period for Pre PID operation. After this time expires, normal PID control begins.

**APP-77** [Pipe Broken]

When enabled (set to “yes”) if the condition of APP-75 (Pre PID Exit Level) is not met and the delay time APP-76 (Pre PID delay time) has expired, the drive will trip and display “Pipe Broken” fault.

**APP-78: Stopping Order of AUX Motors**  
**APP-79: Stopping Method of AUX Motors**

APP▶ F-in L-out	
78	Yes

APP▶ALL Stop	
79	Yes

**APP-78** [F-in L-out]

When using MMC control, these parameters set the stopping order of the auxiliary motors.

If the starting order is:

Motor #1→Motor #2→Motor #3→Motor #4

When set to “yes” (First In – Last Out), the stopping order is:

Motor #4→Motor #3→Motor #2→Motor #1

When set to “no” (First In – First Out), the stopping order is:

Motor #1→Motor #2→Motor #3→Motor #4

**APP-79** [ALL Stop]

This parameter selects the stopping method of the auxiliary motors when the main motor is stopped.

When set to “yes”, all auxiliary motors will be stopped simultaneously. When set to “no”, the stopping order (APP-78) will be used.

**APP-80~97: External PID operation**

APP▶ Ext PI Mode	
80	No

Factory Default: No

Program APP-80 to “yes” to enable External PID Operation.

Ext PID can be used for ①controlling another system independently as an external PID controller ②using both PID controller in APP-02 and External PID controller ③using Ext PID output as a Drive target frequency. See the diagrams (Case 1, Case 2 and Case 3) on the following pages.

Parameters for External PID Operation, APP-80~96 are the same as those in PID Operation, APP-02~17.

APP▶ Ext Ref Sel	
81	KeyPad

Factory Default: KeyPad

APP▶Ext Ref Perc	
82	50.00%

Factory Default: 50.00%

APP -82 [Ext PID Ref value] is programmable when APP-81 [Ext PID Ref selection] is set to “Keypad”.

**External PID Parameters**

**APP-80 ~ APP-97**

Param	Display	Default	Range
APP-80	Ext PI mode	0 (No)	0 (No) 1 (Yes)
APP-81	Ext Ref Sel	3 (Key-Pad)	0 (I) 1 (V1) 2 (Pulse) 3 (Key-Pad)
APP-82	Ext Ref Perc	50.00 [%]	0 – 100.00 [%]
APP-83	Ext Fbk Sel	0 (I)	0 (I) 1 (V1) 2 (Pulse)
APP-85	ExtPID Pgain	1.0 [%]	0 – 999.9 [%]
APP-86	ExtPID Itime	10.0 [sec]	0 – 32.0 [sec]
APP-87	ExtPID Dtime	0 [msec]	0 – 2000 [msec]
APP-88	ExtPID lmt-H	100.00 [%]	0 – 100.00 [%]
APP-89	ExtPID lmt-L	0 [%]	0 – 30.00 [%]
APP-90	ExtPID Scale	100.0 [%]	0 – 999.9
APP-91	Ext P2-gain	100.0 [%]	0 – 999.9
APP-92	Ext P Scale	100.0 [%]	0 – 100.0
APP-93	ExtPID F-gain	0.0 [%]	0 – 999.9 [%]
APP-95	ExtPIDOut Inv	0 (No)	0 (No) 1 (Yes)
APP-97	Ext Loop Time	100 [msec]	50 – 200 [msec]

APP-97 [Ext PID Loop Time] sets the time to activate Ext PID controller. Set the desired value according to system.

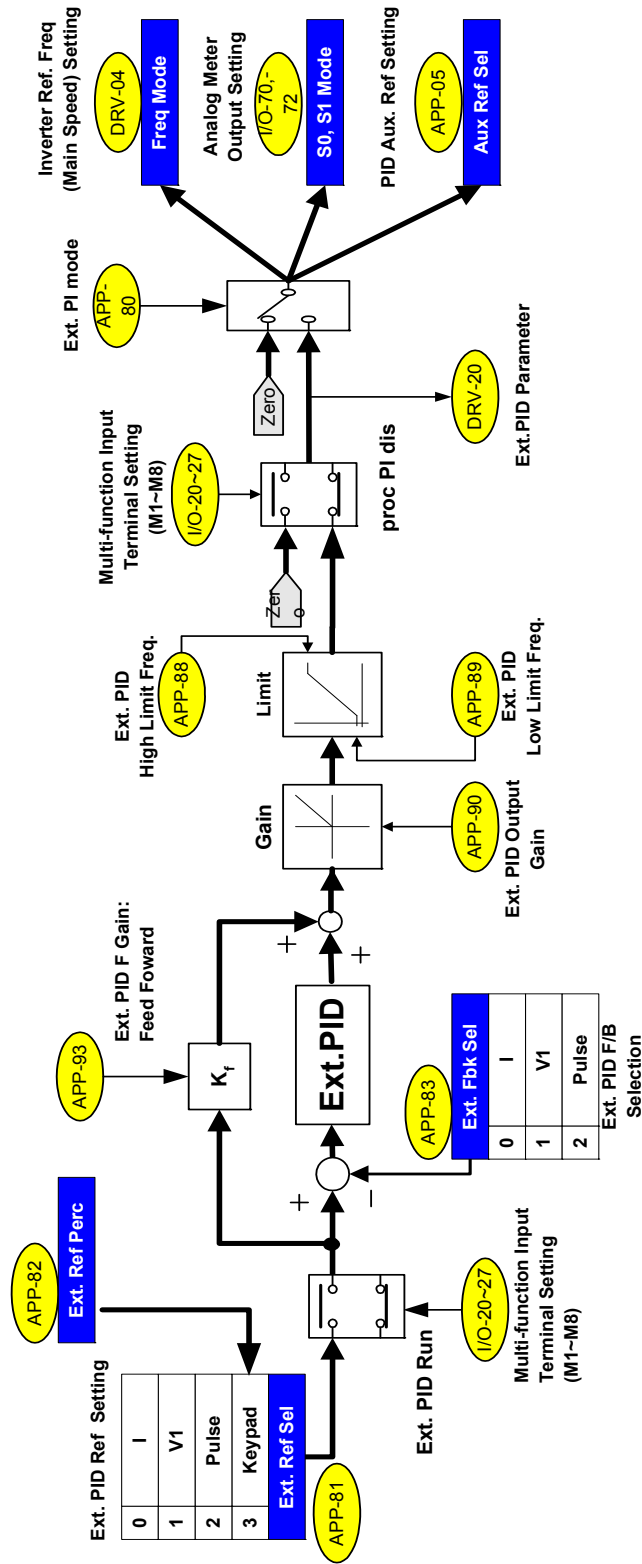

[ Ext. PID block diagram ]

[ Ext. PID internal block diagram]

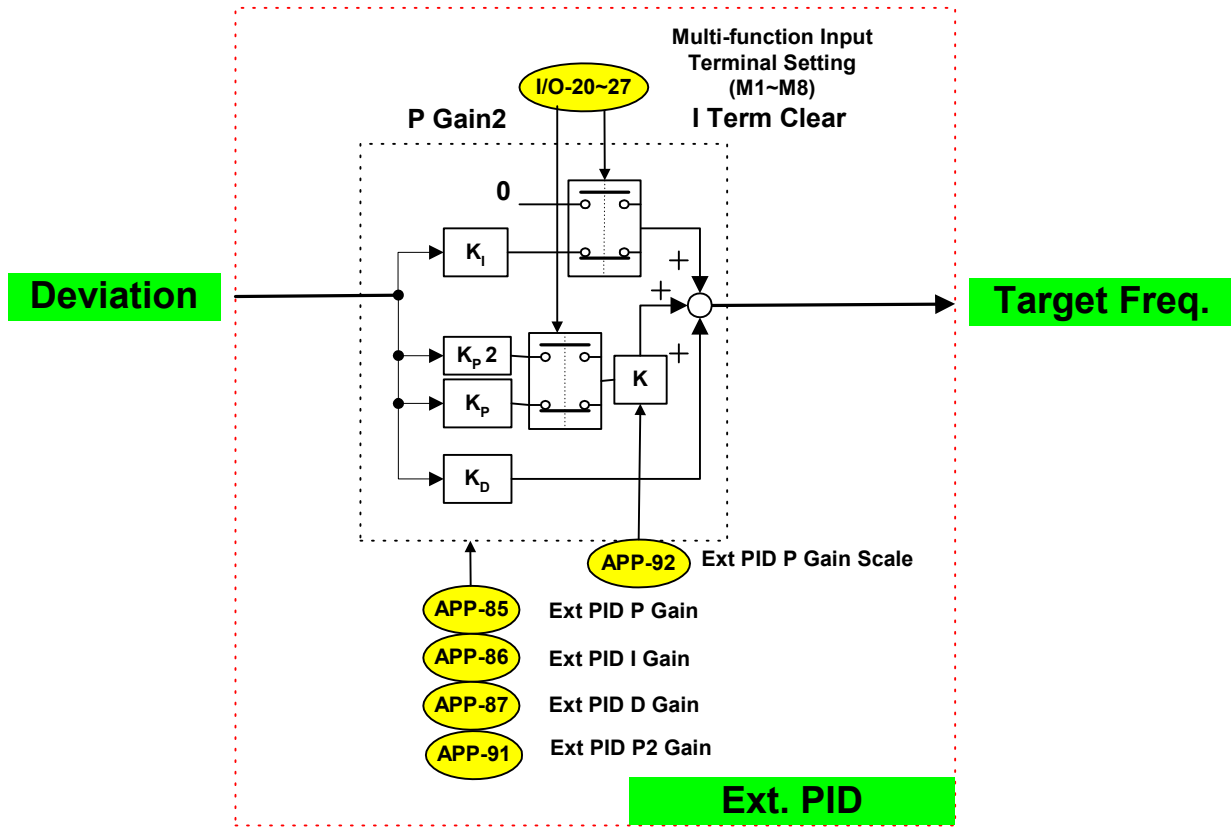



**APP-02 , APP-80 (Dual PID operation)**

ExtPID can be used in the following three cases; 1) controlling another system independently like an external PID controller 2) using both PID controller in APP-02 and External PID controller 3) using ExtPID output as a drive target frequency.

**Case 1: Dual PID block diagram**

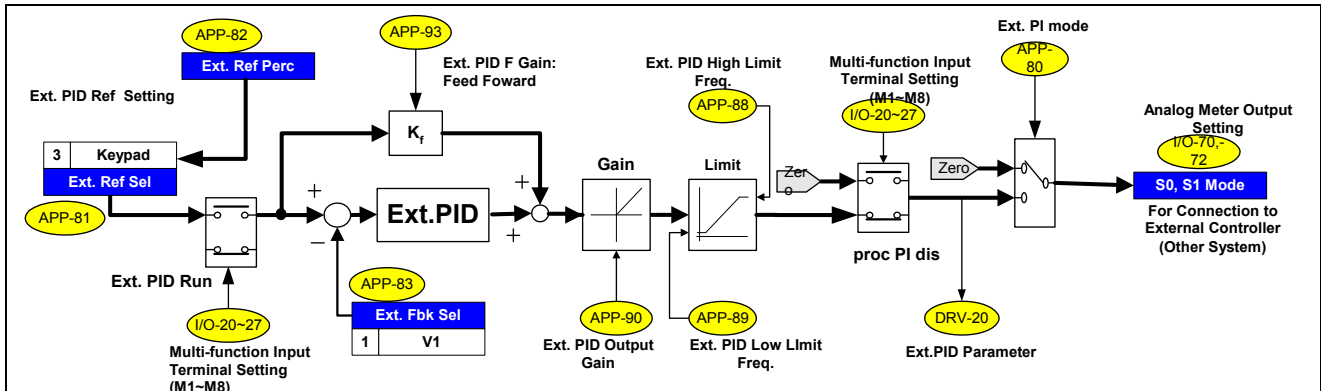

This illustrates controlling another system independently. Set I/O-70 or 72 [S0/S1 mode] to “Ext PID Out” and connect external system to S0 or S1 terminal. When Ext.PID Run signal is ON at the defined terminal in I/O-20~27, it starts its output.

Case 2: Dual PID block diagram

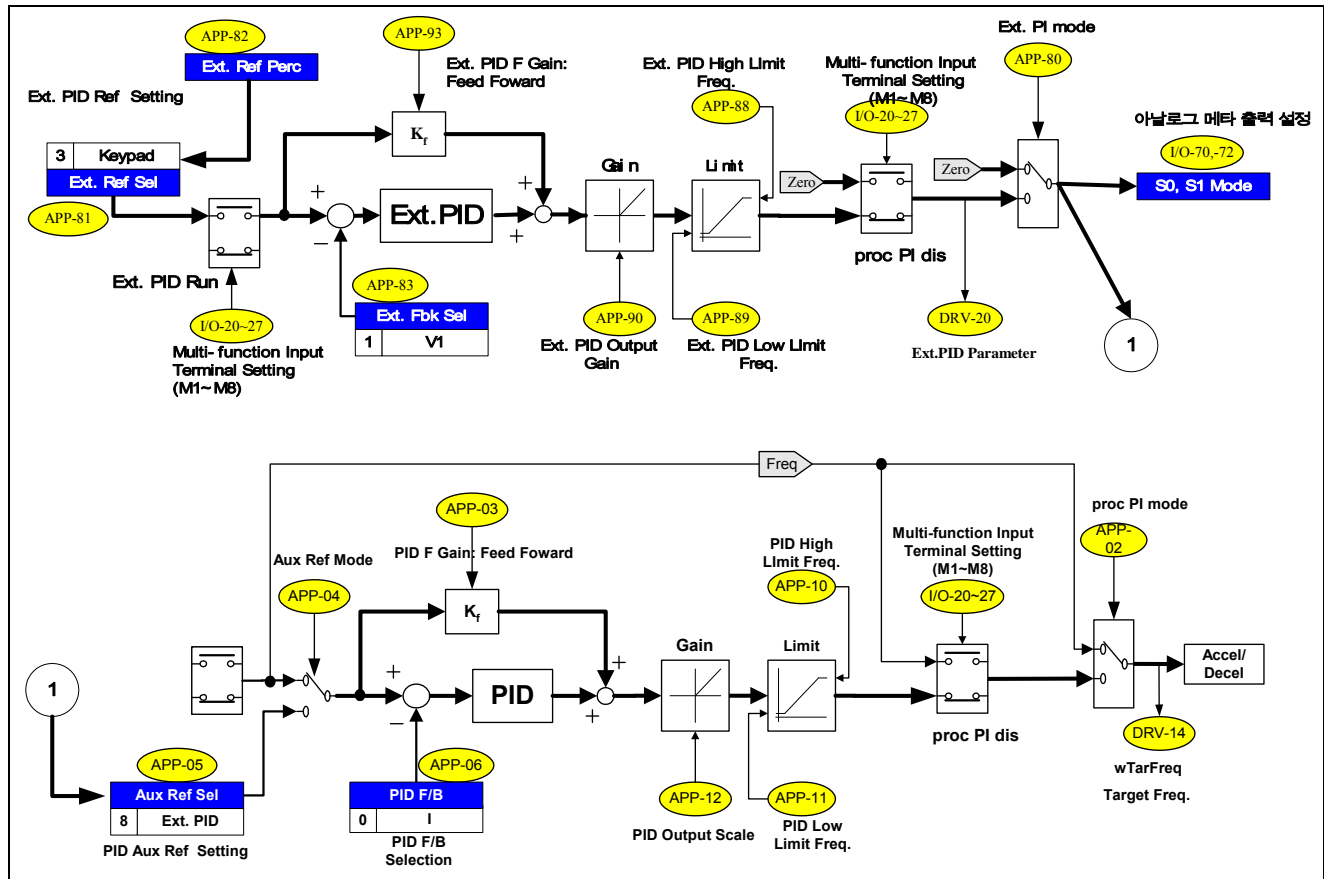

This illustrates dual use of PID controller (APP-02) and External PID controller. Set APP-81 [Ext. Ref Sel] to Analog Input (V1, I, or Pulse) and connect wiring for analog input. To give the digital reference, set APP-81 [Ext. Ref Sel] to “Keypad” and set proper value in APP-82 [Ext. Ref Perc]. Set the Ext. PID Feedback among V1, I, Pulse in APP-83 and connect wiring for analog input. External PID Ref. and feedback are connected to PID controller. When Ext.PID Run signal is ON to the defined terminal in I/O-20~27, it starts its output. S0/S1 terminal can be used to connect to another system.

## Case 3: Dual PID block diagram

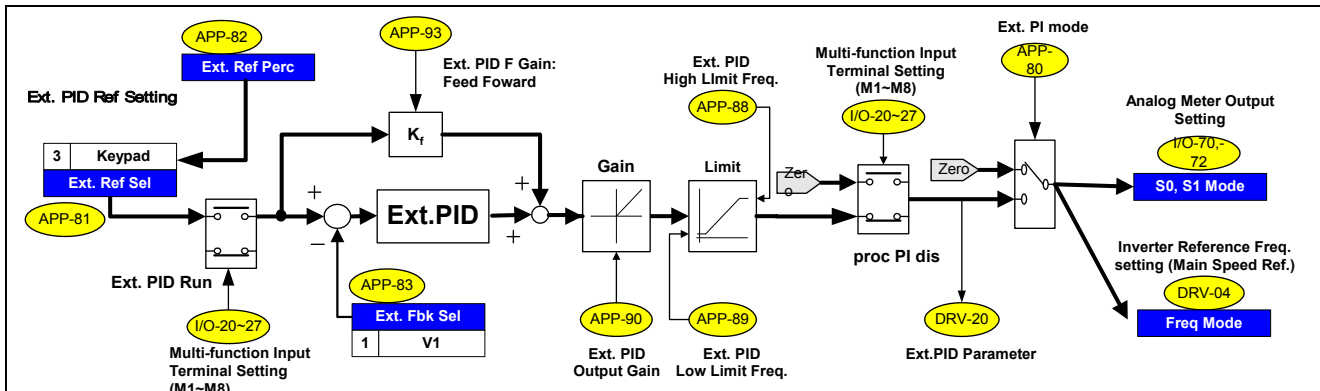

ExtPID output can be used for drive target frequency. To activate this function, set analog input (V1, I, Pulse) as a reference value to other system or set APP-81 [Ext. Ref Sel] to “Keypad” and set proper value in APP-82 [Ext. Ref Perc]. Set APP-83 [Ext. Fbk Sel] to Analog input (I, V1, Pulse) and connect wiring for analog input. Set DRV-04 [Freq Mode] to “Ext. PID”, then ExtPID output functions as Drive main speed reference (target frequency). When Ext.PID Run signal is ON in the defined terminal in I/O-20~27, it starts its output and drive performs Accel/Decel with output frequency. Another system can be connected via S0/S1 terminal.



## Chapter 7. Trouble Shooting & Maintenance

### 7.1 Fault Display

When a fault occurs, the drive turns off its output and displays the fault status in parameter DRV-13. When the fault is reset, it gets stored in the fault history. The last five (5) faults are saved in the fault history (parameters AFN-01 through AFN-05) along with the drive's speed, status, amps, DC Bus voltage and temperature at the time of the fault. AFN-01 is the most recent fault.

LCD Keypad Display	Protective Function	Description
Over Current 1	Over Current Protection	The drive turns off its output when the output current of the drive is more than 200% of the drive standard duty rated current.
Ground Fault	Ground Fault Protection	The drive turns off its output when a ground fault occurs and the ground fault current is more than a preset value. The over current trip function may also protect the drive when a ground fault occurs due to a low ground resistance.
Over Voltage	Over voltage protection	The drive turns off its output if the DC bus voltage increases higher than the OV Trip level. This occurs when the motor decelerates too quickly or when regenerative energy flows back to the drive due to a regenerative load. This fault can also occur due to a surge generated at the input power supply system. OV Trip Level 230Vac drive ~ 390VDC OV Trip Level 460Vac drive ~ 780VDC OV Trip Level 575Vac drive ~ 980VDC <b>NOTE: OV fault may be displayed when an output short occurs. See Over Current-2 fault.</b>
Over Load	Inverter/Motor Overload Protection	When activated with FUN-66, the drive turns off its output when the output current is greater than 120% (FUN-67 default) for 60 secs. (FUN-68 default). <b>NOTE: See Overload retention at bottom of table.</b>
Over Heat	Inverter Over Heat	The drive turns off its output if the internal thermistor detects an over heat condition due to a damaged cooling fan, a foreign substance blocking the heat sink or cooling fan(s), or operation in a high ambient temperature.
E-Thermal	Electronic Thermal	The internal electronic thermal overload protection of the drive has determined that the motor has over heated. Overload capacity: 130% of DRV-05 for 1 min (DRV-05 ~ DRV-09) <b>NOTE: See Overload Retention at bottom of table.</b>
Ext. Trip	External Trip	Multi-function input configured as "Ext_Trip" has indicated a fault condition. This function is used to turn off the output using an external trip signal. The external trip input can be from an external overload relay, brake resistor temperature switch or other monitoring/safety equipment connected to the drive system.
Low Voltage	Low Voltage Protection	The drive turns off its output if the DC bus voltage decreases below the Low Voltage trip level. LV Trip Level 230Vac drive ~ 200VDC LV Trip Level 460Vac drive ~ 400VDC LV Trip Level 575Vac drive ~ 500VDC <b>NOTE: Insufficient torque and/or over heating of the motor can occur when the output voltage of the drive drops.</b>
Over Current 2	IGBT Short	The drive turns off the output if an output short occurs (motor or cables) or if an IGBT is shorted.

## Chapter 7 – Trouble Shooting & Maintenance

LCD Keypad Display	Protective Function	Description
Output Phase Open	Output Phase Open	The drive turns off its output when the one or more of the output phases (U, V, W) is detected open. Open is defined as less than half of AFN-44, No Load Current. Also, if FUN-57 and FUN-58 are set, open is determined as less than FUN-58 level for 1 second.
Input Phase Open	Input Phase Open	The drive turns off its output when the one or more of the input phases (R, S, T) is detected open.
BX	BX Protection (Drive Disable)	Used as a drive disable function. The drive instantly turns off the output when the BX terminal is activated (ON).
HW-Diag	Inverter H/W Fault	This fault ( <u>HardWare</u> fault) is indicated when there is a component failure internal to the drive. Examples: control circuitry (Wdog error, EEP error), NTC open, Fan Lock, Blown fuse. Also, occurs when no motor is connected. See “No Motor Trip” fault.
COM Error CPU Error	Communication Error	This fault is displayed when the drive cannot communicate with the keypad.
Inv. OLT	Inverter Overload	The drive turns off its output when the output current is more than the rating of the drive. Standard Duty: 110% for 1 minute, 130% for 4 seconds. Heavy Duty: 150% for 1 minute, 162.5% for 4 seconds. <b>NOTE:</b> See Overload Retention at bottom of table.
NTC open	NTC Open	This fault is displayed when the drive internal thermistor is opened (faulty or disconnected).
Ext. OHT	External Over Heat Trip	This fault is displayed when the programmed trip temperature from an externally connected thermistor (PTC or NTC) is exceeded.
Fan Lock (150 HP and above)	Fan Loss	The drive has detected a loss of cooling fan(s).
Fuse Open (40 HP and above)	High Current (Blown Fuse)	Internal fuse detector has activated indicating a blown DC Bus fuse.
No Motor Trip	Low Current	Drive has detected low current or no current flow out of drive.
LOV LOI LOA LOR Lost Cmd	Frequency Reference is Lost	Based on I/O-18 setting, there are four modes of operation after a Loss of Frequency Reference: continuous operation, free run, decelerate to a stop and fault. <b>LOV:</b> Displayed when ‘V1’ analog frequency reference is lost. <b>LOI:</b> Displayed when ‘I’ analog frequency reference is lost. <b>LOA:</b> Displayed when pulsed frequency reference is lost. <b>Lost Cmd:</b> Displayed when any analog signal is lost and I/O-18 is set to “protection”. Based on I/O-92 setting, there are three modes of operation after a Loss of Communications: continuous operation, free run and decelerate to stop. <b>LOR:</b> Displayed when communications frequency reference is lost.
Over Lap (Flashing)	Programming Error	Displayed when more than one digital input terminal (M1 – M8) is programmed to the same function.
Keypad FLT	Loss of Keypad	Keypad disconnected when DRV-26 set to Fault.

To reset fault, Press **RESET** key, close RST-CM terminals or cycle the input power.

**Overload Retention:** The following faults cannot be reset immediately. Overload, E-thermal and Inverter Overload. A cool down period of approximately one minute is required before the drive can be reset.

## 7.2 Fault Remedy

Protective Function	Cause	Remedy
Over Current Protection 1	<ol style="list-style-type: none"> <li>1) Acceleration/Deceleration time is too short compared to the inertial of the load.</li> <li>2) Load is larger than the drive rating.</li> <li>3) Drive turned output on when the motor is still rotating.</li> <li>4) Output short or ground fault has occurred.</li> <li>5) Mechanical brake on the motor is engaging too fast before the drive has actually turned off.</li> <li>6) Components of the main circuit have overheated due to a faulty cooling fan or blocked cooling.</li> <li>7) Power factor capacitors or other filters are connected to output of drive.</li> </ol>	<ol style="list-style-type: none"> <li>1) Increase Accel or Decel time.</li> <li>2) Increase drive capacity.</li> <li>3) Operate only after motor has completely stopped or use speed search function.</li> <li>4) Check output wiring for shorts and ground faults.</li> <li>5) Check mechanical brake operation.</li> <li>6) Check cooling fan.</li> <li>7) Remove capacitors or filters from output of drive.</li> </ol> <p><b>Caution: Operating the drive prior to correcting the original cause of this fault may result in damage to the power section's IGBTs.</b></p>
Ground Fault Current Protection	<ol style="list-style-type: none"> <li>1) A Ground fault has occurred in the output wiring of the drive.</li> <li>2) A Ground fault has occurred in the motor.</li> </ol>	<ol style="list-style-type: none"> <li>1) Check the output wiring of drive for shorts.</li> <li>2) Test and/or exchange motor.</li> </ol>
Over Voltage Protection	<ol style="list-style-type: none"> <li>1) Deceleration time is too short compared to the inertia of the load</li> <li>2) Regenerative load</li> <li>3) Line voltage too high</li> <li>4) Output Short Circuit</li> </ol>	<ol style="list-style-type: none"> <li>1) Increase deceleration time.</li> <li>2) Use dynamic braking /regenerative resistor option if load is regenerative.</li> <li>3) Check line voltage. Verify drive input voltage rating is correct. Reduce input voltage if necessary.</li> <li>4) If OV Fault occurs immediately on start command, check output for short circuit.</li> </ol>
Overload	<ol style="list-style-type: none"> <li>1) Current output is larger than the overload settings.</li> <li>2) Load is larger than drive rating.</li> <li>3) Incorrect drive capacity selected.</li> <li>4) Incorrect V/F pattern or control mode set.</li> </ol>	<ol style="list-style-type: none"> <li>1) Verify settings in FUN-66, 67 and 68.</li> <li>2) Increase capacity of motor and/or drive.</li> <li>3) Select correct drive capacity.</li> <li>4) Select correct V/F pattern or control mode.</li> </ol>
Overheat	<ol style="list-style-type: none"> <li>1) Cooling fan damaged or a foreign substance is blocking fan(s).</li> <li>2) Foreign substance blocking heatsink.</li> <li>3) Ambient temperature high.</li> <li>4) Switching Frequency is too high for given loading and ambient condition.</li> </ol>	<ol style="list-style-type: none"> <li>1) Exchange cooling fans and/or eliminate foreign substance.</li> <li>2) Check for foreign substances blocking heat sink.</li> <li>3) Keep ambient temperature under 40 C.</li> <li>4) Reduce PWM carrier frequency.</li> </ol>

## Chapter 7 – Trouble Shooting & Maintenance

Protective Function	Cause	Remedy
Electronic Thermal (ETH)	<ol style="list-style-type: none"> <li>1) Motor has overheated.</li> <li>2) ETH settings too low.</li> <li>3) Motor operated at low speeds for extended time.</li> <li>4) Incorrect drive capacity selected.</li> <li>5) Incorrect V/F pattern.</li> <li>6) Load is larger than drive rating.</li> </ol>	<ol style="list-style-type: none"> <li>1) Reduce load and/or running duty.</li> <li>2) Verify motor and drive capability and adjust ETH level to a more appropriate level.</li> <li>3) Install a motor cooling fan with a separate power supply and change ETH settings to forced air cooled motor.</li> <li>4) Select correct drive capacity.</li> <li>5) Select correct V/F pattern or operating mode.</li> <li>6) Increase drive capacity.</li> </ol>
External Trip	External Trip has occurred.	<ol style="list-style-type: none"> <li>1) Eliminate trip condition of external circuit connected to external trip terminal.</li> <li>2) Disable external trip input.</li> </ol>
Low Voltage Protection	<ol style="list-style-type: none"> <li>1) Line voltage low.</li> <li>2) Large loads are connected to same line as drive. (welding machine, motors with high starting current connected to the supply line)</li> <li>3) Faulty inline contactor or one open phase at the input side of the drive</li> </ol>	<ol style="list-style-type: none"> <li>1) Check line voltage. Verify drive rating is correct for input voltage.</li> <li>2) Increase line capacity if necessary to prevent low line condition.</li> <li>3) Check for open circuit in wiring, open fuse, or bad contactor on input to drive.</li> </ol>
Over Current 2	<ol style="list-style-type: none"> <li>1) Short has occurred at the output of the drive.</li> <li>2) Acceleration/Deceleration time is too short compared to the inertial of load.</li> <li>3) Short has occurred between the upper and lower IGBT.</li> </ol>	<ol style="list-style-type: none"> <li>1) Check motor and output wiring of drive for short circuits.</li> <li>2) Increase Accel/Decel times.</li> <li>3) Check (ohm) the output IGBT's.</li> </ol>
Output Phase Open	<ol style="list-style-type: none"> <li>1) Faulty contactor on output</li> <li>2) Faulty output wiring</li> <li>3) Incorrect parameter settings (AFN-40, AFN-44).</li> </ol>	<ol style="list-style-type: none"> <li>1) Check contactor at output of drive.</li> <li>2) Check output wiring and connections.</li> <li>3) Verify parameter settings.</li> </ol>
Input Phase Open	<ol style="list-style-type: none"> <li>1) Faulty input contact (breaker, switch, contactor)</li> <li>2) Loss of one or more input phases</li> <li>3) Faulty Input wiring</li> </ol>	<ol style="list-style-type: none"> <li>1) Check continuity of input device</li> <li>2) Check phase voltages</li> <li>3) Check input wiring and connections</li> </ol>
Bx Fault	Multi-function input configured as "Bx" has detected an inverter disable input. This function is used to disable the drive (turn off the output instantly). The Bx input is typically used for a mechanical brake input or an E-Stop.	Check external control circuitry.
H/W Fault	<p>Wdog error (CPU fault)</p> <p>EEP error (memory fault)</p> <p>ADC Offset (current feedback circuit fault)</p> <p>No Motor Connection or Under Current Level setting</p>	Drive internal failure. Contact Benshaw Customer Service for more information.
Communication Fault	<ol style="list-style-type: none"> <li>1) Faulty connection between drive and keypad</li> <li>2) Drive CPU card malfunction</li> </ol>	<ol style="list-style-type: none"> <li>1) Check connector and wiring.</li> <li>2) Replace drive CPU card.</li> </ol>
Inverter Overload	<ol style="list-style-type: none"> <li>1) Load is larger than drive rating.</li> <li>2) Incorrect drive capacity selected.</li> </ol>	<ol style="list-style-type: none"> <li>1) Increase motor and/or drive capacity.</li> <li>2) Select correct drive capacity.</li> </ol>



Protective Function	Cause	Remedy
NTC Open	Internal thermistor has failed open or is disconnected.	125 HP and below, thermistor is internal to IGBT block. Repair is required. 150 HP and above, thermistor is heat sink mounted. Connection is at Main SMPS bd., connector CN7.
Ext. OHT	External Thermistor has reached trip temperature.	Verify motor heating. Check programming of I/O-97 and I/O-98.
Fan Lock (150 HP and above)	1) Possible fan board failure. 2) Each Fan Bd. Monitors the connected fans internal thermal switch to detect a fan failure.	1) Verify power LED is on for each fan bd. 2) Pins 1 & 2 of connectors CN3 and CN4 on the Fan bd.
Fuse Open (40 HP and above)	1) Internal fuse detector has detected a blown DC Bus Fuse. On 500 HP ~ 700 HP, these are line (input) fuses.	1) Check Fuses. 2) Determine cause of high current.
No Motor Trip	1) The drive has detected no current flow out of the drive. 2) The drive has detected a low current level condition.	1) No motor connection 2) Low level of current set by parameters FUN-57, 58 and 59. Disabled with parameter FUN-57 set to "No".
Frequency (Speed) Reference is Lost	Loss of Frequency Reference from: LOV - V1 input LOI - I input LOA - Pulsed input LOR - Remote Communications	Eliminate cause of fault.
Over Lap (flashing)	Displayed when more than one digital input terminal (M1 – M8) is programmed to the same function.	Check parameters I/O-20 ~ I/O-27 for duplication.

### 7.3 Troubleshooting

Condition	Item to Check
The Motor Does Not Rotate.	1) Main circuit inspection: - Is the input (line) voltage normal? (Is the LED in the drive lit?) - Is the motor connected correctly? 2) Input signal inspection: - Check the operating signal input to the drive. - Check the forward and the reverse signal input to the drive? - Check the command frequency signal input to the drive. 3) Parameter setting inspection: - Is the reverse prevention (FUN-01) function set? - Is the Drive mode (DRV-03) set correctly? - Is the command frequency set to 0Hz? 4) Load inspection: - Is the load too large or is the motor jammed? (Mechanical brake) 5) Other: - Is an alarm or fault displayed on the keypad or is the alarm LED lit? (STOP LED blinks)
The Motor Rotates in Opposite Directions.	- Is the phase sequence of the output terminals U, V, W correct? - Is the starting signal (forward/reverse) connected correctly?
The Difference Between the Rotating Speed and the Reference is too Large.	- Is the frequency reference signal correct? (Check the level of the input signal) - Are the following parameter settings correct? Lower Limit Frequency (FUN-34), Upper Limit Frequency (FUN-35), Analog Frequency Gain (I/O-1~10) - Is the input signal line influenced by external noise or ground loops? (Use a shielded wire)
The Drive Does Not Accelerate or Decelerate Smoothly.	- Is the acceleration/deceleration time is set too short a period of time? - Is the load too large? - Is the Torque Boost (AFN-68, 69) value is too high that the current limit function and the stall prevention function do not operate properly?
The Motor Current is Too High.	- Is the load too large? - Is the Torque Boost Value (manual) too high? - Is the motor rated voltage parameter set correctly? - Is the input voltage low?
The Rotating Speed Does Not Increase.	- Is the Upper Limit Frequency (FUN-35) value correct? - Is the load too large? - Is the Torque Boost (FUN-68, 69) value too high that the stall prevention function (FUN-70, 71) does not operate correctly?
The Rotating Speed Oscillates When the Drive is Operating.	1) Load inspection: - Is the load really oscillating? 2) Input signal inspection: - Is the frequency reference signal oscillating or being disturbed by noise? 3) Other: - Is the wiring too long when the drive is utilizing V/F control? (over 500m)

## 7.4 How to Check Power Components



### WARNING

- Turn the power off and wait until the Main DC Bus Electrolytic Capacitors are discharged to a safe level. The voltage between terminal P1-N (or P2-N) should be less than 30VDC.
- Disconnect input (R,S,T) and output (U,V,W) wiring. Proper test results may not be achieved if any of the input or output wiring remains connected.
- A large reading of resistance such as Mega ohms (or OL) will be displayed when the circuit is Open. When the circuit is closed, the resistance values will range from a few ohms to tens of ohms. Sometimes, a circuit will seem to be closed (or give negative resistance readings) due to the meter charging up the electrolytic capacitors within the circuit but high resistance will be eventually be displayed when the capacitors are charged. A zero ohm reading (or short) indicates a bad (shorted) component.
- The measured values may not always be the exact same values depending on modules and tester types however they should be similar.

1) Diode module and IGBT module check (7.5~ 40HP)

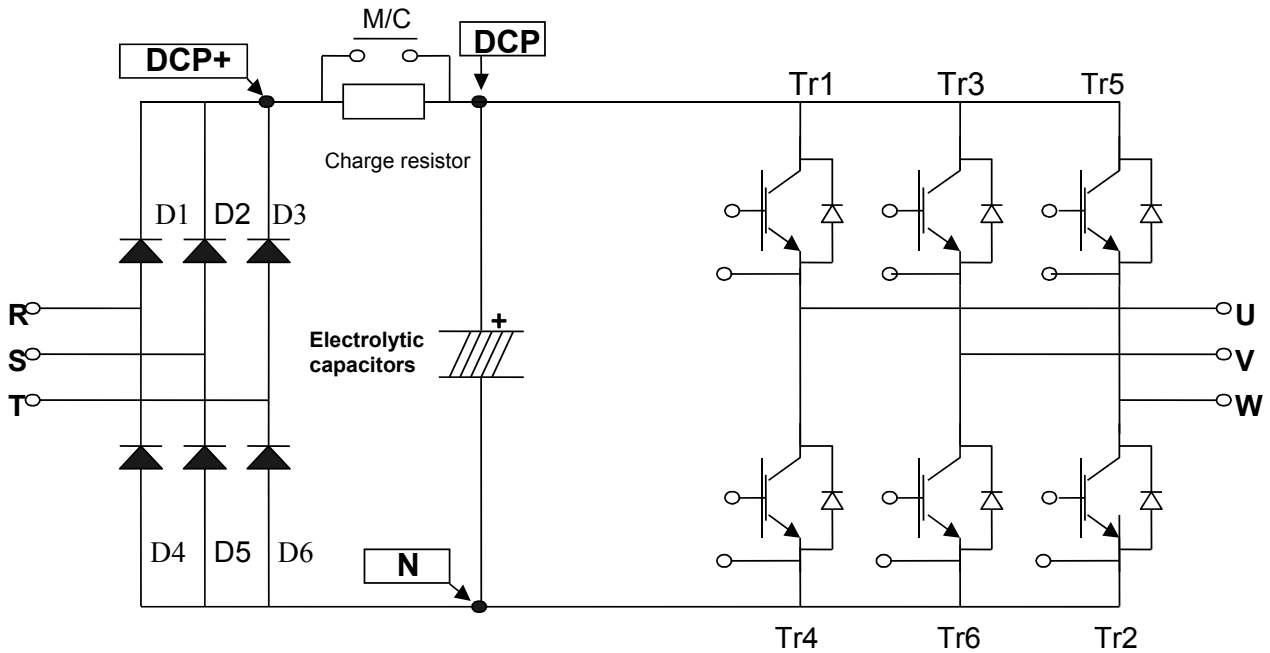

Module		Test polarity		Check value	Number	Test polarity		Check value
		+	-			+	-	
Diode	D1	R	DCP+	Closed	D4	R	N	Open
		DCP+	R	Open		N	R	Closed
	D2	S	DCP+	Closed	D5	S	N	Open
		DCP+	S	Open		N	S	Closed
Diode	D3	T	DCP+	Closed	D6	T	N	Open
		DCP+	T	Open		N	T	Closed
IGBT	Tr1	U	DCP	Closed	Tr4	U	N	Open
		DCP	U	Open		N	U	Closed
	Tr3	V	DCP	Closed	Tr6	V	N	Open
		DCP	V	Open		N	V	Closed
	Tr5	W	DCP	Closed	Tr2	W	N	Open
		DCP	W	Open		N	W	Closed

2) Power Component Check – 50 HP ~ 125 HP

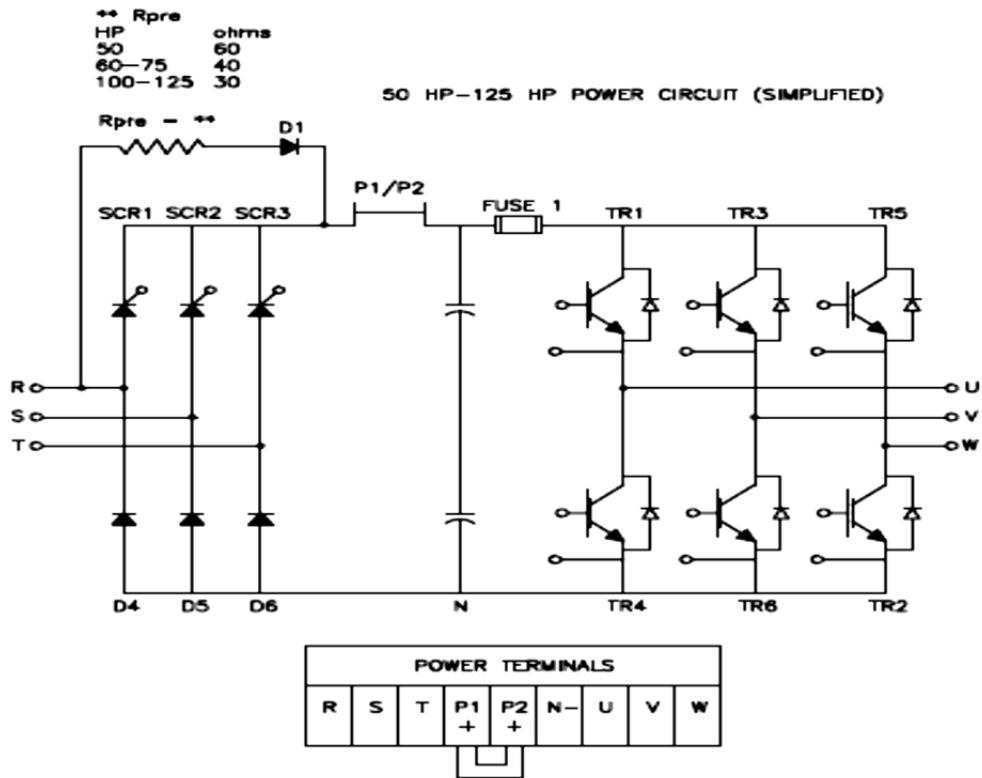

Module	Test polarity		Reading	Module	Test polarity		Reading		
	+	-			+	-			
DC Bus Fuse	Fuse 1	across fuse		Fuse Indicator	Fuse 1	across indicator			
		Closed				Closed			
SCR's	*SCR1 D1	R	P2 (+)	Open	Diodes	D4	R	N (-)	Open
		P2 (+)	R	Open			N (-)	R	Closed
	SCR2	S	P2 (+)	Open		D5	S	N (-)	Open
		P2 (+)	S	Open			N (-)	S	Closed
	SCR3	T	P2 (+)	Open		D6	T	N (-)	Open
		P2 (+)	T	Open			N (-)	T	Closed

\* measurement is across Rpre/D1 (series) in parallel with SCR1

A 125 HP has 6 SCR/Diode modules (SCR1a, SCR2a, D1a, D2a, etc.)

IGBT's	Tr1	U	P2 (+)	Closed	IGBT's	Tr4	U	N (-)	Open
		P2 (+)	U	Open			N (-)	U	Closed
Tr3	Tr3	V	P2 (+)	Closed	Tr6	Tr6	V	N (-)	Open
		P2 (+)	V	Open			N (-)	V	Closed
Tr5	Tr5	W	P2 (+)	Closed	Tr2	Tr2	W	N (-)	Open
		P2 (+)	W	Open			N (-)	W	Closed

3) Power Component Check – 150 HP ~ 250 HP

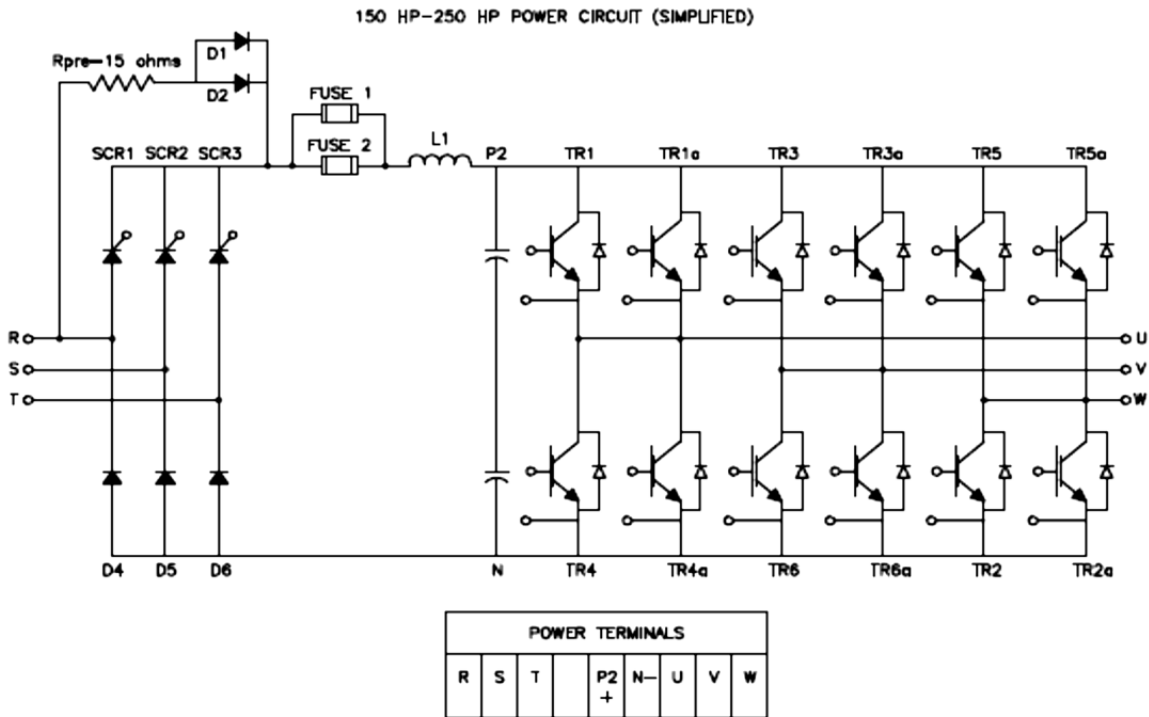

Module	Test polarity		Reading	Module	Test polarity		Reading
	+	-			+	-	
<b>DC Bus Fuses</b>	Fuse 1	across fuse	Closed	<b>Fuse Indicators</b>	Fuse 1	across indicator	Closed
	Fuse 2	across fuse	Closed		Fuse 2	across indicator	Closed

Fuses are in parallel, visual check indicators first

SCR's	SCR	Polarity		Reading	Diodes	Diode	Polarity		Reading
		+	-				+	-	
	SCR1	R	P2 (+)	Open	D4	R	N (-)	Open	
		P2 (+)	R	Open		N (-)	R	Closed	
	SCR2	S	P2 (+)	Open		D5	S	N (-)	Open
		P2 (+)	S	Open			N (-)	S	Closed
	SCR3	T	P2 (+)	Open		D6	T	N (-)	Open
		P2 (+)	T	Open			N (-)	T	Closed

All SCR's have a snubber circuit across them.

IGBT's	IGBT	Polarity		Reading	IGBT's	IGBT	Polarity		Reading
		+	-				+	-	
	Tr1(1a)	U	P2 (+)	Closed	Tr4(4A)	U	N (-)	Open	
		P2 (+)	U	Open		N (-)	U	Closed	
	Tr3(3a)	V	P2 (+)	Closed		Tr6(6A)	V	N (-)	Open
		P2 (+)	V	Open			N (-)	V	Closed
	Tr5(5a)	W	P2 (+)	Closed		Tr2(2A)	W	N (-)	Open
		P2 (+)	W	Open			N (-)	W	Closed

4) Power Component Check – 350 HP ~ 400 HP

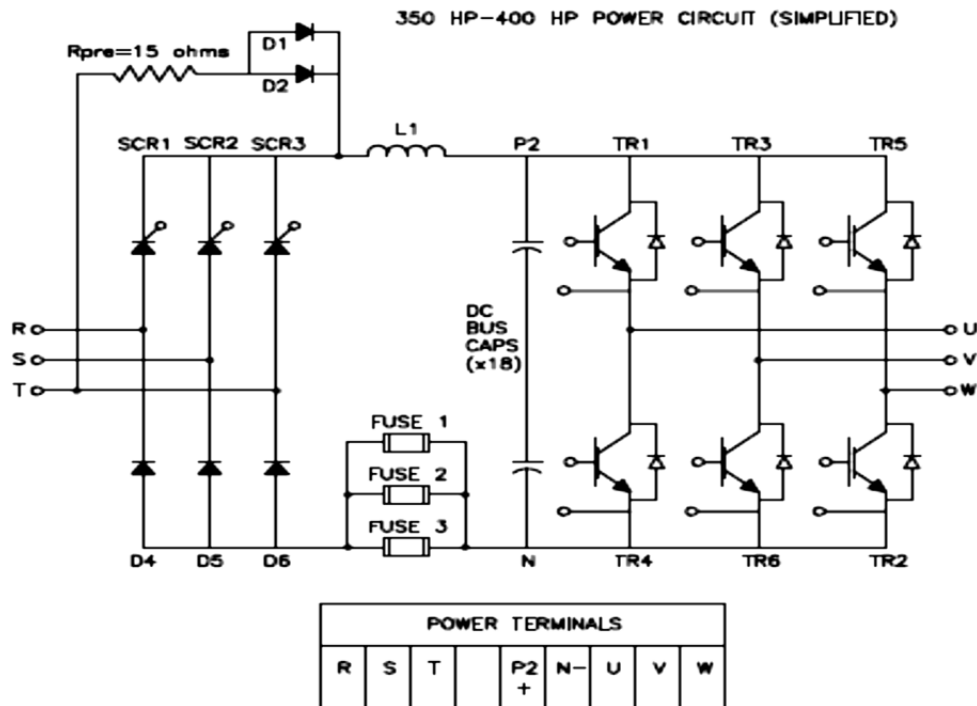

Module		Test polarity		Reading	Module		Test polarity		Reading
		+	-				+	-	
DC Bus Fuses	Fuse 1	across fuse		Closed	Fuse Indicators	Fuse 1	across indicator		Closed
	Fuse 2	across fuse		Closed		Fuse 2	across indicator		Closed
	Fuse 3	across fuse		Closed		Fuse 3	across indicator		Closed

Fuses are in parallel, visual check indicators first

SCR's	SCR	Polarity		Reading	Diodes	Diode	Polarity		Reading
		+	-				+	-	
SCR1	SCR1	R	P2 (+)	Open	D4	D4	R	N (-)	Open
		P2 (+)	R	Open			N (-)	R	Closed
SCR2	SCR2	S	P2 (+)	Open	D5	D5	S	N (-)	Open
		P2 (+)	S	Open			N (-)	S	Closed
SCR3	SCR3	T	P2 (+)	Open	D6	D6	T	N (-)	Open
		P2 (+)	T	Open			N (-)	T	Closed

SCR3: Measurement is D1/D2 and Pre-Charge Resistor

IGBT's	IGBT	Polarity		Reading	IGBT's	IGBT	Polarity		Reading
		+	-				+	-	
Tr1	Tr1	U	P2 (+)	Closed	Tr4	Tr4	U	N (-)	Open
		P2 (+)	U	Open			N (-)	U	Closed
Tr3	Tr3	V	P2 (+)	Closed	Tr6	Tr6	V	N (-)	Open
		P2 (+)	V	Open			N (-)	V	Closed
Tr5	Tr5	W	P2 (+)	Closed	Tr2	Tr2	W	N (-)	Open
		P2 (+)	W	Open			N (-)	W	Closed

5) Power Component Check – 500 HP ~ 700 HP

NOTE: 500 HP DOES NOT HAVE TR1a, TR2a, TR3a, etc.

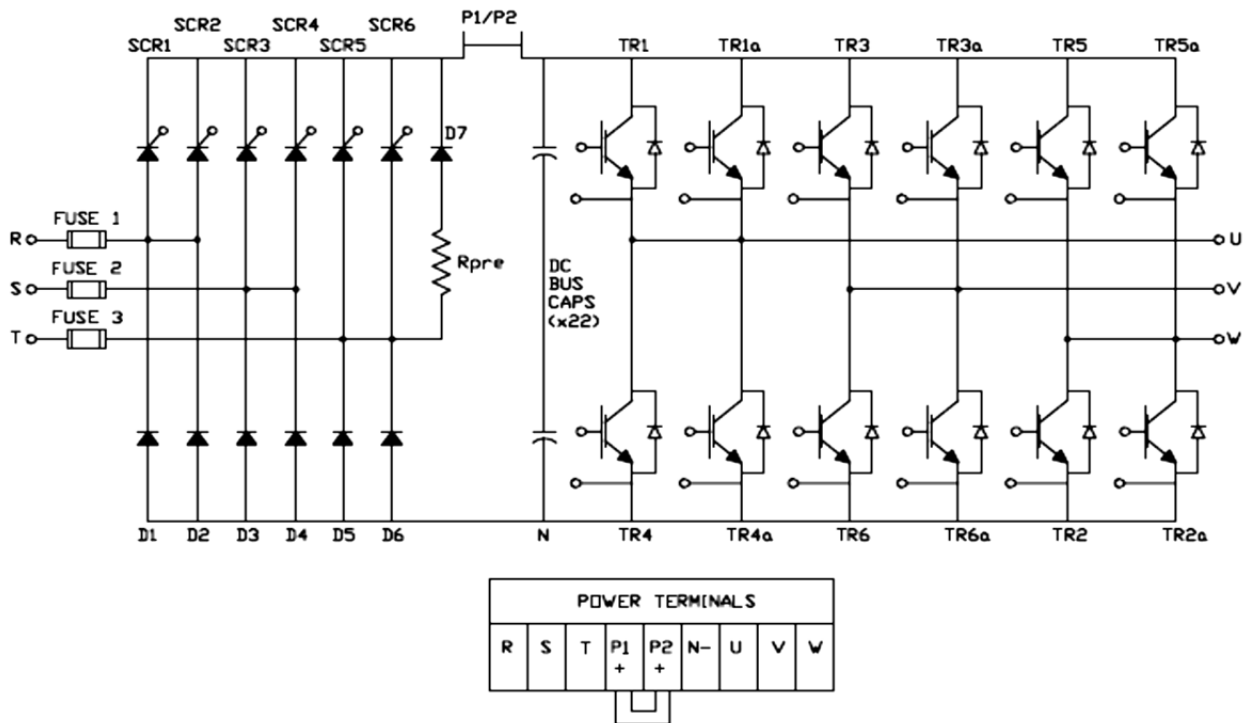

Module		Test polarity		Reading	Module		Test polarity		Reading
		+	-				+	-	
Line Fuses	Fuse 1	R	across fuse	Closed	Fuse Indicators	Fuse 1	across indicator	Closed	
	Fuse 2	S	across fuse	Closed		Fuse 2	across indicator	Closed	
	Fuse 3	T	across fuse	Closed		Fuse 3	across indicator	Closed	

These indicators are connected in series.

SCR's	SCR1/ SCR2	R	P1 (+)	Open	Diodes	D1/ D2	R	N (-)	Open
		P1 (+)	R	Open			N (-)	R	Closed
SCR3/ SCR4	S	P1(+)	Open	D3/ D4	S	N (-)	Open		
	P1(+)	S	Open		N (-)	S	Closed		
SCR5/ SCR6	T	P1(+)	Open	D5/ D6	T	N (-)	Open		
	P1(+)	T	Open		N (-)	T	Closed		

SCR5/6: Measurement is D7 and Pre-Charge Resistor

IGBT's	Tr1(1a)	U	P1(+)	Closed	IGBT's	Tr4(4a)	U	N (-)	Open
		P1(+)	U	Open			N (-)	U	Closed
Tr3(3a)	V	P1(+)	Closed	Tr6(6a)	V	N (-)	Open		
	P1(+)	V	Open		N (-)	V	Closed		
Tr5(5a)	W	P1(+)	Closed	Tr2(2a)	W	N (-)	Open		
	P1(+)	W	Open		N (-)	W	Closed		



## 7.5 Maintenance

The Benshaw series of drive's (Models SG, S4 and GX) are an industrial electronic product with advanced semiconductor components. A reasonable life expectancy of 8 to 10 years can be expected. However, there are factors that may affect their continued long term operation. Environmental issues (temperature and humidity) and mechanical issues (vibration and connections) are the most common reasons for premature failure of drives. To avoid problems, it is recommended to perform routine inspections of the drive.

### 7.5.1 Precautions

- 1) Be sure to remove the drive's power input while performing maintenance. Lock out all sources of power.
- 2) Preventive maintenance should always be performed by a trained technician.
- 3) Be sure to perform maintenance only after checking that the DC bus voltage has discharged. The voltage between terminal P1-N (or P2-N) should be less than 30VDC. The DC bus capacitors in the electronic circuit can still be charged even after the power is turned off. The DC bus LED is not a definitive indication of the absence of DC voltage.

### 7.5.2 Periodic Inspection Summary

Refer to the attached Table for specific frequency of inspection

- 1) The conditions of the installed location
  - a) Observe any physical damage to enclosure or enclosure degradation.
  - b) Any signs of liquid leakage into the enclosure.
  - c) Any signs of corrosion or rust resulting from leakage into the enclosure.
- 2) The conditions of the drive cooling. Causes for abnormal heating are:
  - a) Check for any deposits or dirt inside the enclosure, in the cooling fans/filters and the drive fan(s). Remove with compressed air.
  - b) Check the rotating condition of the cooling fan(s)
- 3) Abnormal vibration
  - a) Are there any loose nuts or bolts as a result of the vibration?
  - b) Loose connections will show signs of heated connectors and wires. Tighten or replace.

7.5.3 Periodic Inspection

	Inspection Item	Inspection	Period			Inspection Method	Criterion	Customer use Check/ Initial /Date
			Monthly	1 year	2 year			
<b>Environment</b>	Ambient Temperature/Humidity	Is the ambient temperature and humidity adequate?	X			Measure/Monitor (Thermometer, Hygrometer, Recorder)	Temperature: -10~+40C	
							Humidity: Under 90% non-condensing	
<b>Physical Inspection</b>	Physical	Any signs of physical damage to the enclosure of the drive?		X		Visual	Yes/No	
		Any signs of liquid leaking into enclosure of the drive?		X				
		Are there any signs of rust inside the drive enclosure?		X				
		Are there any signs of rust inside the panel where the drive is housed.?		X				
		Are there any abnormal vibrations or oscillations of the drive/Panel?		X				
	Physical (Cables and Connections)	Are there any signs of overheated connections (discolored lugs, insulation melted)?		X		Visual	Yes/No	
		Are there any signs of rusted or corroded connections?		X				
		Are there any signs of cracked terminal blocks?		X				
		Is there any damage to cable insulation?		X				
	Physical (Fans)	Inspect fans and filters for dust accumulation/debris.	X					
Inspect fans for free rotation.		X						
<b>Non-Powered Drive Checks/Measurements</b>	IGBT Module	Check the resistance between each of the terminals.			X	Disconnect the drive three phase input and measure the resistance between R, S, T and P, N.	Refer to "How to Check Power Components" using Digital or Analog meter.	
	Input Diode/SCR Modules					Disconnect the drive three phase output and measure the resistance between U, V, W and P, N.		
DC Bus Capacitors	Is there any liquid coming out?			X	Visual check	Yes/No		
	Is the safety pin (pressure relief) out, or is there any swelling?			X				

	Inspection Item	Inspection	Period			Inspection Method	Criterion	Customer use Check/ Initial /Date
			Monthly	1 year	2 year			
Powered drive - Not Running Operating Checks/Measurements	Input Voltages	Is the input voltage from the main within spec of the drive?		X		Measure the voltage between the terminals R, S, T.	drive rating +/- 15%	
		Is the input voltage from the main balanced within spec of the drive?			X		2%	
	DC Bus Voltage	Is the DC Bus Higher or Lower than normal?			X	Measure the DC Voltage between the Pos. and Neg. terminals of the drive.	Input Voltage x SQRT2 (+/- 10%)	
	Cooling Fan	Is there any abnormal oscillations or noise?		X		Turn OFF the power and turn the fan by hand.	Must rotate smoothly.	
	Trip Circuit (Input to drive)	Is drive trip circuit functional?		X		Identify the drive input trip circuit. Open or Close external trip mechanism.	drive must trip.	
Powered Drive - Running Operating Checks/Measurements	Output Voltages	Is there any voltage imbalance between phases of the output?			X	Measure the voltage between the output terminals U, V and W.	for 230V (4V) for 460V (8V) for 600V (12)	
		Does the displayed Output Voltage agree with measurement?			X	Display parameter for Output Voltage, compare to measured value.	Tol. -10%+20% Note 1	
	Output Current	Is there any current imbalance between phases of the output?			X	Measure the current out of each phase U, V, W.	Tol. +/-3% Note 1	
		Does the displayed Output Current agree with measurement?			X	Display parameter for Output Current, compare to measured value.	Tol. +/-5% Note 1	
	General	Are there any abnormal vibrations or noise?		X		Auditory, sensory, visual check.	Yes/No	
		Is there any unusual odor?		X		Check for overheat and damage.	Yes/No	

Note 1 Multimeter measurements of drive output could vary depending on the type of meter.

### 7.5.4 Parts Replacement

Part name	Period	Comments
Cooling fans	2-3 years	Exchange for a new fan after consulting Benschaw customer service center.
Electrolytic capacitors	5 years	Perform periodic inspections every year. Exchange after testing and consulting Benschaw customer service center.  The Recommended capacitance level to replace a capacitor in the main/control circuit is when it has 85% or less of its initial value of capacitance.
Relays / Contactor	-	Exchange for a new part after consulting Benschaw customer service center.

---

■ Notes :

## Chapter 8. Options

### 8.1 Available Options

Item	Description	Part Number
LCD Keypad/Display	32 character Display/Keypad. Download and Upload capability	LCD-100000-00 Standard with all units
Remote Keypad/Display cable	2m, 3m and 5m long keypad cables to mount the standard Display/Keypad remotely from the drive.	VFD-2M-RE-CABLE-SG VFD-3M-RE-CABLE-SG VFD-5M-RE-CABLE-SG
Remote Keypad Bezel	Bezel for Remote Keypad mounting	VFD-KEYPAD-SG-BEZEL
Keypad Blank Insert/Cover	Blank Filler Keypad (at drive) when using remote Keypad	VFD-KEYPAD-SG-BLANK
Analog Output Option card, (0)/4 – 20 mA Outputs	Adds (2) programmable (0)/4 – 20 mA Outputs.	VFD-RSI-SG-4-20-mA
DeviceNet Communications	Enables drive to be connected to a DeviceNet network.	VFD-RSI-SG- DEVICENET
Profibus Communications	Enables drive to be connected to a Profibus network.	VFD-RSI-SG-PROFIBUS
BACnet Communications	Enables drive to be connected to a BACnet network.	VFD-RSI-SG-BACNET
LonWorks Communications	Enables drive to be connected to a LonWorks network.	VFD-RSI-SG-LONWORKS
Modbus TCP	Enables drive to be connected to an Ethernet network.	VFD-RSI-SG-MODBUS-TCP
Dynamic Brake Unit	A Brake Unit and a Resistor enables drive to decelerate rapidly and handle regenerative loads.	See Section 8.1.6 Contact Benshaw for Sizing of Brake Units and Brake Resistors
Dynamic Brake resistors		
Conduit box for NEMA TYPE 1	Installed to satisfy NEMA TYPE 1 Enclosure.	Included with drives up to 125 HP. Not available for 150 HP and above. See section 8.1.8

**8.1.1 LCD Keypad**

For Replacement or Remote Mounting - Part # LCD-100000-00

LCD Keypad (Weight: 140 g)

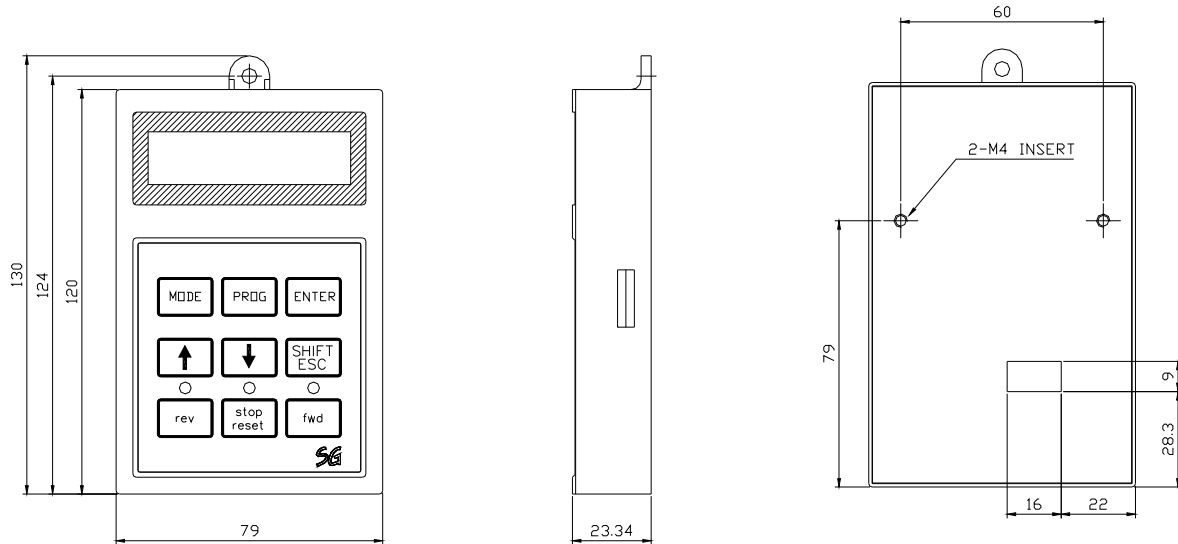

**8.1.2 Remote Keypad Cable**

Part #	Description
VFD-2M-RE-Cable-SG	2m (6.6ft) Remote cable
VFD-3M-RE-Cable-SG	3m (9.9ft) Remote cable
VFD-5M-RE-Cable-SG	5m (16.5ft) Remote cable

**8.1.3 4 – 20 mA Output Option Card**

Part # VFD-RSI-SG-4-20-MA, Manual # 890027-11-xx.

This option card adds (2) isolated outputs (0/4 – 20 mA) to the drive. See the EXT Group of parameters.

**8.1.4 DeviceNet Communications Option Card**

Part # VFD-RSI-SG-DEVICENET, Manual # 890027-05-xx. EDS file required. This option card enables the SG drive to be connected to a DeviceNet network.

### 8.1.5 Profibus Communications Option Card

Part # VFD-RSI-SG-PROFIBUS, Manual # 890027-06-xx. GSD file required. This option card enables the SG drive to be connected to a Profibus network.

### 8.1.6 BACnet Communications Option Card

Part # VFD-RSI-SG-BACNET. This option card enables the SG drive to be connected to a BACnet network.

### 8.1.7 LonWorks Communications Option Card

Part # VFD-RSI-SG-LONWORKS. This option card enables the SG drive to be connected to a LonWorks network.

### 8.1.8 Modbus TCP Option Card

Part # VFD-RSI-SG-MODBUS-TCP. This option card enables the SG drive to be connected to an Ethernet network.

### 8.1.9 Dynamic Braking Unit

In cases where a short stopping time is desired or a high inertia or regenerative load requires dynamic braking capability, an optional Dynamic Braking (DB) unit can be added to the SG drive. Contact Benschaw for more information regarding this option. Dynamic Brake Resistors are NOT included with the DB Unit.

#### 1) Dynamic Braking Unit Models

Input voltage	Drive capacities	DB Unit	Dimensions
230V	1 ~ 20 HP	VFD-RSI-DBU-020-2	Refer to 4)
	25 ~ 30 HP	VFD-RSI-DBU-030-2	
	40 HP	VFD-RSI-DBU-050-2	
460V	1 ~ 20 HP	VFD-RSI-DBU-020-4	
	25 ~ 30 HP	VFD-RSI-DBU-030-4	
	40 ~ 50 HP	VFD-RSI-DBU-050-4	
	60 ~ 75 HP	VFD-RSI-DBU-075-4	
	100 HP	VFD-RSI-DBU-100-4	
> 100 HP	Contact Benschaw		

The units listed in the table above are 230V and 460V, 10% duty cycle brake units. If application requires heavy duty brake modules and resistors or for use with a 600V VFD, contact Benschaw for sizing and selection.

## Chapter 8 – Options

### 2) DB Unit Terminal layout

CM OH

G B2 B1 N P

Terminals	Description
G	Ground terminal
B2	Connect to DB Resistor's B2
B1	Connect to DB Resistor's B1
N	Connect to drive terminal N
P	Connect to drive terminal P1
CM	Over Heat Common
OH*	Over Heat Trip output terminal (Open Collector output: 20mA, 27V DC)

### 3) Wiring for DB unit and DB resistor (for 7.5~40HP drives, 50HP~125HP similar)

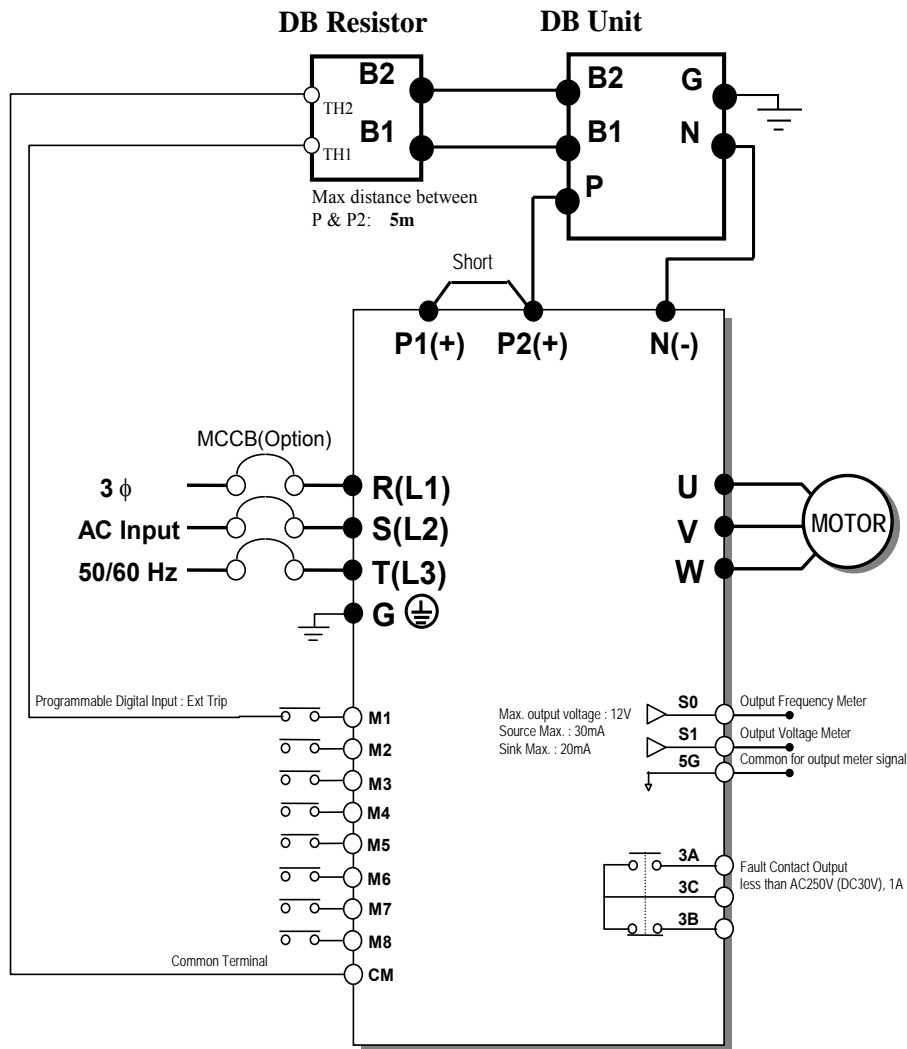



4) Dynamic Brake Unit Dimensions

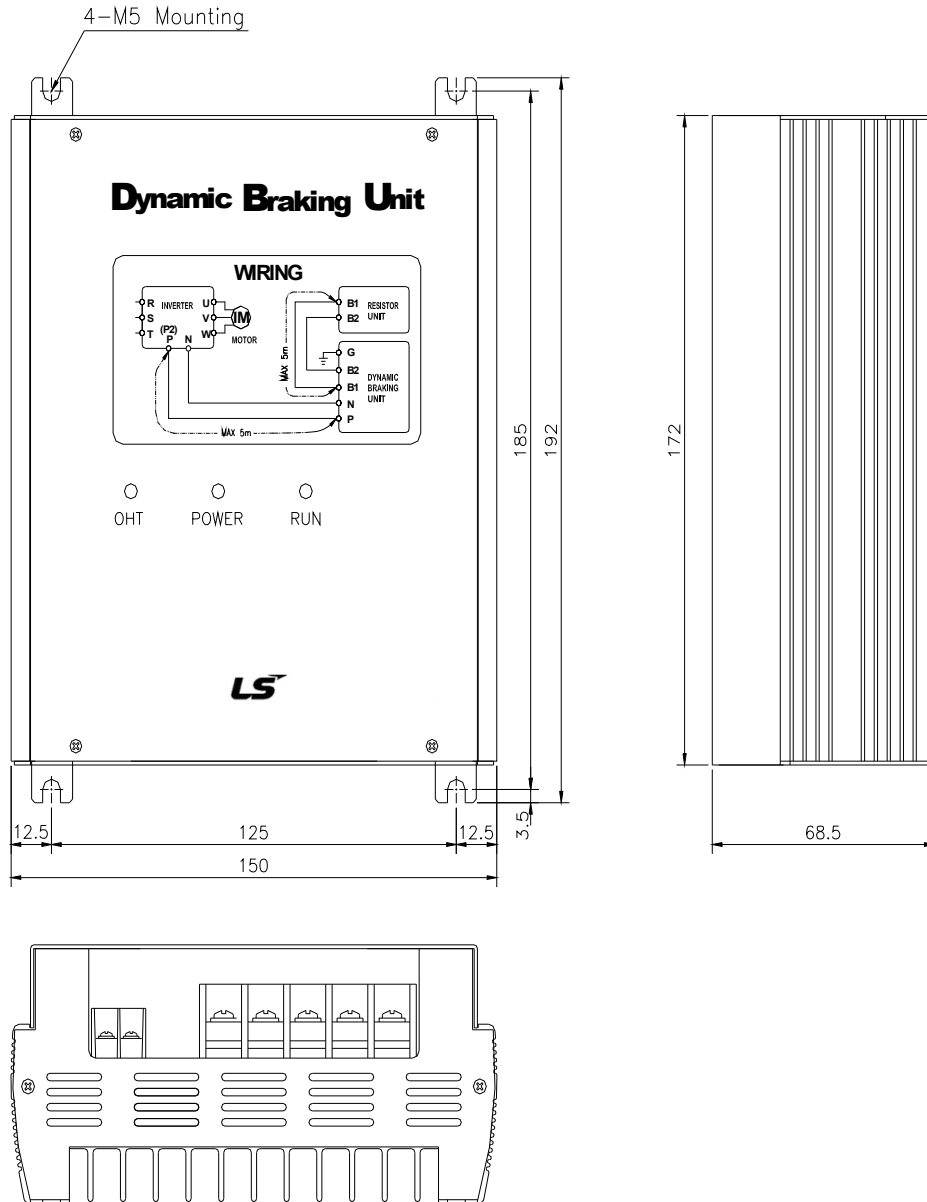

5) DB Unit Monitoring LEDs

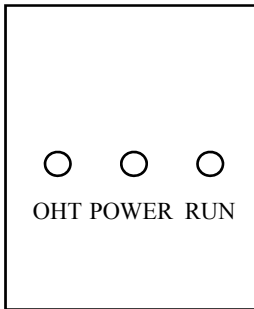

<b>LED</b>	<b>Description</b>
OHT (GREEN, LEFT)	When heat sink is overheated the overheat protection is activated and the OHT LED is turned ON.
POWER (RED)	The POWER LED is turned ON upon inverter Power is ON.
RUN (GREEN, RIGHT)	The RUN LED will blink when the DB Unit is operating normally.

**8.1.10 Dynamic Braking Resistor(s)**

The RSI-SG drive does not contain a built-in dynamic braking transistor or resistor. Benschaw offers a wide selection of resistor options depending on drive size, enclosure requirements, and desired braking duty cycle. Contact Benschaw for more information regarding the sizing and selection of dynamic braking resistors.

**8.1.11 NEMA TYPE 1 Conduit Box**

The NEMA TYPE 1 Conduit Box enclosure enables an SG drive to be installed on the wall without any additional enclosures and satisfy NEMA Type 1 requirements. The conduit box is included with drives 125 HP and below. Drives 150 HP and above do not have a conduit box. See details on the following pages.

Figure A. Conduit Boxes for 20 HP ~ 40 HP

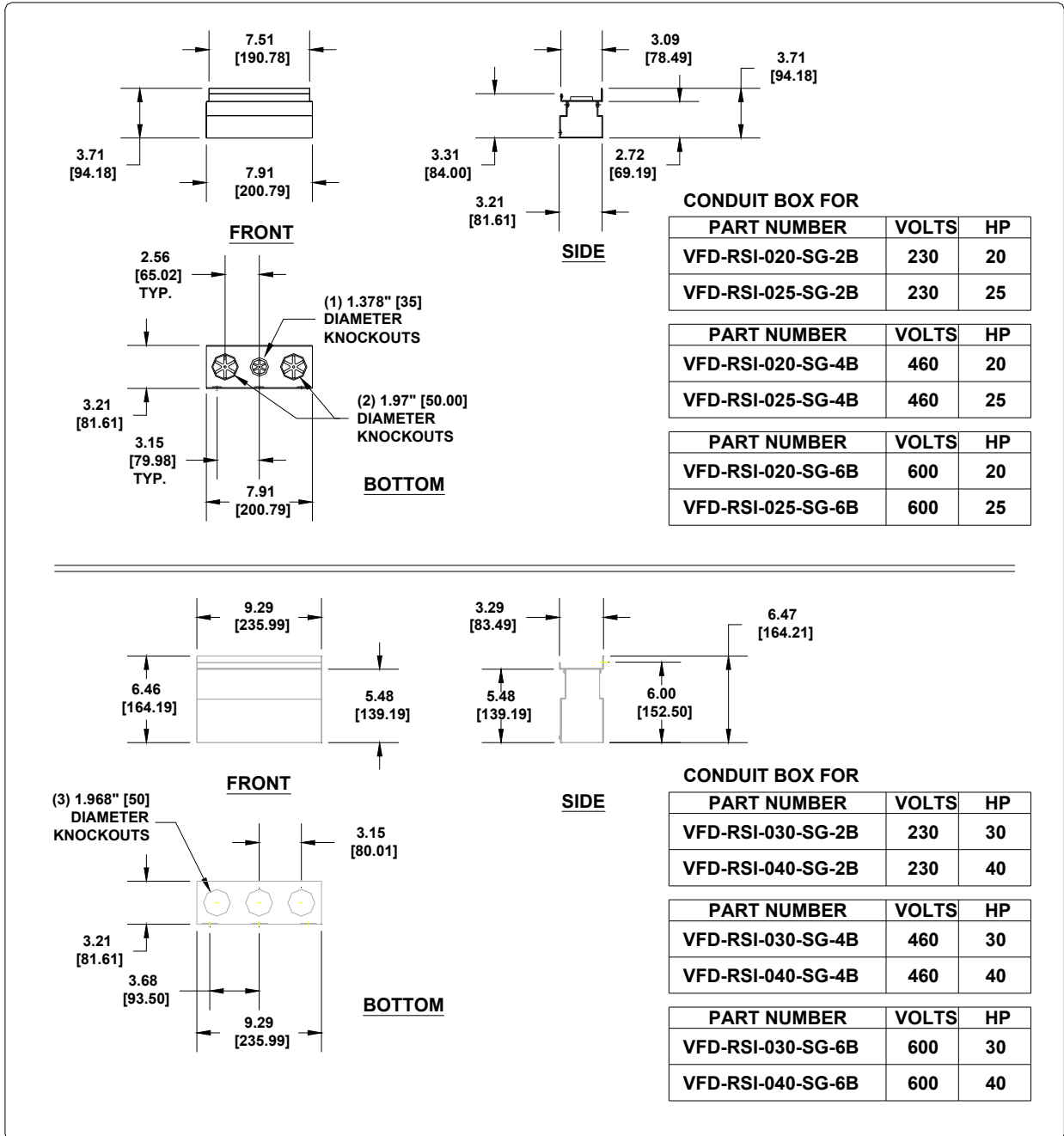

Figure B. Conduit Boxes for 50 HP ~ 75 HP

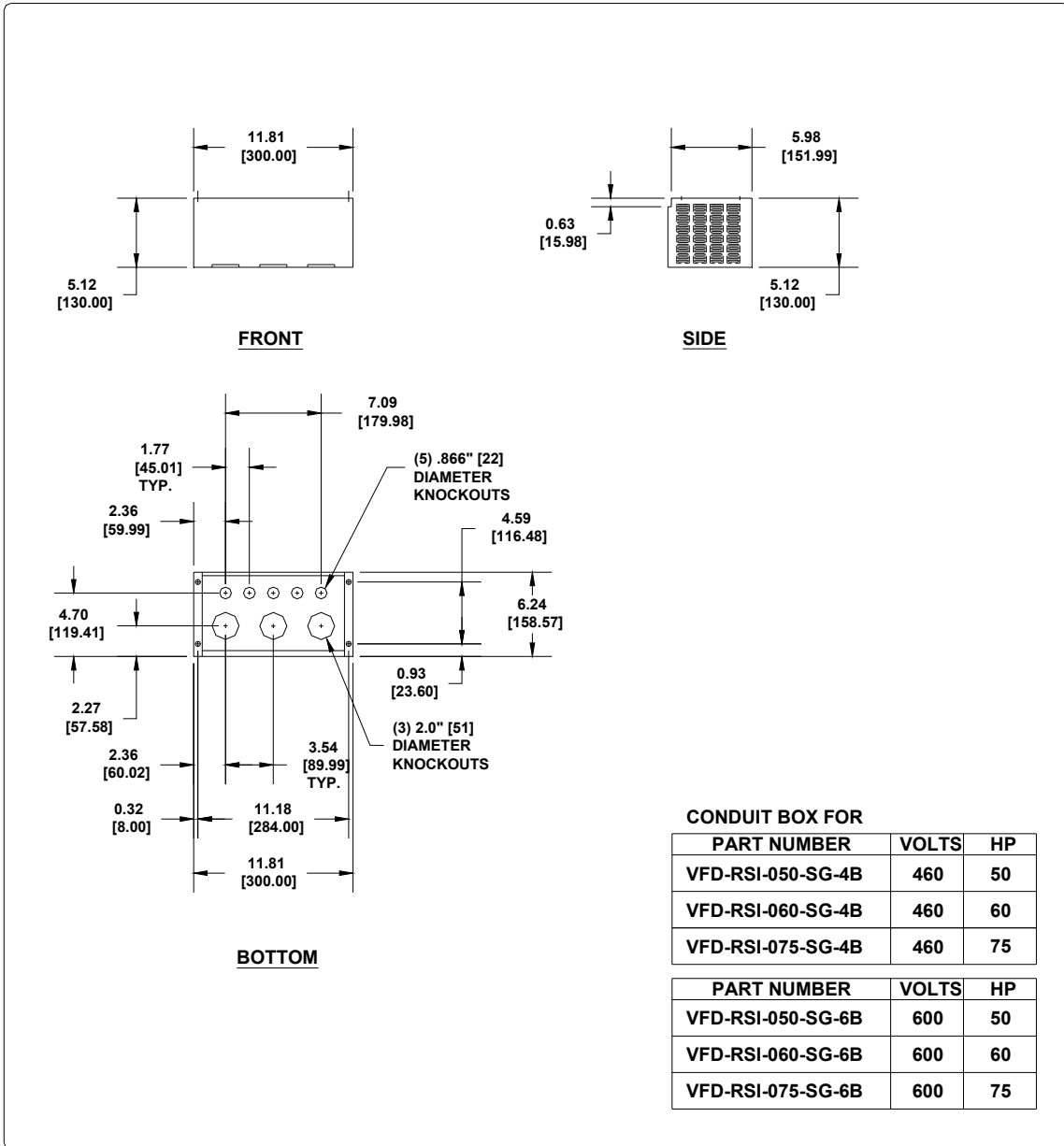
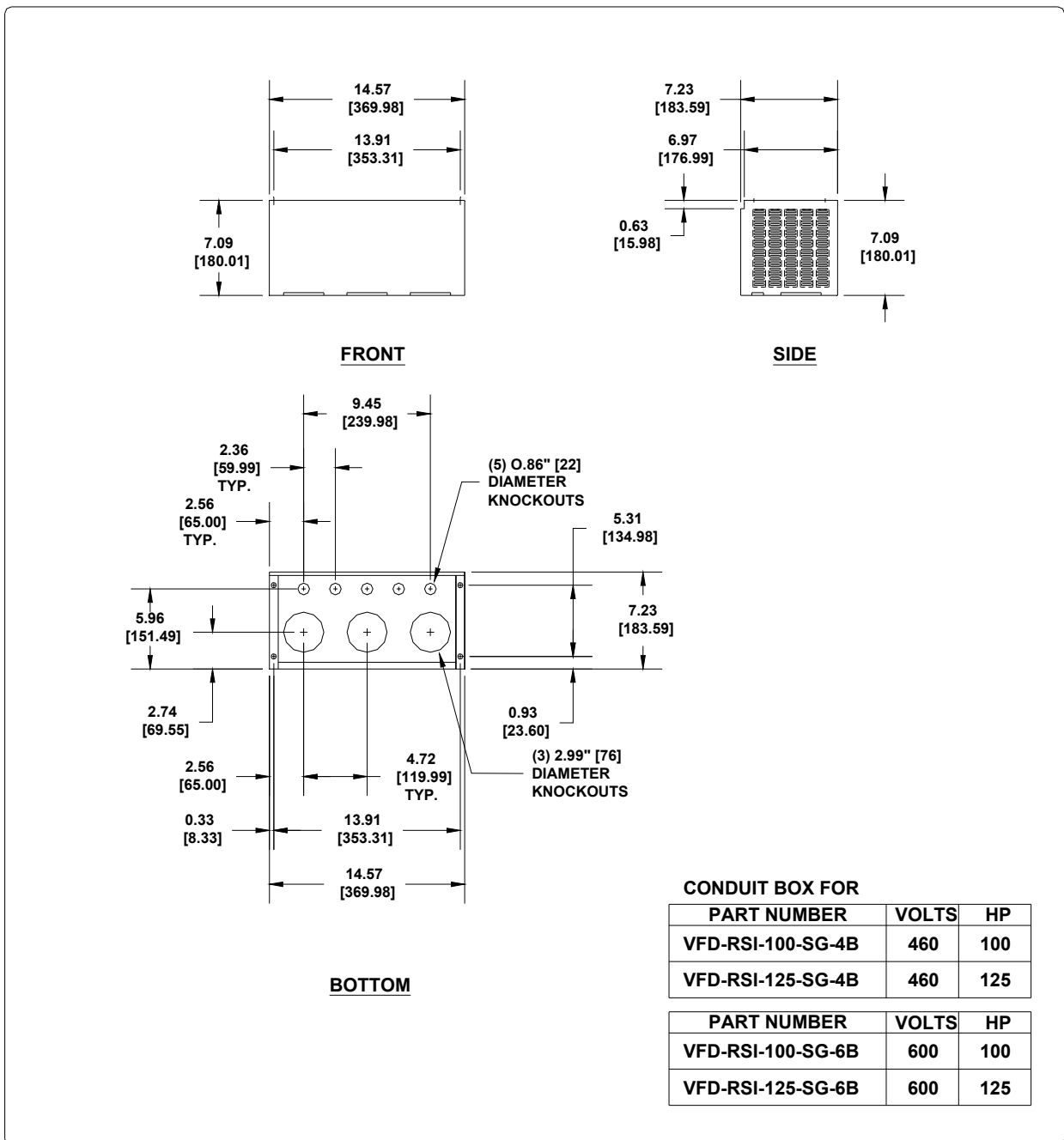

Figure C. Conduit Boxes for 100 HP ~ 125 HP



**Note:** Choose the proper size of the Locknut and Bushing corresponding to the size of the conduit used.

---

■ Notes :

## Chapter 9. RS485/MODBUS-RTU Communication

### 9.1 Introduction

The SG drive can be controlled and monitored by the sequence program of the PLC or other master module. Drives or other slave devices may be connected in a multi-drop fashion on the Modbus-RTU network and may be monitored or controlled by a single PLC or PC. Parameter settings and changes are available through a PC.

#### 9.1.1 Features

Drive can be easily applied for Factory automation because operation and monitoring is available by User-program.

- \* Parameter change and monitoring is available via computer.  
(Ex: Accel/Decel time, Freq. Command, etc.)
- \* Interface type of Modbus reference:
  - 1) Allows the drive to communicate with any other computers.
  - 2) Allows connection of up to 31 drives with multi-drop link system.
  - 3) Noise-resistant interface.

#### 9.1.2 Connection Guide for Modbus-RTU Communication with PC, PLC and RS232/485

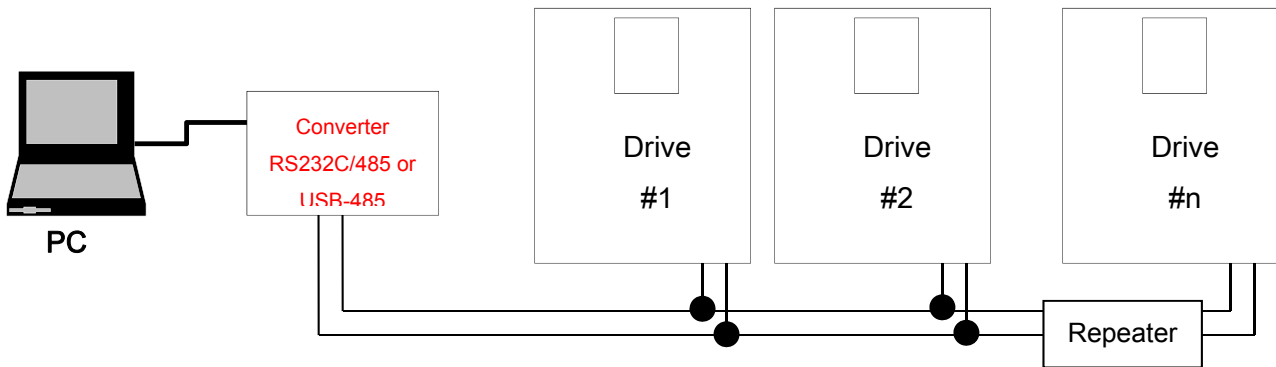

\* REPEATER is not a required item but helps communication in long-distance communication or high noise environment.

#### 9.1.3 Before Installation

Before installation and operation, this should be read thoroughly. If not, it can cause personal injury or damage to other equipment.

## 9.2 Specification

### 9.2.1 Performance Specification

Item	Specification
Transmission form	Bus method, Multi-drop Link System
Applicable inverter	SG series
Connectable drives	Max 31
Transmission distance	Max. 1,200m (Within 700m Recommended)
Recommended wire	0.75mm <sup>2</sup> (12AWG), Shield Type Twisted-Pair Wire

### 9.2.2 Hardware Specification

Item	Specification
Installation	Use C+, C-,CM terminals on control terminal block
Power supply	Use Insulated power from the inverter power supply

### 9.2.3 Communication Specification

Item	Specification
Communication speed	19,200/9,600/4,800/2,400/1,200 bps selectable
Communication system	Half duplex system
Character system	ASCII (8 bit)
Stop bit length	1 bit
Check Sum (CRC16)	2 byte
Parity bit	None
Protocol supported	Parameter Read/Write, Monitoring parameter register/execution Broadcasting

### 9.2.4 Installation

#### Connecting the communication line

- 1) Connect the Modbus-RTU communication line to the inverter's (C+), (C-) and CM terminals of the control terminals.
- 2) Connect the CM terminal among inverters for stable communication.
- 3) Check the connection and turn ON the inverter.
- 4) If the communication line is connected correctly set the communication-related parameters per the following table:
- 5) Install a repeater to upgrade the communication speed or longer than 1200mm communication line is used. Repeater is required for upgrading communication quality in the noise-high environment.



### 9.2.5 Communication Parameters

Parameter	Display	Name	Set value	Unit	Default
DRV_03	Drive mode	Drive mode	Int. 485		Fx/Rx-1
DRV_04	Freq mode	Freq mode	Int. 485		KeyPad-1
DRV_91	Drive mode2	Drive mode 2	KeyPad Fx/Rx-1 Fx/Rx-2		Fx/Rx-1
DRV_92	Freq mode2	Freq mode 2	KeyPad-1 KeyPad-2 V1 V1S I V1+I Pulse		KeyPad-1
I/O_20~27	M1 ~ M8	Programmable Digital Inputs	Loc/Rem		
I/O_90	Inv No	Inverter number	1~250		1
I/O_91	Baud rate	Communication speed	1200 bps 2400 bps 4800 bps 9600 bps 19200 bps		9600 bps
I/O_92	COM Lost Cmd	Operating mode when communication signal is lost	None FreeRun Stop		None
I/O_93	COM Time Out	Time to determine whether Communication signal is lost.	0.1~120.0	sec	1.0
I/O_94	Delay Time	Communication Response Delay Time	2 to 1000 msec	msec	5.0

## 9.3 Operation

### 9.3.1 Operating Steps

- 1) Check whether the computer and the inverter are connected correctly.
- 2) Turn ON the inverter. But, do not connect the load until stable communication between the computer and the inverter is verified. Start the operating program for the inverter from the computer.
- 3) Operate the inverter using the operating program for the inverter.
- 4) Refer to “9.6 Troubleshooting” if the communication is not operating normally.
- 5) Turn the inverter J3 switch ON to connect the terminating resistor for the end of network.

\* Connect to C+,C-,CM terminal on the control terminal. Pay attention to polarity(+, -).

\* Maximum number of connected drives is 31.

## **9.4 Communication Protocol (Modbus-RTU)**

Use Modbus-RTU protocol (Open protocol).

Computer or other hosts can be Master and Slave. The drive responds to Read/Write command from Master.

Supported function code

Function code	Description
0x03	Read Hold Register
0x04	Read Input Register
0x06	Preset Single Register
0x10	Preset Multiple Register

Exception code

Function code		Description
0x01		ILLEGAL FUNCTION
0x02		ILLEGAL DATA ADDRESS
0x03		ILLEGAL DATA VALUE
0x06		SLAVE DEVICE BUSY
User define	0x14	1. Write Disable (Address 0x0004 value is 0) 2. Read Only or Not Program during Running.

## 9.5 Parameter Code List

<Common area>: Area accessible regardless of drive model (Note 1)

Address (HEX)	Parameter Name	Unit	Read/Write	Data Value (Hex)
0x0000	Drive model	-	R	4: RSi-SG-XXX
0x0001	Drive capacity	-	R	4: 5.5 5: 7.5 6: 11 7: 15 8: 18.5 9: 22 A: 30 B: 37 C: 45 D: 55 E: 75 F: 90 10: 110 11: 132 12: 160 13: 200 14: 220 15: 280 16: 375 17: 450 (Unit : kW)
0x0002	Drive Input Voltage	-	R	0: 220V 1: 460V 2: 575V
0x0003	S/W Version	-	R	0100: Ver. 1.0, 0101: Ver. 1.1, 0004: Ver.0.4
0x0005	Frequency Reference	0.01Hz	R/W	
0x0006	Run Command (Bits 0 – 2)	-	R/W	BIT 0: Stop (S)
				BIT 1: Forward run (F)
				BIT 2: Reverse run (R)
				BIT 3: Fault reset (0->1)
				BIT 4: Emergency Stop
	Start/Stop (Bits 6, 7)		BIT 5: Not used	
			BIT 6, BIT 7: Run/Stop command source	
			0:Terminal 1:Keypad 2:Comm.Opt. 3: Int. 485	
			BIT 8 ~14: Freq. Reference	
			0 ~ 16: Multi-step speed freq. (0, 2~16)	
Frequency Reference (Bits 8 ~ 14) Values 0 ~ 29 are decimal values	17 ~ 19: Up/Down (Up, Down, UD Zero)			
	20 ~ 25: Analog			
	20:V1 21: V1S 22: I 23:NA 24:V1+I			
	25:Pulse 26:Int.485 27:Jog 28:Ext.PID			
	29: Comm.Opt.Bd.			
	BIT 15: set when Network error			
0x0007	Acceleration Time	0.1 sec	R/W	
0x0008	Deceleration Time	0.1 sec	R/W	
0x0009	Output Current	0.1 A	R	
0x000A	Output Frequency	0.01 Hz	R	
0x000B	Output Voltage	V	R	
0x000C	DC Link Voltage	0.1 V	R	
0x000D	Output Power	0.1 kW	R	
0x000E	Operating Status	-	R	BIT 0: Stop BIT 1: Forward Run BIT 2: Reverse Run BIT 3: Fault (Trip) BIT 4: Accelerating BIT 5: Decelerating BIT 6: Output Frequency Arrival BIT 7: DC Braking BIT 8: Stopping BIT 9: Not Used BIT 10: BrakeOpen BIT 11: Forward Run Command BIT 12: Reverse Run Command BIT 13: Start/Stop via Int. 485 (or Opt. Bd.) BIT 14: Freq. Ref via Int. 485 (or Opt Bd.)

## Chapter 9 – RS485/Modbus RTU Communications

Address (HEX)	Parameter Name	Unit	Read/Write	Data Value (Hex)
0x000F	Trip information	-	R	<b>BIT 0:</b> OCT1 (Over Current-1) <b>BIT 1:</b> OV (Over Voltage) <b>BIT 2:</b> EXT-A (Ext Trip) <b>BIT 3:</b> BX (E-Stop) <b>BIT 4:</b> LV (Low Voltage) <b>BIT 5:</b> Not Used <b>BIT 6:</b> GF (Ground Fault) <b>BIT 7:</b> IOHT (Inverter Overheat) <b>BIT 8:</b> ETH (Motor Overheat) <b>BIT 9:</b> OLT (Overload Trip) <b>BIT 10:</b> HW-diag <b>BIT 11:</b> Not Used <b>BIT 12:</b> OCT2 (Over Current-2) <b>BIT 13:</b> OPT Error <b>BIT 14:</b> PO (Phase Open) <b>BIT 15:</b> IOLT (Inverter Overload Trip)
0x0010	Input Terminal Status	-	R	<b>BIT 0:</b> M1 <b>BIT 1:</b> M2 <b>BIT 2:</b> M3 <b>BIT 3:</b> M4 <b>BIT 4:</b> M5 <b>BIT 5:</b> M6 <b>BIT 6:</b> M7 <b>BIT 7:</b> M8
0x0011	Output Terminal Status	-	R	<b>BIT 0:</b> AUX1 <b>BIT 1:</b> AUX2 <b>BIT 2:</b> AUX3 <b>BIT 3:</b> AUX4 <b>BIT 4, 5, 6:</b> Not Used <b>BIT 7:</b> 3A – 3C
0x0012	V1	0 – 10V	R	0 – FFC0
0x0013	V1S	0 – 10V	R	0 – FFC0
0x0014	I	0 – 20mA	R	0 – FFC0
0x0015	RPM	-	R	

**9.5.1 Common area address 0x0006**

Detail description on Common area address 0x0006 (Note 1)

Bit	Value	R/W	Name	Description
0	0x01	R/W	Stop	Issue a Stop command (0->1)
1	0x02	R/W	Forward run	Issue a Forward run command via communication (0->1)
2	0x04	R/W	Reverse run	Issue a Reverse run command via communication (0->1)
3	0x08	R/W	Fault reset	Issue a Fault reset command via communication (0->1)
4	0x10	R/W	Emergency stop	Issue a Emergency stop command via communication (0->1)
5			Not used	Not Used
6~7		R	Operating command	0(Terminal),1(keypad),2(option),3(Int. 485)
8~14		R	Frequency command	A. When operating command is issued via Terminal, Keypad or Option 0 : DRV-00,                      1 : Not used, 2 : Multi-step speed 1,        3 : Multi-step speed 2, 4 : Multi-step speed 3        5 : Multi-step speed 4, 6 : Multi-step speed 5        7 : Multi-step speed 6, 8 : Multi-step speed 7        9 : Multi-step speed 8, 10 : Multi-step speed 9       11 : Multi-step speed 10, 12 : Multi-step speed 11,    13 : Multi-step speed 12, 14 : Multi-step speed 13,    15 : Multi-step speed 14, 16 : Multi-step speed 15, 17 :Up,                            18 : Down, 19 : Up/Down Zero 20~21 : RESERVE 22 : V1,    23 : V1S,    24 : I,    25 : V1+I 26 : Pulse 27 : Sub 28 : Int. 485 29 : Option 30 : Jog 31 : PID
15	0x8000	R	Network error	Network malfunction

**Note 1:** When you modify data through the common parameters, the data is not saved. The modified data is applied only at the present time. The data will revert to the previous value when the inverter is reset or its power is cycled Off/On again. When you modify data through the group parameters except the common, the modified value can be saved by changing COM-67 to “yes”. The modified value is also saved when the inverter is reset or its power is cycled Off/On.

9.5.2 SG operating status in Address E, Common area

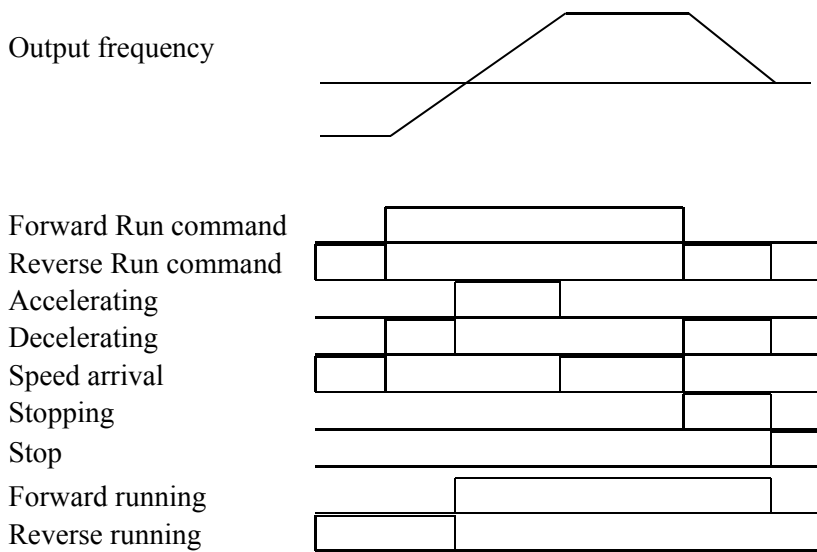

< Address usage area by groups >

DRV	9100 - 91FF
FUN	9200 - 92FF
AFN	9300 - 93FF
I/O	9400 - 94FF
EXT	9500 - 95FF
COM	9600 - 96FF
APP	9700 - 97FF

Address setting method to access the parameter using Modbus: area assigned by inverter+ Address usage area by groups + Code no. (Hex).

Ex) To check the content of I/O-93 [COM Time Out]; perform Read or Write of address 0x945D.

## 9.6 Troubleshooting

Refer to the below chart when Modbus-RTU communication error occurs.

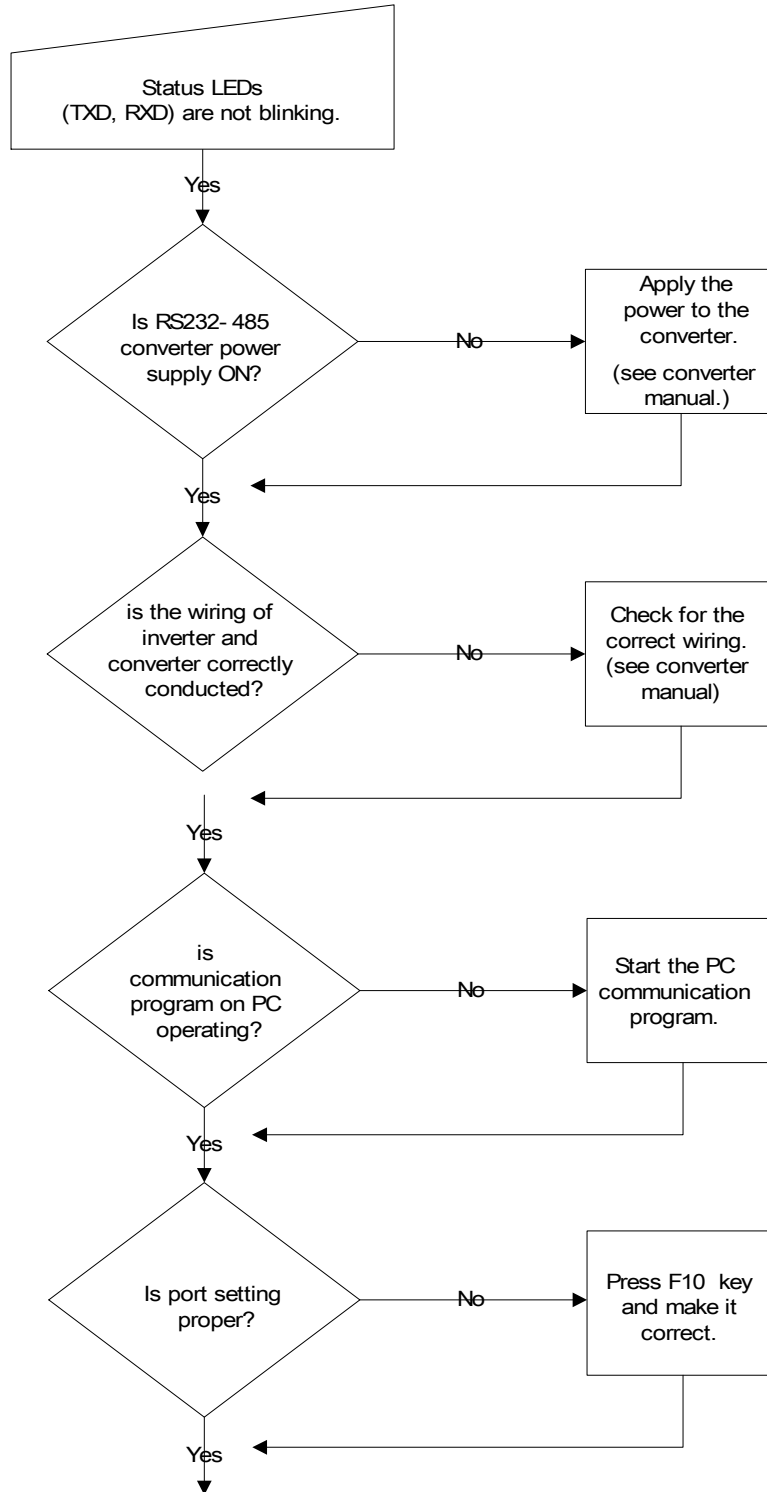

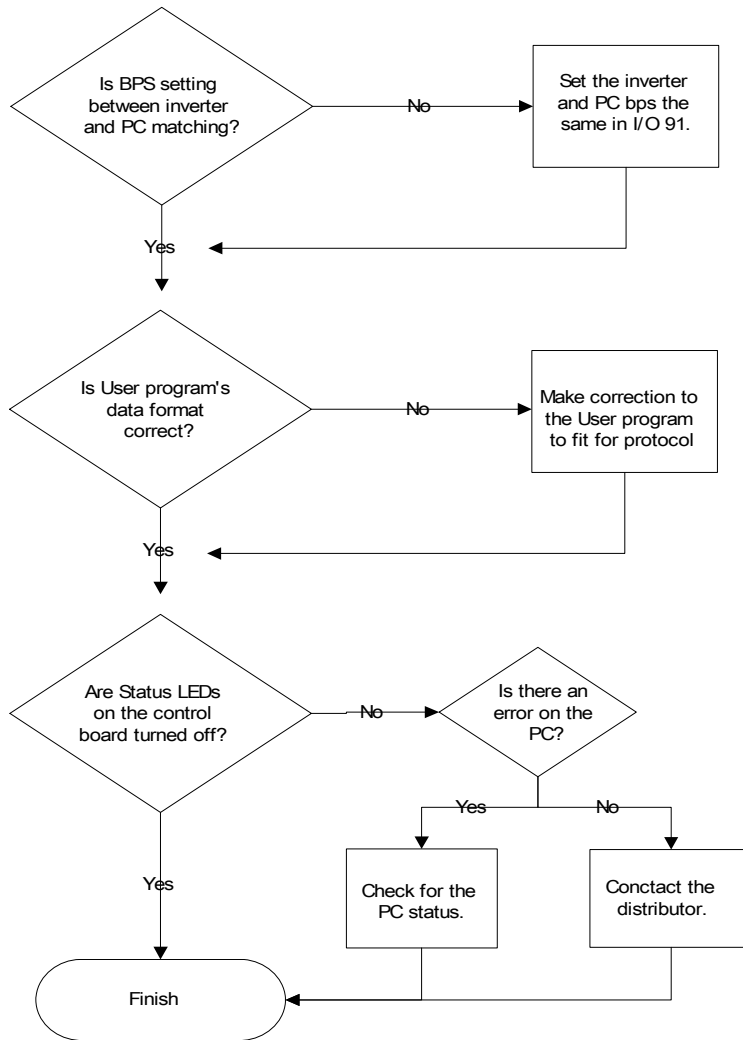



# **APPENDIX A- UL Marking**

## 1. Short Circuit Rating

Suitable for use on a circuit capable of delivering not more than 100,000 A(rms) Symmetrical amperes when protected by a breaker or fuse with an interrupt rating of not less than 100,000 A(rms).

Maximum Voltage

240V for 240V rated drives, 480V for 480V rated drives, 600V for 600V rated drives.”

Table 1. RMS Symmetrical Amperes for SG series drive.

Drive Model	Rating
RSi007SG-2B, RSi007SG-4B, RSi007SG-6B, RSi010SG-2B, RSi010SG-4B, RSi010SG-6B, RSi015SG-2B, RSi015SG-4B, RSi015SG-6B, RSi020SG-2B, RSi020SG-4B, RSi020SG-6B, RSi025SG-2B, RSi025SG-4B, RSi025SG-6B, RSi030SG-2B, RSi030SG-4B, RSi030SG-6B, RSi040SG-2B, RSi040SG-4B, RSi040SG-6B, RSi050SG-4B, RSi050SG-6B, RSi060SG-4B, RSi060SG-6B, RSi075SG-4B, RSi075SG-6B, RSi100SG-4B, RSi100SG-6B, RSi125SG-4B, RSi125SG-6B, RSi150SG-4, RSi150SG-6, RSi200SG-4, RSi250SG-4, RSi350SG-4, RSi400SG-4, RSi500SG-4, RSi600SG-4, RSi700SG-4	100,000A

## 2. Short Circuit Fuse/Breaker

UL Listed Semiconductor Input Fuses or a UL Listed Breaker Only. See the table below for the required Voltage and Current rating of the fuses and breakers.

Input Voltage	Model Number RSi-xxx-SG	External Input Fuse		External Breaker	
		Current [A]	Voltage [V]	Current [A]	Voltage [V]
230V Class	007SG-2B	40	500	30	230
	010SG-2B	60	500	40	230
	015SG-2B	80	500	60	230
	020SG-2B	100	500	80	230
	025SG-2B	125	500	100	230
	030SG-2B	150	500	125	230
	040SG-2B	200	500	150	230
460V Class	007SG-4B	20	500	15	460
	010SG-4B	30	500	20	460
	015SG-4B	40	500	30	460
	020SG-4B	60	500	40	460
	025SG-4B	70	500	50	460
	030SG-4B	80	500	60	460
	040SG-4B	100	500	80	460

## Appendix A – UL Marking

Input Voltage	Model Number RSi-xxx-SG	External Input Fuse		External Breaker	
		Current [A]	Voltage [V]	Current [A]	Voltage [V]
460V Class	050SG-4B	125	500	100	460
	060SG-4B	150	500	125	460
	075SG-4B	175	500	150	460
	100SG-4B	250	500	200	460
	125SG-4B	300	500	250	460
	150SG-4	350	700	300	460
	200SG-4	400	700	350	460
	250SG-4	450	700	450	460
	350SG-4	700	700	600	460
	400SG-4	800	700	700	460
	500SG-4*	800	700	1000	460
	600SG-4*	900	700	1200	460
	700SG-4*	1000	700	1200	460
600V Class	007SG-6B	16	600	20	600
	010SG-6B	20	600	20	600
	015SG-6B	30	600	25	600
	020SG-6B	40	600	30	600
	025SG-6B	50	600	40	600
	030SG-6B	60	600	50	600
	040SG-6B	80	600	60	600
	050SG-6B	100	600	80	600
	060SG-6B	125	600	80	600
	075SG-6B	150	600	100	600
	100SG-6B	175	600	150	600
	125SG-6B	250	600	200	600
	150SG-6	300	600	200	600
	200SG-6	350	600	250	600
	250SG-6	450	600	350	600
350SG-6	600	600	500	600	
400SG-6	700	600	600	600	

- \*Internal Line fusing provided with these models.

## APPENDIX B- Related Parameters

Use	Related parameters
Accel/Decel time, Pattern Adjustment	DRV-01 [Acceleration Time], DRV-02 [Deceleration Time], FUN-02 [Acceleration Pattern], FUN-03 [Deceleration Pattern]
Reverse Rotation Prevention	FUN-01 [Forward/Reverse Prevention]
Accel/Decel at Continuous Rating Range	FUN-02 [Acceleration Pattern], FUN-03 [Deceleration Pattern]
Braking Operation Adjustment	FUN-20 [Starting Mode], FUN-21~22 [DC Injection Braking at Starting] FUN-23 [Stop Mode], FUN-24~27 [DC Injection Braking],
Operations at freq. Over 60 Hz	FUN-30 [Max. Frequency], FUN-35 [Frequency High Limit], I/O-05 [Frequency Corresponding to V1 Max Voltage], I/O-10 [Frequency Corresponding to I Max Current], I/O-16 [Frequency Corresponding to P Max Pulse Frequency]
Selecting an Appropriate Output Characteristics for the Load	FUN-30 [Max. Frequency], FUN-31 [Base Frequency]
Motor Output Torque Adjustment	FUN-32 [Starting Frequency], FUN-70~71 [Stall Prevention], AFN-67~69 [Torque Boost], AFN-40 [Motor Rating]
Output Frequency Limit	FUN-33~35 [Frequency High/Low Limit], I/O-01~16 [Analog Frequency Setting]
Motor Overheat Protection	DRV-06~09 [Electronic Thermal], AFN-40 [Motor Rating] I/O-97, 98 [External Thermal Sensor], DRV-05 [Motor Rated Current]
Multi-step Operation	I/O-20~27 [Multi-function Input Define], DRV-00, 05~07, I/O-31~42 [Multi-step Frequency], FUN-34~35 [Frequency High/Low Limit]
Jog Operation	I/O-30 [Jog Frequency]
Frequency Jump Operation	AFN-10~16 [Frequency Jump]
Electronic Brake Operation Timing	I/O-74~75 [Frequency Detection], I/O-76~79 [Multi-function Output]
Rotating Speed Display	DRV-14 [Motor Rpm], AFN-47 [Motor Rpm Display Gain]
Function Change Prevention	AFN-94 [Parameter Lock]
Energy Saving	FUN-51~52 [Energy Saving]
Auto Restart Operation after Alarm Stop	AFN-20~21 [Auto Restart]
2 <sup>nd</sup> Motor Operation	APP-20~29 [2 <sup>nd</sup> Function]
PID Feedback Operation	APP-02~33 [PID Operation]
Adjusting Frequency Reference/Output	I/O-01~16 [Analog Frequency Setting]
Defining Multi-function Input terminals	I/O-20~27 [Multi-function Input Terminal]
Defining Multi-function Output terminals	I/O-76~79 [Multi-function Output Terminal]
Commercial Line<-> Inverter Switchover	I/O-20~27 [Multi-function Input Terminal], I/O-76~79 [Multi-function Output Terminal]
Frequency Meter Calibration	I/O-70~73 [S0/S1 Analog Output]
Operation via Communication with a PC	I/O-90 [Inverter Number], I/O-91 [Communication Speed], I/O-92~93 [Lost Command]



# **APPENDIX C - DECLARATION OF CONFORMITY**

Council Directive(s) to which conformity is declared:

**CD 73/23/EEC and CD 89/336/EEC**

Units are certified for compliance with:

**EN 61800-3/A11 (2000), EN 61000-4-2/A2 (2001), EN 61000-4-3/A2 (2001), EN 61000-4-4/A2 (2001), EN 61000-4-5/A1 (2001), EN 61000-4-6/A1 (2001), EN 55011/A2 (2002), EN 50178 (1997), IEC/TR 61000-2-1 (1990), EN 61000-2-4 (1994), EN 60146-1-1/A1 (1997)**

Product Category: **Motor Controller**

Type of Equipment: **Adjustable Speed Drive**

Model Name: **RSi - SG Series**

Manufacturer Name: **Benshaw, Inc.**

Manufacturers Address: **615 Alpha Drive  
Pittsburgh, PA USA  
15238**

**The products referenced above are used to control the speed of AC motors. For application information, consult the following documentation from Benshaw: Publication number 890046-00-xx.**

**The use in residential and commercial premises (Class B) requires an optional RFI/EMI filter. Via internal mechanisms and Quality Control, it is verified that these products conform to the requirements of the Directive and applicable standards.**

**We, the undersigned, hereby declare that equipment specified above conforms to the Directives and Standards mentioned.**

Glenshaw, PA USA – 29 October 2004

Neil Abrams  
Quality Control  
Manager

Harry Hagerty  
VP General Manager

## Appendix C – Declaration of Conformity

---

### TECHNICAL STANDARDS APPLIED

The standards applied in order to comply with the essential requirements of the Directives 73/23/CEE "Electrical material intended to be used with certain limits of voltage" and 89/336/CEE "Electromagnetic Compatibility" are the following ones:

• EN 50178 (1997)	“Electronic equipment for use in power installations”.
• EN 61800-3/A11 (2000)	“Adjustable speed electrical power drive systems. Part 3: EMC product standard including specific methods”
• EN 55011/A2 (2002)	“Industrial, scientific and medical (ISM) radio-frequency equipment. Radio disturbances characteristics. Limits and methods of measurement”
• EN 61000-4-2/A2 (2001)	“Electromagnetic compatibility (EMC). Part 4: Testing and measurement techniques. Section 2: Electrostatic discharge immunity test.
• EN 61000-4-3/A2 (2001)	“Electromagnetic compatibility (EMC). Part 4: Testing and measurement techniques. Section 3: Radiated, radiofrequency, electromagnetic field immunity test.
• EN 61000-4-4/A2 (2001)	“Electromagnetic compatibility (EMC). Part 4: Testing and measurement techniques. Section 4: Electrical fast transients / burst immunity test.
• EN 61000-4-5/A1 (2000)	“Electromagnetic compatibility (EMC). Part 4: Testing and measurement techniques. Section 5: Surge immunity test.
• EN 61000-4-6/A1 (2001)	“Electromagnetic compatibility (EMC). Part 4: Testing and measurement techniques. Section 6: Immunity to conducted disturbances, induced by radio-frequency fields.
• CEI/TR 61000-2-1 (1990)	“Electromagnetic compatibility (EMC). Part 2: Environment. Environment description for low-frequency conducted disturbances and signalling in public low voltages supply systems”
• EN 61000-2-4 (1997)	“Electromagnetic compatibility (EMC). Part 2: Environment. Compatibility level in industrial plants for low-frequency conducted disturbances”
• EN 60146-1-1/A1 (1997)	“Semiconductor converters. General requirements and line commutated converters. Part 1-1: Specifications of basic requirements”

## **EMI / RFI POWERLINE FILTERS**

### **RFI FILTERS**

THE USE OF EMI/RFI FILTERS HELPS TO ENSURE TROUBLE FREE OPERATION ALONGSIDE SENSITIVE DEVICES AND COMPLIANCE TO CONDUCTED EMISSION AND IMMUNITY STANDARDS **EN 50081 -> EN61000-6-3:02 and EN61000-6-1:02**. CONTACT BENSCHAW, INC. FOR MORE INFORMATION.

### **NOTE**

IN THE CASE WHERE A LEAKAGE CURRENT PROTECTIVE DEVICE IS USED ON THE INCOMING POWER SUPPLY, IT MAY TRIP AT POWER-ON OR POWER-OFF DUE TO THE ADDITION OF THE POWER LINE FILTER. IN ORDER TO AVOID THIS, THE SENSE CURRENT OF PROTECTIVE DEVICE SHOULD BE SET HIGHER THAN VALUE OF LEAKAGE CURRENT SEEN DURING POWER UP OR POWER DOWN.

### ***RECOMMENDED FILTER INSTALLATION INSTRUCTIONS***

**To conform to the EMC directive, it is necessary that these instructions be followed as closely as possible. Follow the usual safety procedures when working with electrical equipment. A qualified electrical technician must make all electrical connections to the filter, drive and motor.**

- 1) Check the filter rating label to ensure that the current, voltage rating and part number are correct.
- 2) For best results, the filter should be fitted as closely as possible to the incoming mains supply of the wiring enclosure, usually directly after the enclosure's circuit breaker or supply switch.
- 3) The back panel of the wiring cabinet of board should be prepared for the mounting dimensions of the filter. Care should be taken to remove any paint etc. from the mounting holes and face area of the panel to ensure the best possible grounding of the filter.
- 4) Mount the filter securely.
- 5) Connect the mains supply to the filter terminals marked LINE; connect any earth cables to the earth stud provided. Connect the filter terminals marked LOAD to the mains input of the drive using short lengths of appropriate gauge cable.
- 6) Connect the motor and fit the ferrite cores (output chokes) as close to the drive as possible. Armoured or shielded cable should be used with the 3 phase conductors only threaded twice through the center of the ferrite core. The earth conductor should be securely grounded at both the drive and motor ends. The screen should be connected to the enclosure body via a ground cable gland.
- 7) Connect any control cables as instructed in the drive instruction manual.

NOTE: IT IS IMPORTANT THAT ALL LEAD LENGTHS ARE KEPT AS SHORT AS POSSIBLE AND THAT INCOMING POWER AND OUTGOING MOTOR CABLES ARE KEPT WELL SEPARATED.







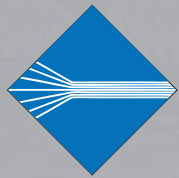

**BENSHAW**  
ADVANCED CONTROLS & DRIVES

BENSHAW  
615 Alpha Drive  
Pittsburgh, PA 15238  
Phone: (412) 968-0100  
Fax: (412) 968-5415

BENSHAW Canada  
550 Bright Street  
Listowel, Ontario N4W 3W3  
Phone: (519) 291-5112  
Fax: (519) 291-2595